

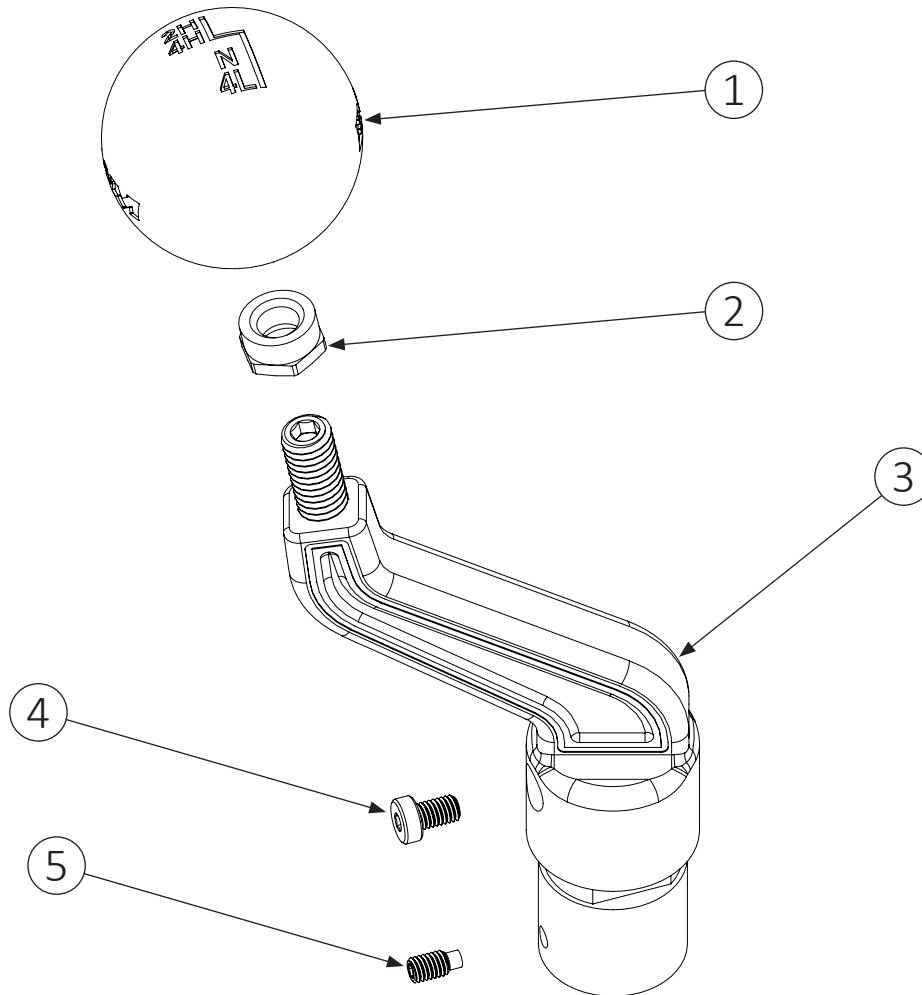

Installation Instructions
81173
 2018-22 JEEP WRANGLER &
 2020-22 JEEP GLADIATOR,
 2.0L & 3.6L ENGINE;
 2021-22 JEEP WRANGLER 6.4L ENG.



ITEM NO.	PART NO.	DESCRIPTION	QTY.
1	4101388	SHIFT KNOB, TRANSFER CASE, RED LOGO	1
2	1794720	JAM NUT, 3/8-16 UNC, SHIFT KNOB, BLACK	1
3	N/A, PRE-ASSEMBLED	SHIFT HANDLE ASSY, TRANSFER CASE	1
N/A	• 4101379	• STICK	1
	• 97003171	• SCREW, CUP POINT SET, 3/8-16 × 1.5" L, BLACK OXIDE	1
4	3401600	CAP SCREW, M5-0.8 × 8MM L, LOW PROFILE	1
5	3401601	SET SCREW, 10-32 × 3/8" L, EXTENDED TIP, EXTRA LONG	1
NOT SHOWN	3401604	CABLE TIE, BLACK NYLON, 6", 10-LB BREAK STRENGTH	1

REQUIRED TOOLS AND MATERIALS

- Medium strength thread locking fluid (Permatex Blue or equivalent)
- Slim-profile 9/16" open-end wrench

REVIEW THESE INSTRUCTIONS AND VERIFY THE KIT CONTENTS

1. Take a moment to read and understand these instructions before installing your B&M transfer case shift handle.
2. Use the parts drawing and list (front page) to verify your kit's contents. In the unlikely event that any parts are missing, please contact B&M Technical Support for replacements.

REMOVE THE STOCK SHIFT HANDLE

NOTE: Retain all factory parts.

3. To prevent the vehicle from rolling when the shifters are manipulated, set the parking brake. Shift the transmission into 5th or 6th gear, to have the most room to work.



4. Feel through the leather boot to locate the boot frame. Carefully lift up on the inside of the frame, working your way around, to separate it from the center console.



5. Pull the boot frame up over the shift knob, until the boot clears the screw in the plastic collar.



6. Remove the set screw from the driver side of the plastic collar.



7. Lift the shift knob and boot off of the shift lever.



8. Pull the boot back down over the plastic collar. Firmly grasp both the shift knob and collar, and pull them apart.



9. The leather boot is glued to the plastic collar. Detach the boot from the collar. **NOTE: Work carefully to avoid tearing the boot.**

INSTALL YOUR B&M SHIFTER HANDLE

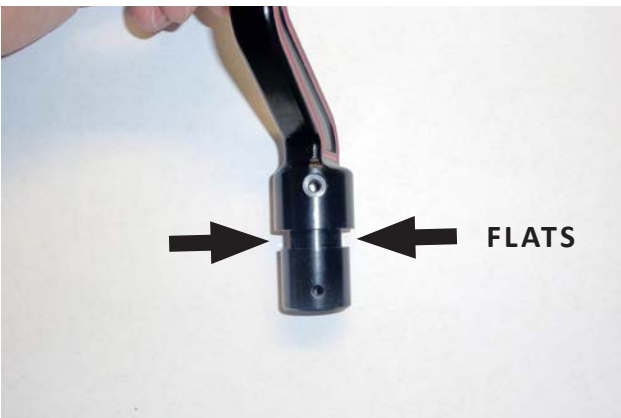

10. On the shift handle (3), note the two flats on the cable tie groove.



11. On the shift boot, note that the frame is taller on the driver side than on the passenger side. Insert the shift handle into the boot with the knob screw oriented toward the driver side.



12. Carefully work the boot opening over the end of the shift handle until the narrow section of the boot (where it was glued to the plastic collar) is situated over the cable tie groove.



13. Install the supplied cable tie over the boot. Before tightening it, adjust the boot so that it is evenly distributed around the shift handle. Then tighten the cable tie, with its buckle situated against the front flat.



14. Trim the tail off the cable tie.



17. Pull the shift boot down and snap the boot frame into the center console.



15. Install the shift handle and boot over the shift lever.

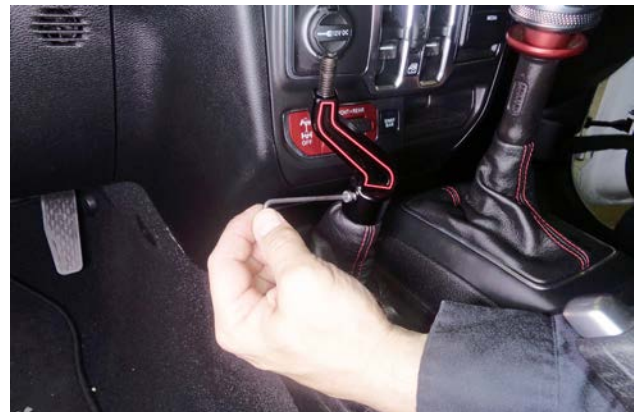

18. Apply medium strength thread locking fluid to cap screw (4) and install it in the shift handle.

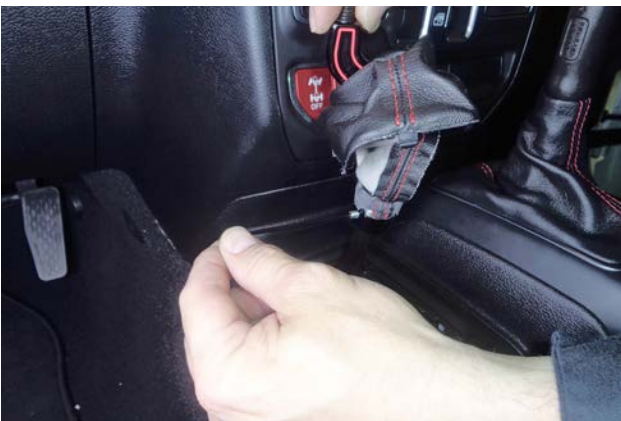

16. Apply medium strength thread locking fluid to set screw (5) and install it in the shift handle.



19. Run the jam nut (2) all the way down the knob screw, with the wrench flats facing down.

**IMPORTANT: RETAIN THESE INSTRUCTIONS
FOR FUTURE REFERENCE**



20. Thread the shift knob (1) all the way down the screw, then back it off just enough to give the desired shift pattern alignment. Use a slim-profile 9/16" wrench to tighten the jam nut against the knob.



**Congratulations, the installation of your B&M
Transfer Case Shift Handle is now complete!**

