

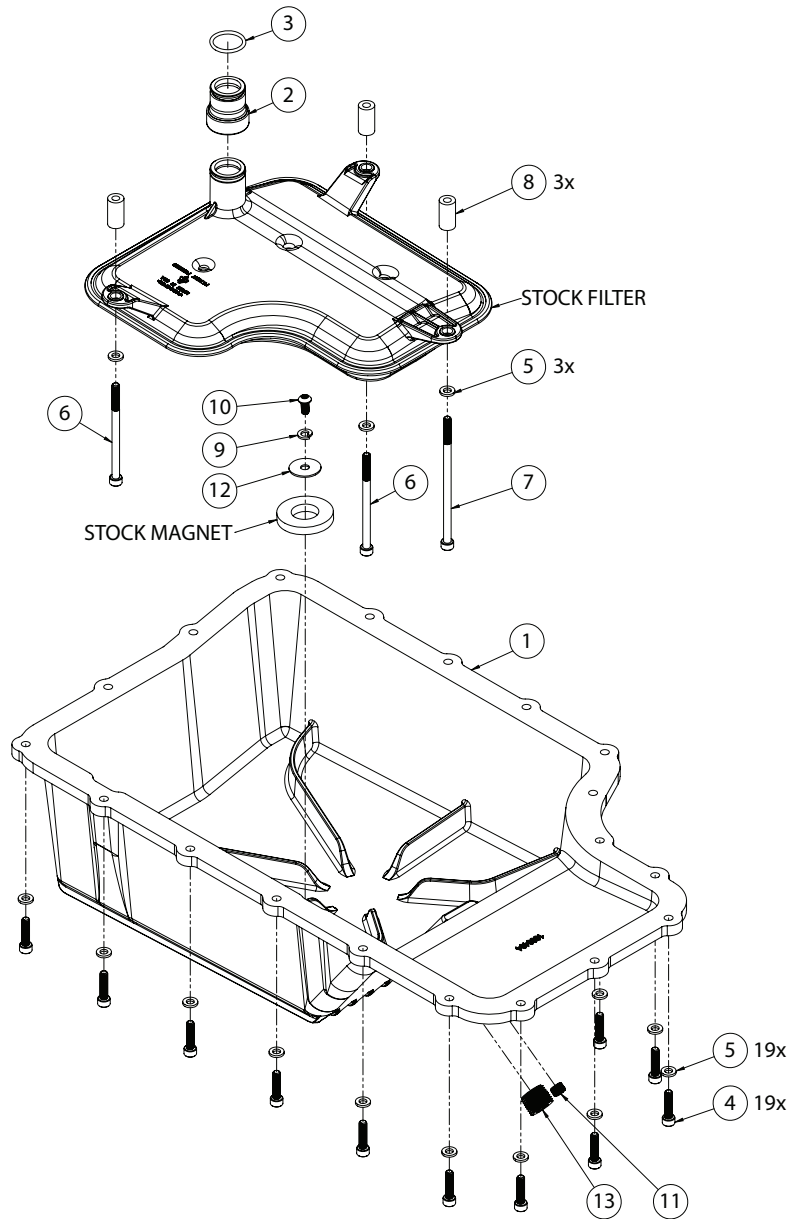

Installation Instructions  
**70397 & 71397**  
**DEEP CAST TRANSMISSION PAN**  
**2011-19 FORD**  
 6R140 Transmissions



ITM #	PART #	DESCRIPTION	QTY.
1	1000495/499	Cast Pan	1
2	1400479	Extension	1
3	3401659	O-Ring	1
4	3401664	M6-1 X 25MM Screw	19
5	3401665	6.4MM ID X 12MM Washer	22
6	3401666	M6-1 X 90MM Screw	2

ITM #	PART #	DESCRIPTION	QTY.
7	3401667	M6-1 X 120MM Screw	1
8	3401668	13MM OD X 25MM Spacer	3
9	3401195	M6 Lock Washer	1
10	3401369	M6 X 12MM Screw	1
11	3401485	1/8 Dryseal Plug	1
12	3401488	1/4 Oversized Flat Washer	1
13	3401492	1/2 NPTF Hex Socket Plug	1

## OVERVIEW:

Thank you for purchasing B&M Transmission Pan. This kit is designed to work on 6R140 transmissions. Be sure to acquire the factory fill procedure, which varies between specific models, prior to beginning project.

B&M also offers the following related products:

**Temperature Gauge (80212):** Add a gauge to monitor your transmission fluid temperature.



1. Please take a moment to read and understand these instructions before installing your purchased performance kit. Use the parts drawing and list to verify kit contents.

## REMOVE FACTORY TRANSMISSION PAN:

### WARNINGS:

- Automatic transmissions operate at temperatures between 150° and 250°. To avoid burns from hot oil and parts, allow vehicle to cool off for a few hours before beginning installation.
- Maintain clean working surface as transmission components are precision fit so any dirt will directly impact success of installation.
- Vehicle must be level for stability and to obtain an accurate fluid level.

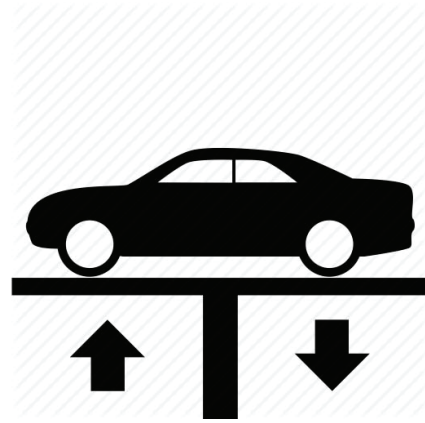

2. Raise vehicle up on a hoist or rack to working height. If you don't have access to a hoist or rack, raise vehicle and support securely with jack stands. Verify your vehicle will not move as you complete installation of your performance product.



3. If possible, remove drain plug (your vehicle may not have a plug) and empty transmission fluid.

**NOTE:** Draining fluid through plug opening will only partially drain transmission pan.



**NOTE:** Remove bolts starting from front of pan then moving laterally towards back to direct remaining fluid into drain pan.

4. Remove bolts (x19) securing transmission pan to case, then carefully remove pan from vehicle.

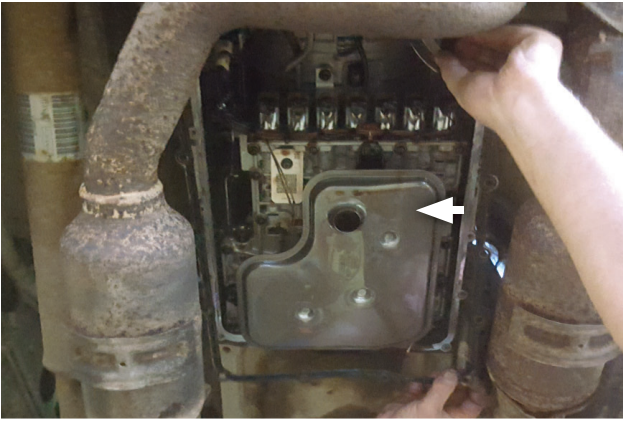

5. Remove and inspect transmission pan gasket. If it is still serviceable, clean and retain it, then wipe mounting surface.

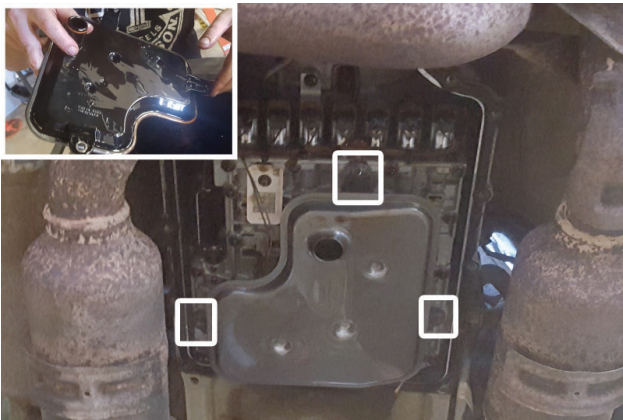

6. Remove (x3) bolts then pull transmission pan filter down and off of vehicle.



7. Remove and retain magnet from factory transmission pan.

## ASSEMBLE AND INSTALL B&M PERFORMANCE TRANSMISSION PAN:

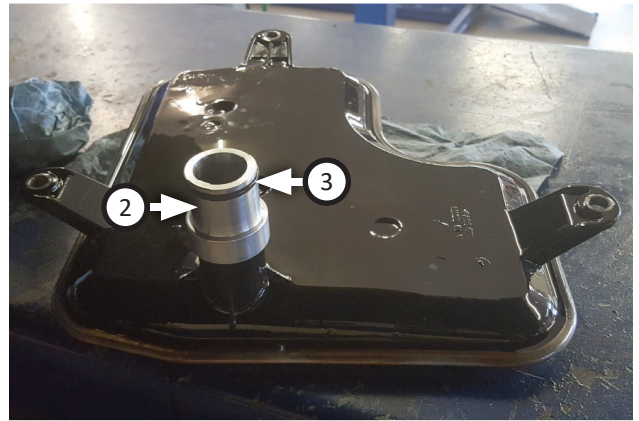

8. Fit o-ring (3) into groove on extension (2) then install onto transmission filter.

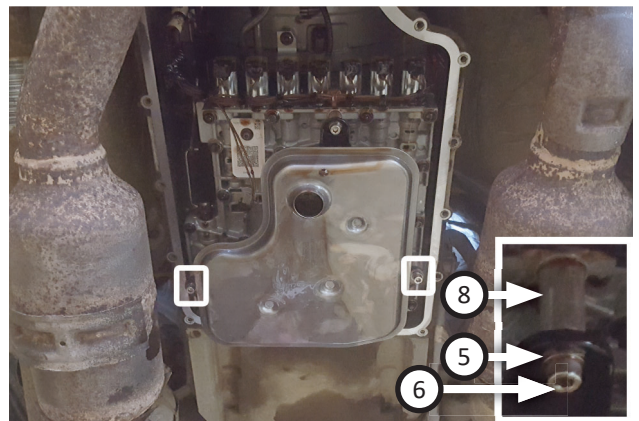

9. Fasten stock filter to transmission by installing (x2 ea.) screws (6) through washers (5), stock filter and spacers (8).

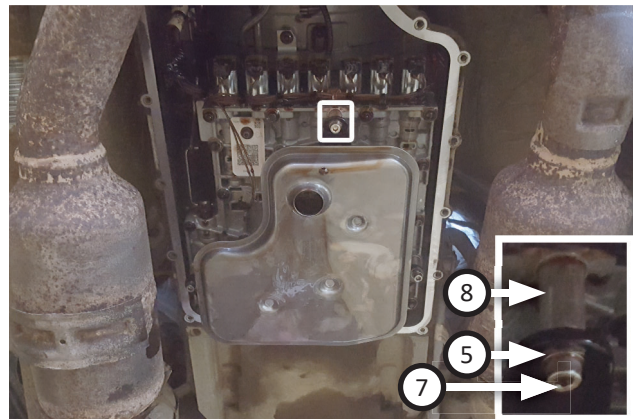

10. Fasten stock filter to transmission by installing screw (7) through washer (5), stock filter and spacer (8).



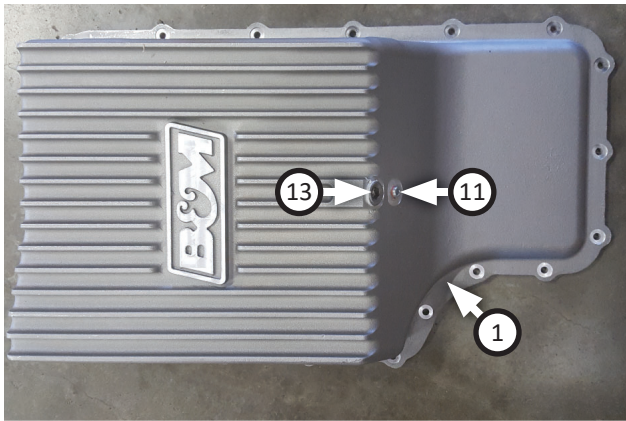

11. Apply sealant tape to **socket plug (13)**. Install **socket plugs (11) & (13)** into **cast pan (1)**.

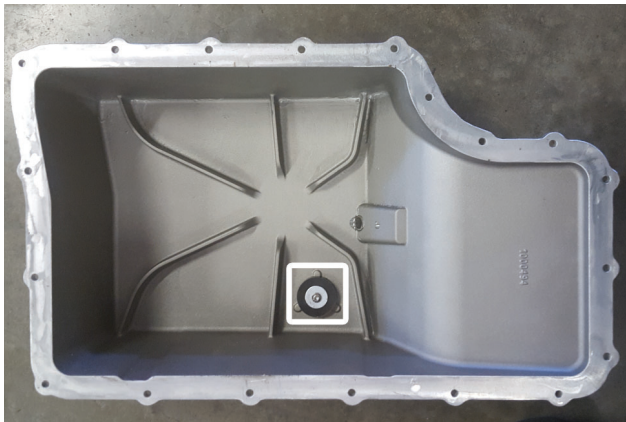

12. Install **screw (10)** through **lock washer (9)**, **oversized flat washer (12)**, and stock magnet (removed step 6) then into cast pan.



(This picture is intended for step 13)



13. Fasten transmission gasket and pan in place using (x19 ea.) **screws (4)** and **washers (5)**.



14. Fill your transmission fluid according to vehicle manufacturers procedure.

Congratulations, the installation of your **B&M Racing Performance Transmission Pan** is now complete!

