



Installation Instructions

Shift Improver Kit

1965-1987 Turbo Hydra-Matic 400 TH-400/TH-475 (3L80/3L80-HD)

Part Number 20260

© 2000, 2001 by B&M Racing & Performance Products

IMPORTANT NOTICE: Hydra-Matic introduced a revised transmission case just after the beginning of the 1988 model year. If you are installing the **B&M TH-400 Shift Improver Kit** in a late model vehicle which has had the transmission replaced after 1988 you must check the Julian date stamped on the transmissions I.D. tag (**See Fig. 1**) before attempting to install this kit. **Do not** use this kit (**#20260**) in transmissions built **on or after** November 23, 1987 (Julian date 327), use instead our **#20261 Shift Improver Kit** which is designed to be used with the new style case. If the I.D. tag is unreadable or missing you will have to remove the oil pan and valve body from the transmission to determine if your transmission has an early or late style case (**See Fig. 2**). This kit (**#20260**) will work correctly in all 1965 through 1987 TH-400 transmissions.

We recommend that you read through the instructions completely before beginning the installation so you can familiarize yourself with the installation procedure and tools required.

Check the tool list at the end of these instructions for the tools required to install your B&M TH-400 Shift Improver Kit.

Installation of the **B&M TH-400 Shift Improver Kit** can be accomplished by anyone with minimum mechanical experience. It is however, important to closely follow the instructions. Read each step carefully before proceeding, if you do not understand, go back and read the step again.

NOTICE: The **B&M TH-400 Shift Improver Kit** is not a cure-all for an ailing transmission. If your transmission is slipping, chatters or is in poor general shape, the installation of this Transpak may worsen the condition. However on a properly operating transmission in average condition, the **B&M TH-400 Shift Improver Kit** will provide the kind of transmission performance you are looking for.

When installing your **B&M TH-400 Shift Improver Kit** there are several other **B&M** performance products you may wish to consider:

TRANSMISSION OIL COOLER We feel that it is very important that every vehicle used in heavy duty and hi performance applications (racing, towing, RV, etc.) should have an oil cooler. Heat is the major cause of transmission failures, and an oil cooler is an inexpensive safeguard against overheating and transmission failure. **B&M** offers a wide variety of transmission cool-

ers to suit every application.

TRICK SHIFT PERFORMANCE ATF #80259 Trick Shift performance automatic transmission fluid is the industry's only real performance **ATF**. A specially blended oil with foam inhibitors, extreme pressure agents and shift improvers, this fluid assures protection while delivering the fastest possible shifts. You literally "Pour in performance."

DRAIN PLUG KIT #80250 The TH-400 transmission is not factory equipped with a drain plug. The **B&M** Drain plug kit is inexpensive and easy to install. It eliminates the mess of pan removal and gasket replacement normally required when changing fluid.

DEEP PAN #20289 **B&M** offers deep pans for the TH-400 transmission that provide 3 to 4 quarts additional oil capacity which significantly contributes to the cooling ability of the oil. No modifications to the dip stick are necessary and a fluid pickup extension is provided.

TORQUE CONVERTERS **B&M** offers a wide range of street torque converters for the TH-400 transmission. See your **B&M** dealer for details of the correct torque converter for your vehicle.

ADJUSTABLE VACUUM MODULATOR

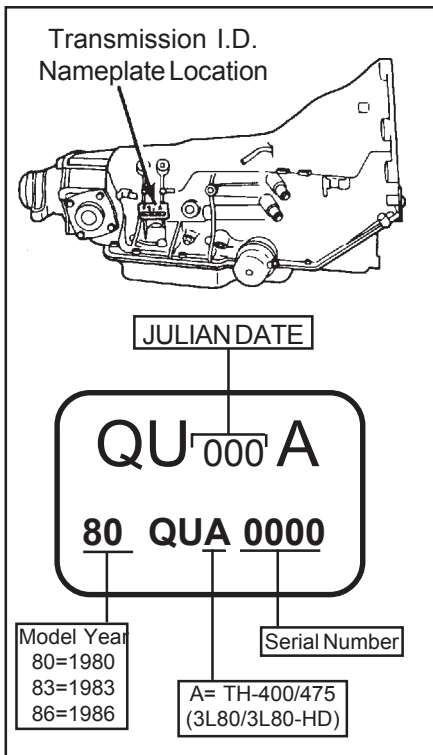

Figure 1

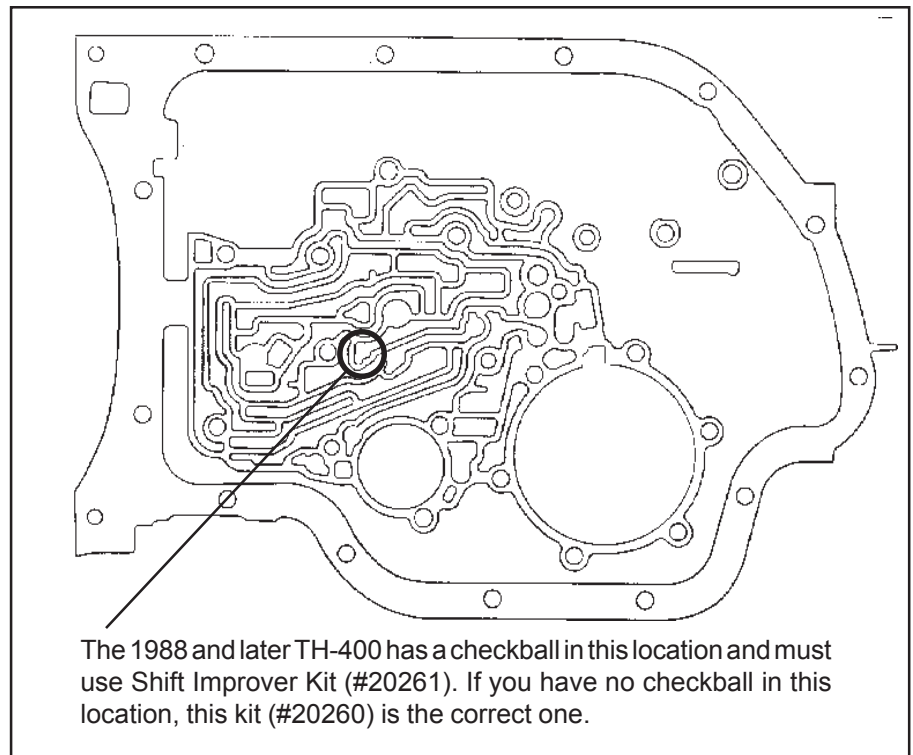

Figure 2

#20234 This replacement vacuum modulator for the TH-400 has the added feature of being adjustable. The adjustable feature allows you to tailor your shift points within a range of 2-4 mph.

FILTER SERVICE KIT #20287 The filter service kit replaces the stock factory filter with a special filter that uses a much finer felt micronic element which also has more total filter area so that the finer filtering element does not cut down on oil flow. This kit includes a special heavy duty oil pickup tube that is seated to the case with a double O-ring seal and is spring loaded to eliminate air leakage.

TEMPERATURE GAUGE KIT #80212 Most transmission and converter fail-

ures can be traced directly to excessive heat. The **B&M** transmission temperature gage can save you a costly repair bill by warning you ahead of time of an overheated transmission. The **B&M** temperature gage is extremely accurate and dependable, it comes with all necessary hardware and is easy to install.

B&M SHIFTERS; B&M manufactures a complete line of automatic transmission shifters ideally suited for use with the TH-400. These shifters provide you with positive transmission control as well as stylish appearance for your vehicles interior.

TH-400 KICKDOWN SWITCH #20297 When installing a TH-400 transmission

in a custom installation in place of a TH-350 or a TH-700 this kit provides a kickdown switch that will fit into the TH-350 or TH-700 throttle cable bracket.

INTRODUCTION

The **B&M TH-400 Shift Improver Kit** can be installed in a few hours by carefully following the instructions. Transmission components are precision fit, work slowly and do not force any parts. Burrs and dirt are the number one enemies of an automatic transmission. Cleanliness is very important, so a clean work surface from which oil can easily be removed is necessary.

This kit contains all the parts necessary to obtain two different levels of

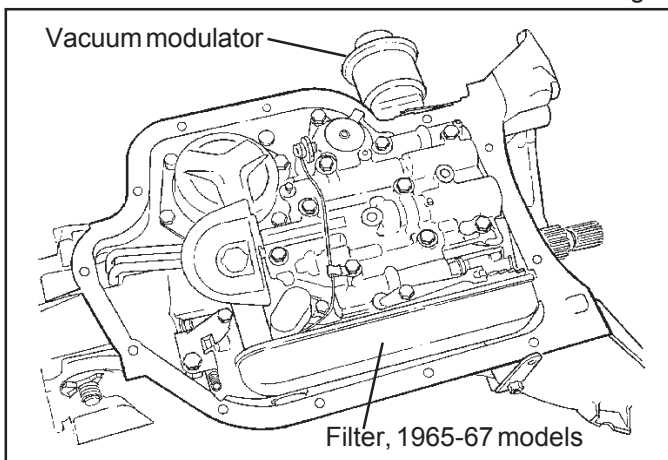

Figure 3 - 1965-67

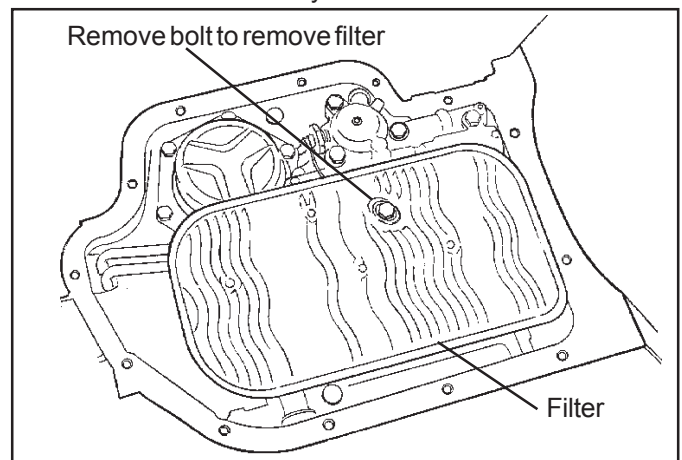

Figure 4 - 1968-87

performance, depending on the vehicles intended use:

1. **Heavy Duty**; Towing, campers, motor homes and 4-wheel drive vehicles. Heavy Duty level is a good starting place for light weight, high powered vehicles such as street rods. Heavy duty level produces firm noticeable shifts.

2. **Street**; Dual purpose performance vehicles, street and strip performance cars and, off road vehicles. Street level produces very firm, positive shifts.

DISASSEMBLY

Automatic transmissions operate at temperatures between 180°F and 240°F. We recommend that the vehicle be allowed to cool for several hours before attempting disassembly to avoid serious burns from hot oil and parts. The vehicle should be raised so there is at least 2 feet ground clearance for ease of installation and safety.

MAKE SURE THE VEHICLE IS RIGIDLY AND SECURELY SUPPORTED, JACK STANDS, WHEEL RAMPS OR A HOIST WORK BEST. DO NOT USE JACKS ALONE.

STEP 1. Have an oil drain pan ready to catch oil and a clean tray on which to put small parts so they won't get lost or dirty. Drain the oil by removing the rear pan bolts and work towards the front leaving the two front bolts in place. If the pan is stuck to the case pry the pan loose with a screw driver. Slowly remove the remaining two front bolts allowing the rest of the fluid to drain.

STEP 2. Oil filter removal. Two types of filters have been used on the TH-400:

Figure 3. 1964-67: This filter is a long box-like unit that runs along the drivers side of the case. Remove by grasping both ends of filter and pulling it straight down. Watch out for oil splatter. Remove the O-ring from the bore in the case if it did not come out with the filter oil pick-up tube. Be careful not to scratch the case bore when removing the O-ring.

Figure 4. 1968 and later: This filter is a large flat unit held to the transmission with a shoulder bolt. Remove the shoulder bolt and pull filter straight down. Some models also use a spacer between the filter and valve body. Watch out for oil splatter. If the oil pick-up tube

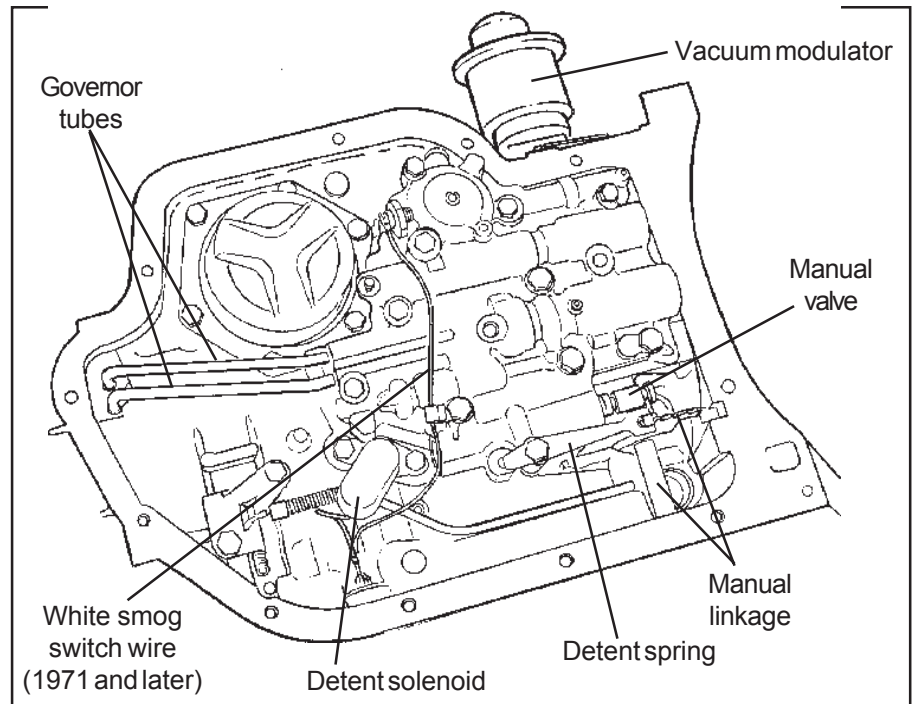

Figure 5

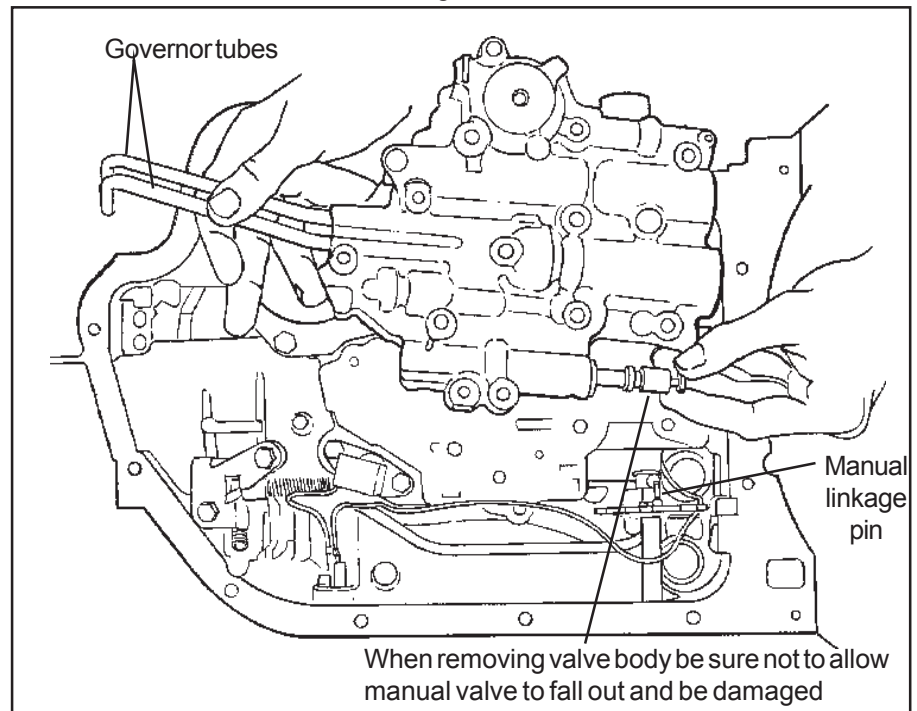

Figure 6

did not come out with the filter, pull it out. Remove the O-ring from the bore in the case if it did not come out with the oil pick-up tube. Be careful not to scratch the case bore when removing the O-ring.

STEP 3. Observe the location of the following (**See Fig. 5**) Manual linkage, detent spring with roller and the way linkage engages the manual valve in the valve body, governor tubes and their

routing, detent solenoid (oval or square can) and its wire connector, white smog switch wire ('71 and later) and routing of the wire.

STEP 4. There are (3) 1/4-20 and (8) 5/16-18 (10 some early models) bolts holding the valve body. Remove all but one valve body bolt and disconnect the switch wire if present. Hold the valve body in place and remove the last bolt. Lower the valve body while at the same

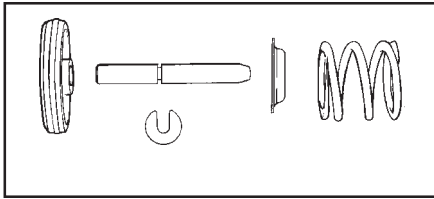

Figure 7

time pulling straight down on the governor tubes (See Fig. 6). Place the valve body in the oil pan to avoid contamination. **NOTE:** The front servo may fall out of the case, if it does see Figure 7 for reassembly order. Use grease or petroleum jelly to hold the servo components in place.

STEP 5. Use one (1) pan bolt to hold the separator plate in place while removing the solenoid. Remove the two bolts holding the detent solenoid (See Fig. 8) and allow the solenoid to hang by its wire. Remove the pan bolt and carefully lower the separator plate. Be careful not to loose the six (6) 1/4" steel check balls that are on top of the separator plate. The check balls will be used over again. Carefully remove all gasket material from valve body and oil pan surfaces of the case and valve body. All old gasket material must be removed before the valve body is reinstalled.

MODIFICATIONS

STEP 6. 2-3 Accumulator:

Heavy Duty : No modification required for this level.

Street: Very careful clamp the valve body in a vise and compress the accumulator enough to remove the E-ring (See Fig. 9). Open the vise slowly and remove the valve body. Remove the piston and accumulator spring, then reinstall the piston and the E-clip.

STEP 7. Separator Plate:

Heavy Duty: Drill the B&M Separator Plate orifice indicated in Figure 10 using the 5/32" (.156") drill supplied in kit.

Street: Drill the B&M Separator Plate orifices indicated in Figure 10 using the 3/16" (.188") drill supplied in kit.

STEP 8. Thoroughly clean the valve body and separator plate in clean solvent to remove any contamination. Remove any old gasket material stuck on the valve body channel surface.

REASSEMBLY

STEP 9. Check Ball Placement:

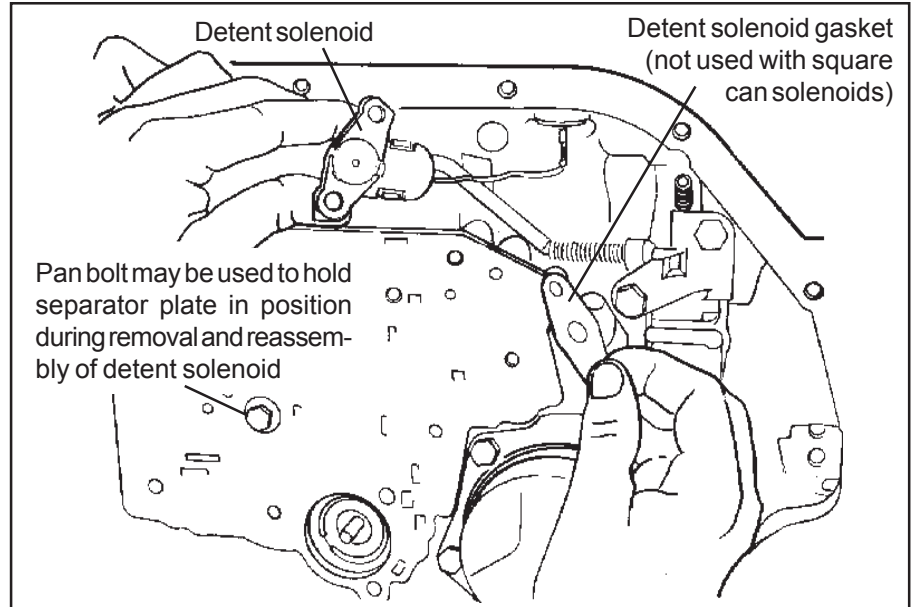

Figure 8

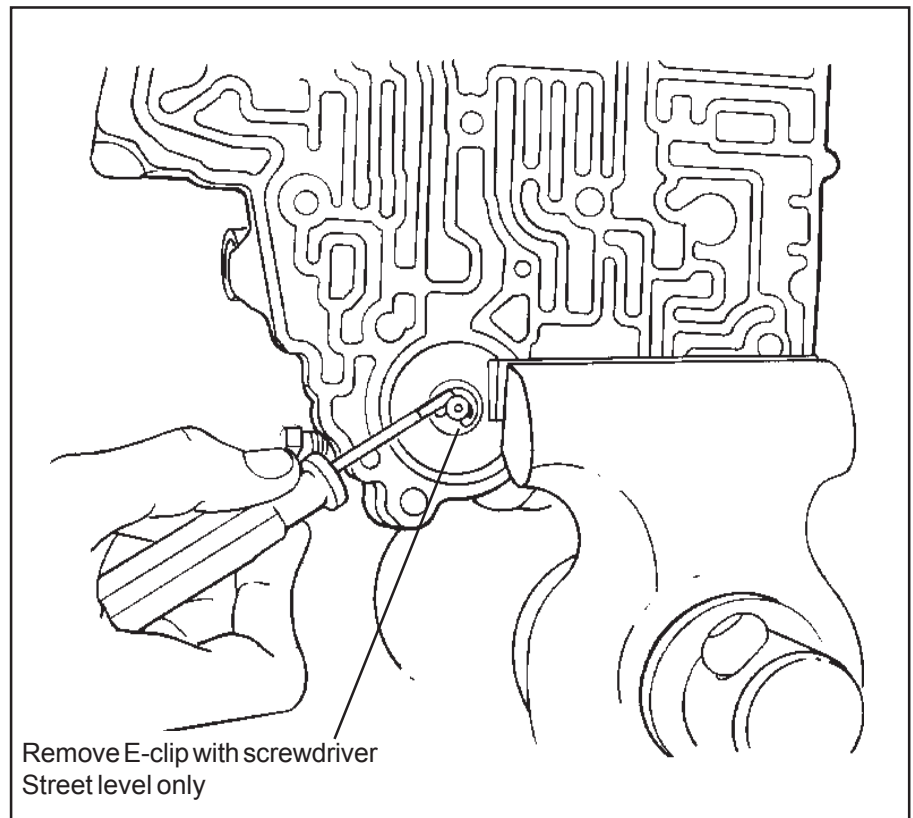

Figure 9

Install check balls in the locations shown in Figure 11 as follows:

Heavy Duty: Six check balls, one each, in locations 1-6.

Street: Three check balls, one each, in locations 4,5,6 (do not install check ball #1, 2 or 3).

STEP 10. Place upper valve body gasket (has "C" punched in it) on to the B&M separator plate (use grease or petroleum jelly to hold it in place).

Install the plate and gasket against the case and use a clean pan bolt to hold it in position for now (See Fig. 8).

STEP 11. Carefully examine Detent Solenoid.

Oval can solenoid: Make sure orifice disc is present and properly seated in the casting (See Fig 12). If the disc is missing the transmission will be in passing gear all the time. Install solenoid into position along with the new

metal gasket supplied with kit. Install the two (2) 1/4-20 bolts **FINGER TIGHT**. Remove the pan bolt you used to hold the plate and gasket in place.

Square can solenoid: Make sure the rubber seal is in good condition and has no nicks or cuts (**See Fig. 13**). If the seal is damaged, you will have to replace the solenoid. If the seal leaks the transmission will be in passing gear all the time. Install the solenoid into position, **DO NOT** use the metal gasket supplied in the kit. Install the two (2) 1/4-20 bolts **FINGER TIGHT**. Remove the pan bolt you used to hold the plate and gasket in place.

STEP 12. Insert the governor tubes into the valve body (**See Fig. 6**). Lay the lower valve body gasket (has "VB" punched in it) into position on valve body (use grease or petroleum jelly to hold it in place). Make sure the manual valve is in its bore. Install valve body onto transmission guiding the governor tubes into their holes at the rear of case. Push up on valve body and tubes and engage the manual valve on the shift linkage. Install one bolt to hold valve body in place.

STEP 13. Install all the valve body bolts **finger tight**. Make sure the detent spring is in position and riding on the internal shift lever (**See fig. 5**). Make sure the manual valve is engaged with the pin on the internal shift lever. Tighten all valve body and solenoid bolts to 8-10 lb.ft. (11-13.6 Nm). Route the white spark control wire and connect to pressure switch on valve body. Check operation of manual valve by running range selector through all gear positions.

STEP 14. Inspect your filter for damage or clogging. If it has more than 20,000 miles on it we recommend it be replaced. For longer transmission life and improved pump operation install **B&M Filter Service Kit No. 20287**.

STEP 15. Install two filter O-rings on filter pick-up tube (**See Fig. 14**). Lubricate O-rings with clean ATF then push pick-up tube and filter assembly up into transmission. On 1968 and later models install filter spacer (if present) and shoulder bolt then torque to 10 lb.ft (13.6 Nm).

STEP 16. Clean oil pan and scrape off any old gasket material from pan and case. You may want to install a **B&M Drain Plug kit** before installing the

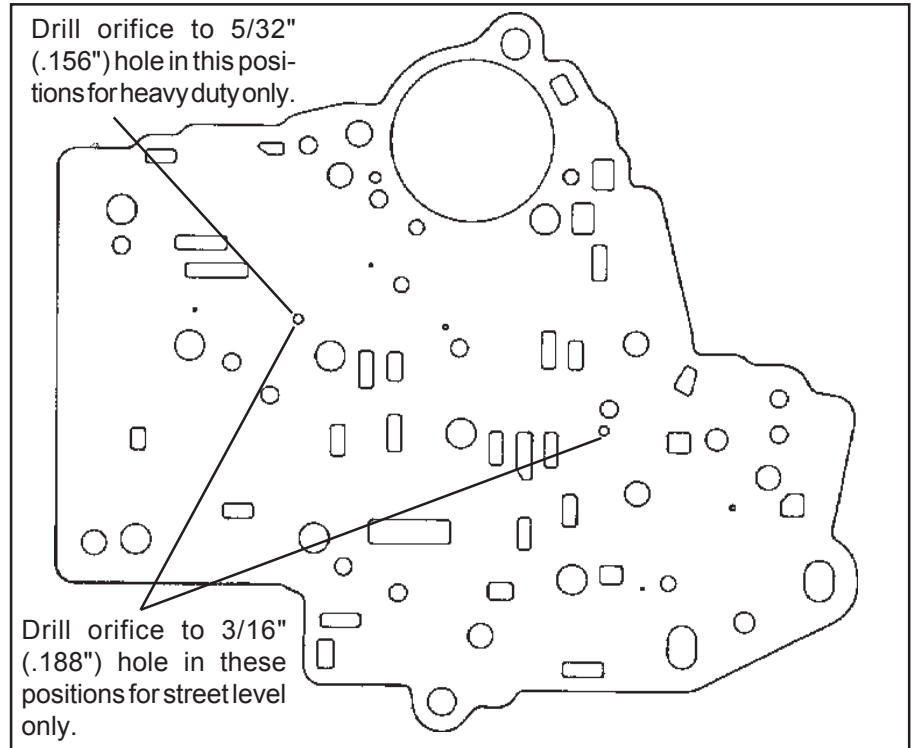

Figure 10

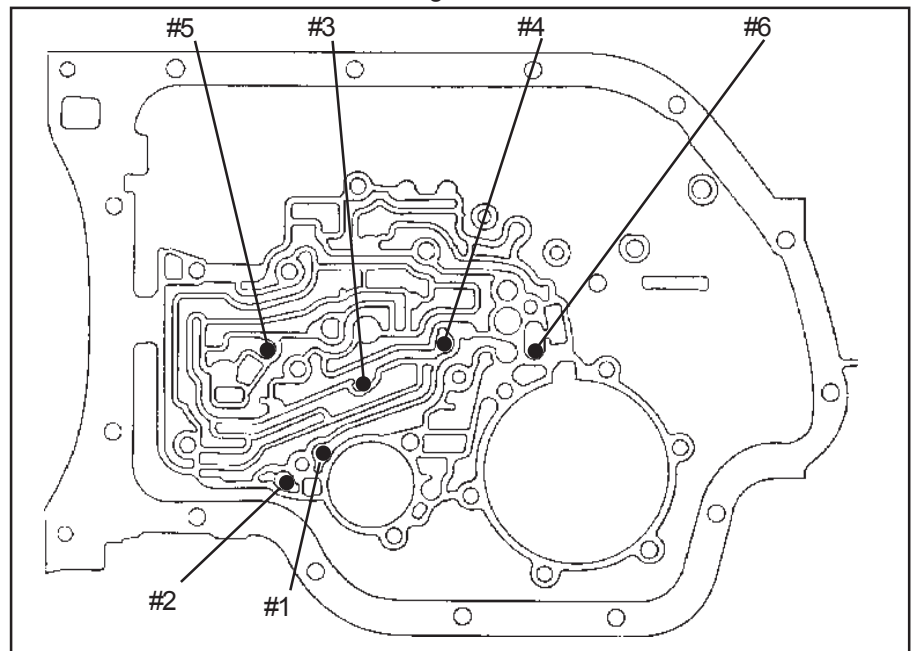

Figure 11

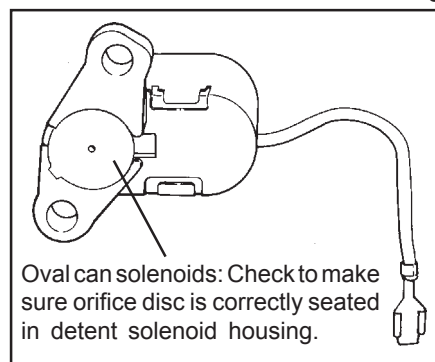

Figure 12

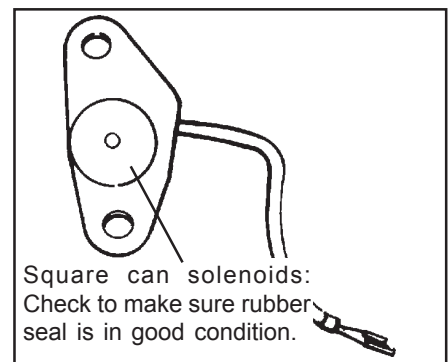

Figure 13

pan. The drain plug kit will help eliminate the mess when changing transmission oil. Install pan and new gasket and torque bolts 8-10 lb.ft (11-13.6 Nm).

STEP 17. Add 4 quarts of fresh ATF. Dexron II is fine for **Heavy Duty Level** applications however, we recommend **B&M Trick Shift ATF** for **Street and Competition Levels** for firm positive shifts and improved transmission life. With the vehicles wheels still off the ground, start the engine and shift transmission through all gears. Place selector in neutral and check the fluid level. It should be between the **Add** and **Full** marks. **Do not overfill !!** This can cause foaming and overheating. Stop engine and lower vehicle.

STEP 18. Drive vehicle several miles to warm up the transmission. Park on level surface and check ATF level. It should be between **Add** and **Full**.

Install two furnished O-rings on pickup tube. Lubricate thoroughly with oil before installation.

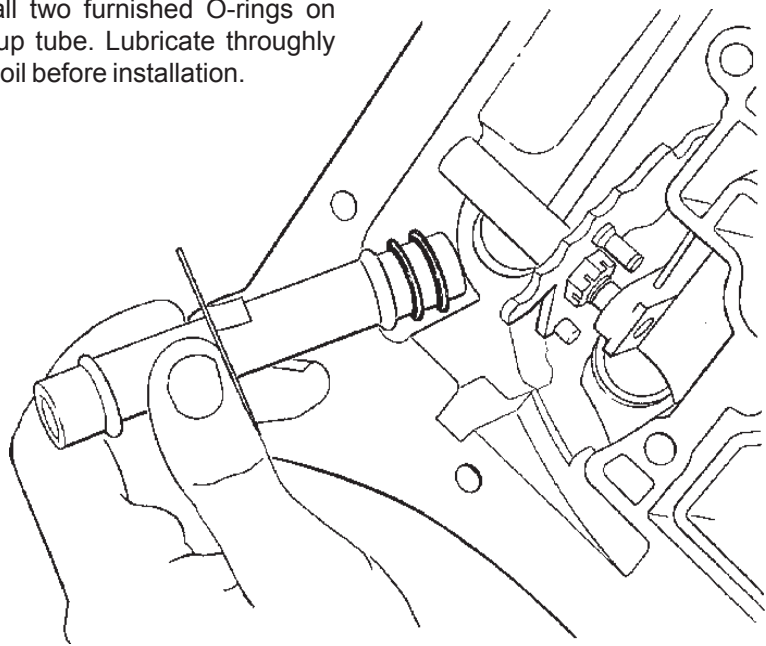

Figure 14

TOOL LIST

- 1 3/8" drive ratchet or speed handle
- 1 1/2" socket, 3/8" drive
- 1 7/16" socket, 3/8" drive
- 1 Small flat screwdriver
- 1 Small Internal Snap Ring Pliers
- 1 Small Hammer
- 1 Torque Wrench 0-10 lb.ft. (0-13.6 Nm)
- 1 1/4" Drill Motor
- 1 Vise

PARTS LIST

If you are missing any of the parts shown below, do not proceed. Contact your **B&M** dealer. Don't forget to purchase about 5 quarts of ATF (**See Step 17**).

- 1 20260 Instructions
- 1 Separator Plate
- 1 Oil Pan Gasket
- 1 Solenoid Gasket
- 1 5/32" Drill Bit
- 1 3/16" Drill Bit
- 1 Separator Plate/Case Gasket
- 1 Valve Body/Case Gasket
- 2 Filter Pick Up Tube O-Ring

TROUBLE SHOOTING GUIDE

Malfunction	Probable Cause
Slips	Valve body bolts loose. Low fluid level.
Overheating	Insufficient cooler capacity clogged lines or cooler.
Foaming oil at dipstick or breather	Fluid level too high. Clogged lines or cooler.
Erratic shifting	Vacuum line cracked or leaking. Shifter not properly adjusted. Kickdown switch not properly adjusted. Low fluid level. High fluid level. Valve body bolts loose. Kickdown solenoid loose.
Late hard shifts	Vacuum line cracked or leaking. Kickdown solenoid loose or damaged. Kickdown solenoid gasket damaged.
Will not shift	Kickdown solenoid loose or damaged. Governor tubes not properly installed.
Pump buzz or whine	Low fluid level. High fluid level. Cut, damaged or missing pick-up tube O-rings.