



# Torque Converter Installation Instructions for Chrysler Corporation A-904 and A-727

©B&M Automotive Products 1995

## IMPORTANT NOTES

1. This B&M Non lockup Converter will not fit 1978 and later Torqueflite transmissions originally equipped with lock-up converters.

2. 1971 and later engines with cast iron crankshafts require external balance weights. Using a B&M torque converter with one of these engines will require installation of a counter balanced B&M flexplate to prevent excessive and damaging vibration.

## INTRODUCTION

The torque converter in your automatic transmission is a unique device and must perform several functions:

**First**, it must provide slip at idle so the engine does not stall when the vehicle is stopped and the engine is running.

**Second**, it multiplies torque while vehicle is accelerating. The typical torque multiplication of a torque converter is about 2:1, when the vehicle is stopped. This means that the torque converter is actually doubling engine torque during initial acceleration. As the vehicle speed increases the torque multiplication decreases to 1.0:1. Some performance converters have stall torque multiplication as high as 2.6:1.

**Third**, the torque converter must have as little slippage as possible under normal driving conditions so the engine operates efficiently.

**Fourth**, the torque converter must have reverse coupling to slow the vehicle when you downshift to second or low. Traveler torque converters are designed to give maximum deceleration for improved engine braking.

All of the above functions occur automatically under various operating conditions. The torque converter is a simple and yet complex driveline component. Improper installation will result in poor performance and possible damage to the torque converter and/or transmission. This torque converter can be installed in a few hours by carefully following directions. Read all instructions first to familiarize yourself with the parts and procedures. Work slowly and do not force any parts. **Burrs and dirt are the number one enemies of an automatic transmission. Cleanliness is very important.** Avoid getting dirt or foreign particles in the transmission or torque converter.

Make sure the oil cooler and

cooler lines are clean. **The cooler and cooler lines should be back flushed if there was a previous transmission or converter failure.**

Automatic transmissions operate at temperatures between 150F and 250F. It is suggested that the vehicle be allowed to cool for a few hours to avoid burns from hot oil and parts. The vehicle should be off the ground for ease of installation. Jack stands, wheel ramps or a hoist will work fine. Make sure the vehicle is firmly supported!! Try to raise it 1-2 feet so you have plenty of room to work easily. Also have a small box or pan handy to put bolts in so they won't be lost, and a drain pan to catch oil. We suggest you rent a transmission jack from a rental yard to remove the transmission as the transmission/ converter assembly is heavy. A regular floor jack may be used if a transmission jack is unavailable.

Due to variations between different car models, exact instructions for every vehicle cannot be provided. These instructions are sufficient for all vehicle installations. You may find it necessary to disconnect and lower exhaust pipes during transmission removal.

**STEP 1.** Drain oil pan. This will make less of a mess during transmission removal. Some model Torqueflites have drain plugs. If yours has a drain plug, remove it and allow the fluid to drain, then install drain plug back into pan. If you do not have a drain plug, you should consider installing a B&M Drain Plug Kit, #80250, while transmission is out of the vehicle. If your transmission does not have a drain plug, loosen the oil pan bolts to allow the fluid to drain. After the fluid has drained, snug the oil pan back into place. You may wish to service your transmission while changing the converter

**STEP 2.** Remove driveshaft. Be careful not to damage the smooth bushing diameter on slip yoke models. Do not let the cups fall off the U-joint crosses. You may lose some of the needle bearings if the cups fall on the ground. It is a good idea to tape the cups to the U-joint cross, so they won't fall off. Now is a good time to clean and inspect your U-joints.

**4 Wheel Drive Models:** Remove front driveshaft also.

**STEP 3.** Disconnect throttle pressure linkage. (see fig. 1) Loosen pinch bolt on throttle lever and pry linkage off throttle pressure shaft. Disconnect rod connecting throttle pressure bellcrank to carburetor and al-

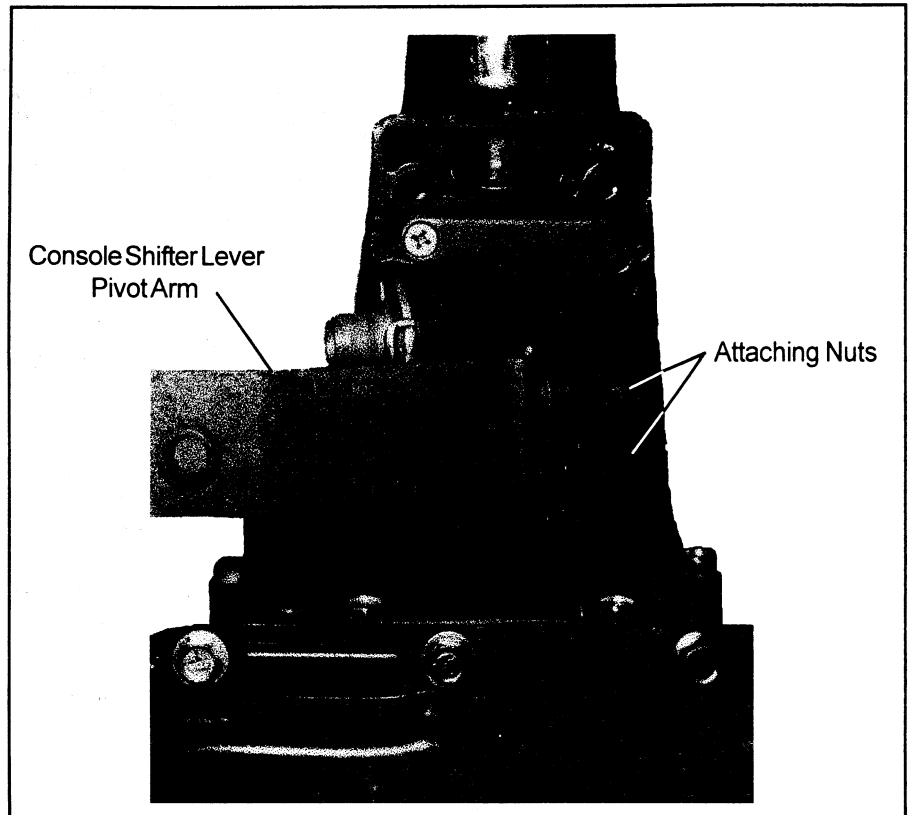

Figure 2

low it to hang free. Disconnect shifter as follows:

**Column Shift Models ('66 and later):** Loosen pinch bolt on shift lever and pry linkage off shift lever shaft (see fig. 1). Allow linkage to hang free.

**Console Shift Models ('66 and later):** Loosen pinch bolt on shift lever and pry linkage off shift lever shaft. Allow linkage to hang free. Remove two nuts and re-

move shifter pivot arm from extension housing. (see fig. 2)

'70 and later vehicles with locking steering columns; Unbolt bellcrank pivot from transmission bellhousing mounting point and allow park lock linkage to hang free.

**4 Wheel Drive Models:** Remove knob from transfer case shift lever.

**STEP 4.** Disconnect speedometer cable.

**STEP 5.** Disconnect oil cooler lines. Use a fitting wrench, if available, to avoid damage to compression nuts. We recommend that the oil cooler lines be flushed out to remove any foreign particles trapped in the cooler. Cooler lines should be flushed in both directions with solvent and air under pressure.

**STEP 6.** Remove dipstick and tube assembly. Remove torque converter access cover bolts and access cover (see fig. 3). Remove flexplate to converter bolts (see fig. 3). Use engine rotating tool or starter motor to "bump" each bolt into position.

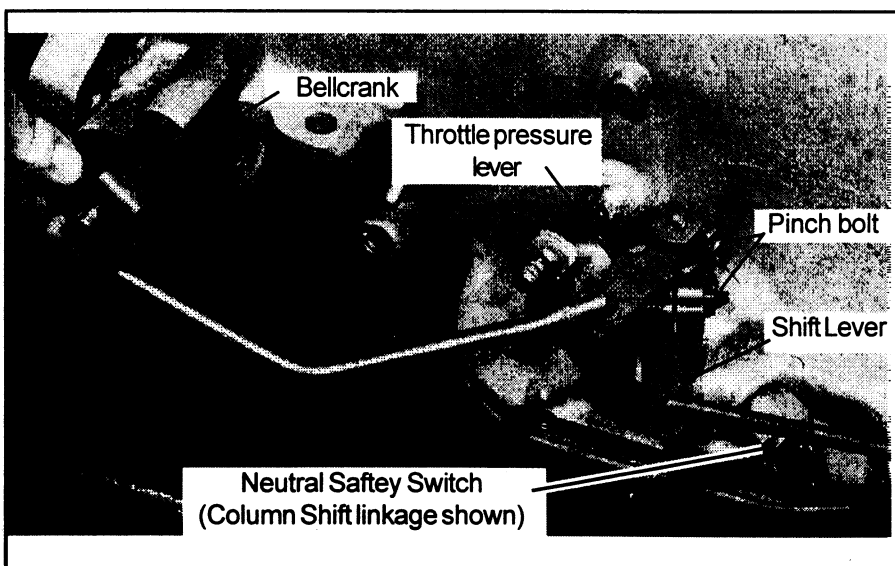

Figure 1

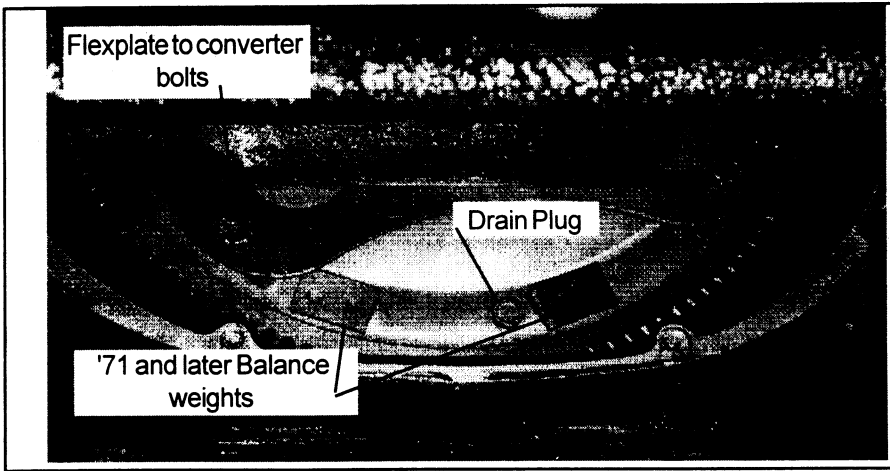

Figure 3

**STEP 7.** Disconnect neutral safety wiring (see fig. 1). Pull wiring connector off neutral safety switch and let it hang free.

**STEP 8.** Remove starter motor assembly and tie it up out of the way. On some vehicles, it is difficult to remove the starter completely, so it is easier to simply support it out of the way.

**STEP 9.** Support the transmission with a jack. Remove the transmission rear mount bolts. Raise the transmission slightly and remove the crossmember. Be sure the

transmission jack supports the transmission on a wide area so you don't crush the oil pan.

**STEP 10.** Remove any engine to transmission straps your vehicle may have (usually found on vans and trucks). Remove bellhousing bolts. Some "A" engines will require oil filter removal to remove one transmission bolt. Lower transmission until engine is supported. Pull transmission back slightly away from engine. Make sure converter stays with transmission. Lower transmission/converter

assembly and remove from vehicle.

**Caution:** 4 Wheel Drive Vehicles: Transmission/converter transfer case assembly is heavy. Exercise care during removal.

**STEP 11.** Pull converter off the front of the transmission. Some oil will leak out at this time. If you plan to store your original torque converter, drain it and cover the impeller hub opening to prevent entry of dirt.

**STEP 12.** Inspect your engine block. Make sure there are no burrs that will prevent the transmission from bolting down flat against the engine. File off any burrs that may be present. Dowel pins should stick out of the engine block a minimum of 1/2" for proper engagement (see fig. 4). Insufficient dowel pin engagement can cause front seal and/or bushing failure due to improper engine/transmission alignment. Bellhousing bolts alone will not align the transmission properly.

**STEP 13.** Inspect your flexplate. Check for distortion, excessive warpage or worn/elongated bolt

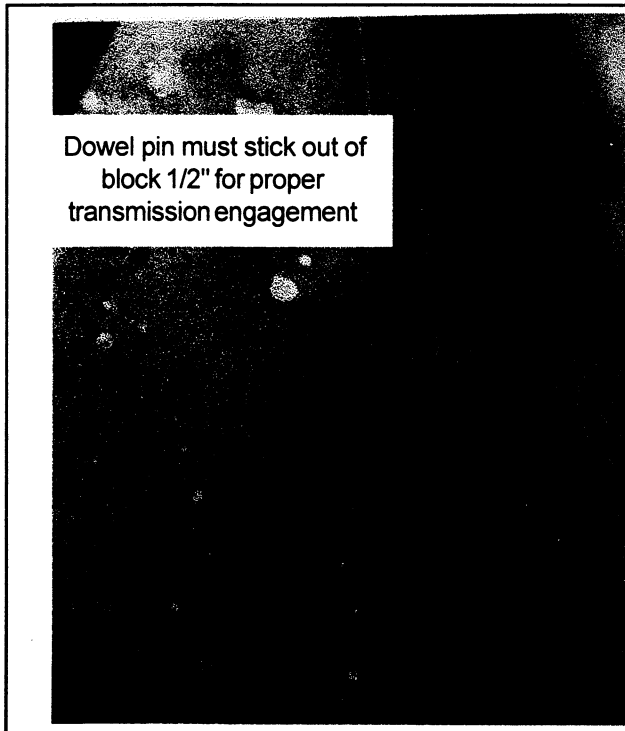

Figure 4

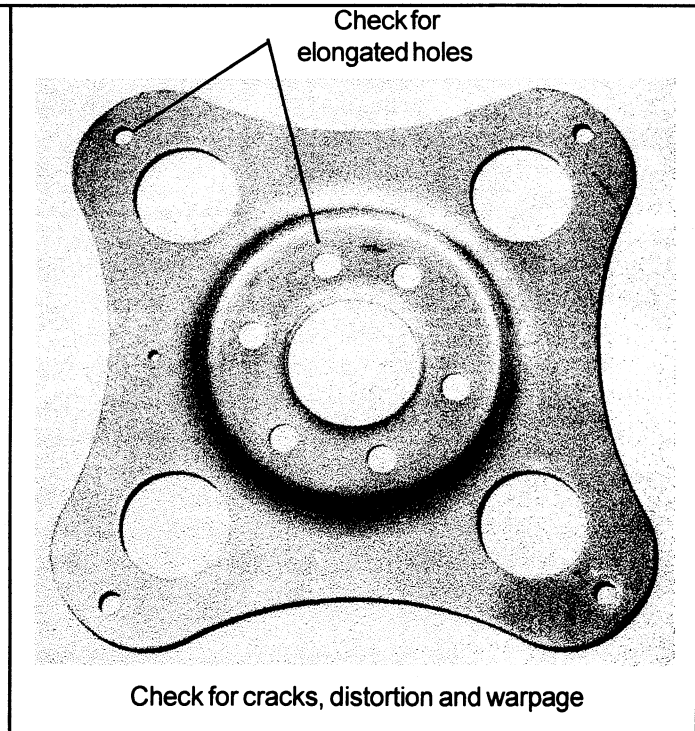

Figure 5

holes (see fig. 5). The flexplate should not be bowed backwards. Distorted flexplates should be replaced.

**STEP 14.** Check the bolt pattern on your B&M torque converter and make sure it matches your flexplate.

**Note:** One mounting hole is offset so the converter will only line up in one position. There are three bolt patterns used by Chrysler depending on engine:

**Wedge Type A-727:** Four-5/16" bolts on a 11-1/8" diameter circle.

**Hemi Type A-727:** Four-7/16" bolts on a 10" diameter circle.

**340-360 A-727 & A-904 Type:** Four-5/16" bolts on a 10" diameter circle.

If your stock flexplate does not match up to the bolt pattern on your B&M torque converter, you will have to replace your flexplate. You may have to enlarge your original flexplate holes to accept larger bolts, if necessary. Use a drill size 1/32" larger than bolt diameter and deburr the holes after drilling (see fig 6).

**Important Note:** Chrysler began producing cast-iron crankshafts in 1971. These crankshafts require external balance weights (which are normally attached to the torque converter) to balance the engine. B&M Torque Converters are dynamically balanced without any crankshaft balancing weights and cannot be directly substituted for an externally balanced torque converter or severe vibration will occur. B&M manufactures counter balanced flexplates for these applications which allows the use of a B&M converter with a cast iron crankshaft equipped engine (see fig. 7). Inspect your stock torque converter. If there are one or more balance weights spot welded between two drive lugs on the front of the converter (see fig. 3), you must use one of the following flexplates for proper engine balance:

Converter & Part Number	Bolt Pattern on B&M Converter	Flexplate and Modifications
Traveler 10402 (12") A-727	5/16" x 11-1/8" B.C.	Stock flexplate or B&M flexplate
Holeshot 2400 10415 (11") A-727	5/16" x 11 1/8" B.C. or 5/16" x 10" B.C.	Stock flexplate or B&M flexplate
Holeshot 3000 10425 (10") A-727	7/16" x 1 0" B.C. or 3/8" x 10" B.C.	Drill stock flexplate or B&M flexplate
TorkMaster 2000 10416 (11") A-727	5/16" x 11 1/8" or 5/16" x 10" Diameter	Stock flexplate or B&M Flexplate

Figure 6

**Note:** 1975 and later vans come from the factory with engine timing marks stamped on the outside diameter of the torque converter. This timing mark is visible through a hole in the bellhousing of the transmission. Since B&M torque converters do not have these timing marks, van owners will have to use the timing marks on the harmonic balancer on the front of the engine to check engine timing.

B&M Flexplate Part Number	Application
10234 .....	1971 to '76 340 C.I.D. TF 904
10235 .....	1971 to '76 340 C.I.D. TF 727
10236 .....	1971 to '92 360 C.i. D. TF 727
10237 .....	1972 and later 383 C.I. D. TF 727
10237 .....	1972 and later 400 C.I. D. TF 727
10237 .....	1973 and later 400 C.I.D. with cast crank (A-120) TF 727
10238 .....	1975 and later 440 C.I.D. with forged crank (A-134) TF727
10239 .....	1971 to '92 360 C.I.D. TF 904
10241 .....	1993-'95 360 C.I.D. TF 904
10242 .....	1993-'95 360 C.I.D. TF 727

Figure 7

**STEP 15.** Install flexplate onto crankshaft if you have removed or replaced it. When properly installed the flexplate is offset towards the engine. Install flexplate to crankshaft bolts and torque to 55 lb.ft.

**STEP 16.** Install B&M torque converter against crankshaft and flexplate. The converter should fit the crank snugly with no excessive slop. A tight fit may indicate burrs or rust in the pilot diameter of the crank. This can be cleaned with some emery paper or a file. If your flexplate is new or in good condition the converter may not contact

the flexplate before it bottoms in the crankshaft. A 1/16"-1/8" gap is normal. When the flexplate to converter bolts are tightened, the flexplate will bow backwards slightly and hold the torque converter against the crankshaft.

**STEP 17.** Install new pump seal supplied with converter. Lubricate front pump seal with ATF or grease. Pour 1 quart of B&M Trick Shift ATF into the B&M torque converter so there will be some lubrication on initial start up. If B&M Trick Shift ATF is unavailable, use the factory recommended fluid.

**STEP 18.** Install B&M torque

converter onto transmission. Push and rotate converter to engage input shaft, reaction shaft and oil pump rotors. Place a straightedge across the face of the transmission bellhousing. Measure the distance from the face of the bellhousing to the face of the torque converter drive lug. (see fig. 8) The drive lug must be at least 1/2" inside the bellhousing. A measurement of less than 1/2" indicates the torque converter is not fully engaged in the transmission. (Except for race torque converters specially built for applications using a motor plate, subtract the thickness of your motor plate from the 1/2" dimensions for proper measurement). Continue to rotate and turn the converter to obtain full engagement. If you install the transmission without full converter engagement, you will damage the oil pump and/or converter.

**STEP 19.** Place transmission in position on transmission jack. Be sure the jack supports the transmission on a wide area so you don't crush the pan. Install transmission/torque converter against engine. Transmission should engage dowel pins and sit flat against the engine block with hand pressure only. If the transmission will not sit flat against the engine, the converter is not installed into the transmission all the way or there is some interference problem. Do not attempt to pull the transmission up against the engine with the bellhousing bolts as this can cause transmission and/or torque converter damage. **STEP 20.** Once the transmission is in position against the engine, install transmission bellhousing bolts and tighten 25-30 lb.ft. At this point, the torque converter should spin freely. A tight converter indicates improper pump engage-

ment, badly burred crankshaft or distorted flexplate. This condition must be corrected before going any further. Install engine to bellhousing straps if your vehicle is so equipped.

**STEP 21.** Inspect rubber transmission mount. Worn, cracked or oil soaked transmission and/or engine mounts should be replaced. Raise transmission and install crossmember and transmission mount bolts securely. Install starter motor. Install starter bolts and tighten securely. Connect neutral safety switch wire or connector.

**STEP 22.** Install four flexplate to converter bolts. After the first bolt is installed snugly, use engine rotating tool or starter motor to "bump" each bolt location into place. The bolt pattern on the flexplate is keyed so the converter can only install one way. After all bolts are in place, tighten bolts to the following specifications: 5/16" to 20-25 lb.ft., 3/8" to 30-35 lb.ft., 7/16" to 40-45 lb.ft. Install converter access plate and tighten bolts to 8 lb.ft.

**STEP 23.** Install dipstick and tube assembly. Use a small amount of sealer at the O-ring to prevent leaks. Connect oil cooler lines. Use a fitting wrench on the compression nuts to avoid damage to the nuts and hold the fittings with a wrench while tightening compression nuts to 75 lb.in..

**STEP 24.** Connect speedometer cable:

'62-'65: Push speedometer cable assembly into extension housing. Install bolt and tighten to 150 lb.in.

'66 and later: Push speedometer cable into speedometer housing and tighten sleeve.

**STEP 25.** Connect shifter:

Rod Shifters, all ('66 and later): Align shift lever over shift shaft on transmission. Tap lever down into position and engage flat on shift shaft. Tighten pinch bolt securely. Place shifter in the Park position. Loosen the pinch bolt on the shifter rod (which is located on the end of the rod away from the transmis-



Figure 8

sion) and let the rod seek its own position. Tighten the pinch bolt and check the feel of the shifter. The detent (gear) position should be close enough to the stops in Neutral and Drive so that the shift selector lever will not remain out of detent position when placed against stop and released.

'70 and later vehicles with locking steering column: Install bellcrank pivot into mounting stud on bellhousing and tighten securely. 4 Wheel Drive models: Install knob on transfer case shift lever.

**STEP 26.** Install throttle pressure bellcrank onto bellhousing and tighten bolt securely. Install throttle lever over throttle pressure shaft and tighten pinch bolt securely. Note: All vehicles with a full automatic valve body must run throttle pressure linkage or severe transmission damage will result.

**STEP 27.** Install driveshaft. Make sure U-joint cups are installed properly. Tighten U-joint bolts and nuts securely.

**STEP 28.** Lower vehicle but keep the rear wheels off the ground, if possible. Add 4 quarts (A-904) or 6 quarts (A-727) of B&M Trick Shift to the transmission. If Trick Shift is unavailable use the factory recommended fluid.

**WARNING:** DO NOT start engine before putting fluid into transmission. Failure can occur in a matter of seconds.

**STEP 29.** Start engine and place shifter in the Neutral position. Add fluid until the oil level is between the Add and Full marks. Shift transmission through all gear positions. If the rear wheels are off the ground, allow the transmission to shift through all gears several times. Place selector in Neutral and check fluid level. Do not overfill. This can cause foaming and overheating. Check for leaks at cooler lines, etc.

## OPERATING RECOMMENDATIONS

**Torque Converter Performance**  
The torque converter is a component of the automatic transmission however it must be properly matched to the engine for maximum performance.

A torque converter reacts to torque. The more torque you put to the converter the better your performance. However this torque must match the operating RPM of the converter. To make a converter operate properly, your engine must make sufficient bottom-end torque. You cannot build an engine for an automatic transmission the same way you would build an engine for a 4-speed because the operating ranges are different. Your engine must be built to produce as much bottom-end and mid-range torque possible for your operating conditions. This is especially important for good street performance. Do not make the mistake of over-camming your engine. You should limit camshaft duration to 270° @ .050 for street engines and 290° @ .050 for race engines. We also suggest you run the cam 2°-4° advanced. Small CFM carburetors give better bottom-end response. Be careful not to over carburate your engine.

Since most people discuss torque converters in terms of stall speed, the following chart will give you an idea of the stall speed increase or decrease you can expect from your B&M torque converter compared to a stock torque converter.

### CONVERTER INCREASE

Traveler	300-400 RPM
Holeshot 2000	600-800 RPM
Holeshot 3000	1000-1200 RPM

This is a general guide and should be used as an approximation only. A specific stall speed cannot be guaranteed because of the many variables involved in each engine/

vehicle combination. If you are experiencing difficulties with your converter selection, the following items can contribute to low stall speeds:

- Light cars
- Low torque output
- Very high compression ratios
- Large throttle bore carburetors
- Carburetor secondary linkage
- Long duration camshafts
- Retarded cam timing
- Poor rear brakes
- High-ram manifolds
- Multiple carburetion

Low stall speeds, poor throttle response, sluggish performance and high idle speed requirements indicate poor bottom-end torque characteristics which should be corrected to obtain maximum converter performance.

Modified torque converters are installed to improve performance and durability not available from a stock torque converter. Heavy Duty and racing applications impose higher loads and greater heat dissipation than stock operating conditions. The following recommendations are provided so you can obtain maximum performance and benefit from your B&M torque converter.

**Oil Cooling:** The factory heat exchanger is usually inadequate for Heavy Duty and/or Racing applications. B&M Oil Coolers are recommended for performance applications (see back page). Heat is the major enemy of automatic transmissions and a cooler will prolong the life of your transmission.

### Driving Techniques

#### Traveler:

Traveler torque converters should be driven like a stock torque converter. Stall speeds and converter slip will coincide with torque demand and adjust automatically. Additional deceleration will be noticed during manual downshifts.

**Holeshot:**

Holeshot converters are designed for street performance and should not be considered as a low cost race converter. Under normal driving conditions Holeshot torque converters will function like stock converters with some additional slip. High stall speeds are available at torque demand. The best standing start acceleration performance is usually obtained by "stalling" the converter at 1500-2000 rpm with the brakes locked just prior to launching the car. Bang the throttle and release the brake pedal at the instant of launch. Marginal traction situations may require you to "drive the car out" or feel for traction with the gas pedal as you leave the starting line. Remember, Holeshot torque converters are designed for street performance and occasional drag strip use. Race cars need Race converters.

**Maintenance:**

**Street Use:** Change fluid and filter every 10,000-12,000 miles. This will also help the life of the transmission. Check torque converter bolts or nuts every 20,000-24,000 miles.

**Ballooning:** Ballooning is expansion of the torque converter along the axis of rotation (front to back). This is caused by high rpm use and/or continuous wide open throttle stall speeds. A ballooned converter can lose thrust washer piloting and must be cut open for repair. You can check for ballooning by measuring the end play clearance of the stator and turbine (see fig. 9). You will have to make a hooked tool to grab the stator or turbine (see fig. \*\*). Maximum stator or turbine end play is .050 inch. If stator or turbine end play exceeds .050 inch the converter will have to be re-

paired.

**Cracks and Leaks:**

Leaks can be caused by several reasons. The most common are front seal failure and cracks.

Front seal failure can be caused by one of the following; improperly installed seal (damaged during installation), converter misalignment, worn pump bushing, or worn impeller hub. A ballooned converter can have a slightly bent impeller hub. Inspect the pump bushing when you replace the

seal. Check dowel pins in the engine block for sufficient engagement.

Cracks can develop in the welds surrounding the impeller and pilot hubs or perimeter weld from stress and vibration. If a crack occurs in these areas we recommend you return it for repair.

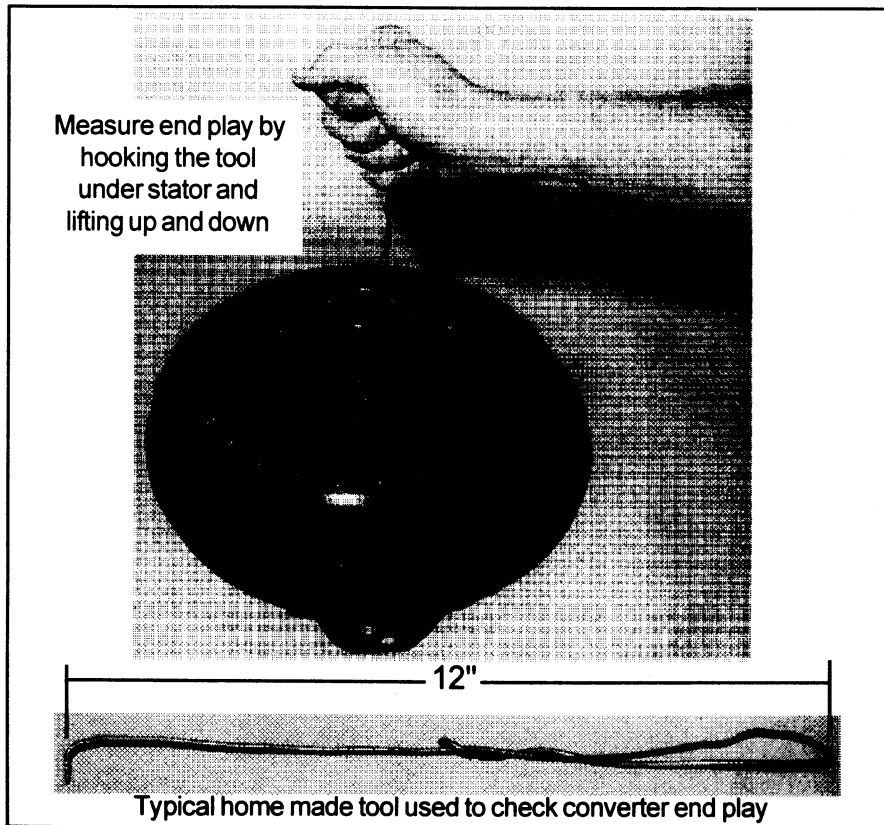

Figure 9