

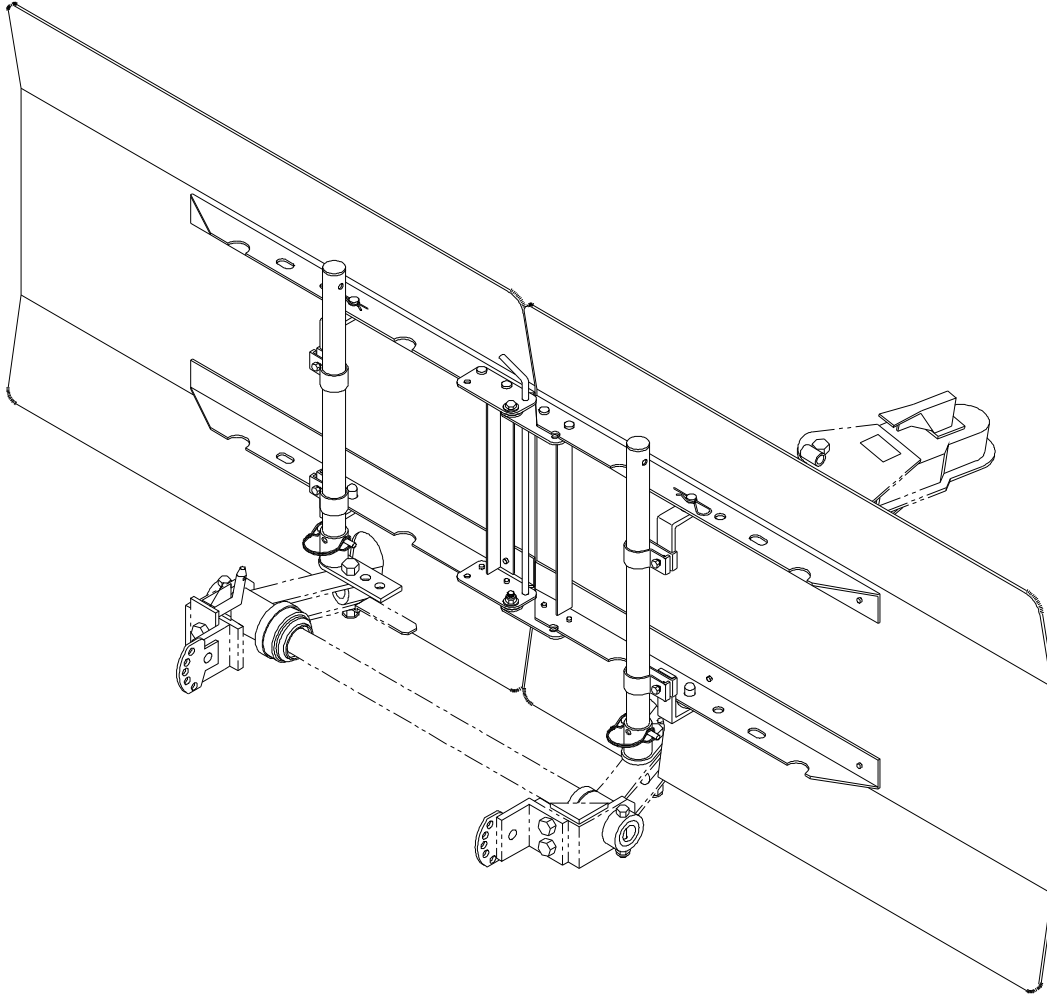

Strong As An Ox™

KARGARD™



OPERATOR, PARTS AND INSTALLATION MANUAL

**BX8870
KARGARD™**

Go RVing
Life's A Trip

INSTALLATION / STORAGE

DO NOT INSTALL, OR USE THIS EQUIPMENT UNTIL THE FOLLOWING OPERATING AND INSTALLATION INSTRUCTIONS HAVE BEEN READ AND UNDERSTOOD.

The installation and storage instructions below are designed for everyday use. If installing your KarGard™ for the first time, refer to the detailed instructions for specific tow bars found on pages 2-6. Due to vast differences in towed vehicle front ends, these detailed instructions may have to be adjusted slightly or different mounting holes used than those referred to in the instructions and on the illustrations. If your tow bar is not specifically addressed, you should be able to adapt one of these sets of detailed instructions to aid in your particular installation.

To mount this KarGard to a RoadMaster® StowMaster® tow bar, an adapter kit (BX8871) is required, which can be purchased from your local Blue Ox dealer.

INSTALLATION FOR TOWING

1. Hook up your tow bar for towing.
2. Remove the locking rod and unfold the KarGard. Remove the tower assemblies from their storage slots and install them into the tower bases. Pin them in place using the spring lock pins.
3. Insert the locking rod into the center hinges to keep the KarGard straight.
4. Set the KarGard onto the dowel pins (bottom first) then install the hair pins into the upper dowel pins to secure the KarGard in place.
5. The KarGard is installed and ready for towing.

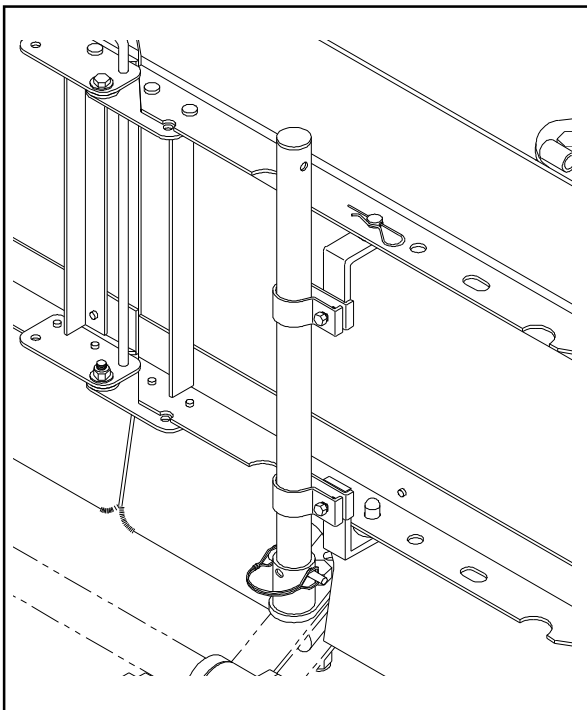

REMOVAL FOR STORAGE

1. Pull the hair pins from the dowel pins and remove the KarGard. Lay it flat on the grass to avoid scratching the surface. (aluminum angles up) Insert the hair pins into the dowel pin holes to prevent loss.
2. Remove the spring lock pins and towers from the tower bases. Insert the spring lock pins through the storage holes in the top of the tower assemblies. By using these holes, the tower assemblies will not slide out when stored inside the folded KarGard.
3. Lay the tower assemblies in the storage slots in the aluminum angles. Arrange them so you know which tower goes to which side to help avoid confusion when installing the KarGard next time.
4. Remove the locking rod, fold the KarGard then insert the locking rod to keep the KarGard folded.
5. Once folded, the locking rod or small aluminum angle at the hinged end can serve as a handle.

STORAGE

The edges of the KarGard may warp slightly during shipping or storage. When laid flat or installed on the towers, the KarGard should regain its original form. We recommend storing the KarGard folded, and laying flat.

NOTE: The material used in the construction of the KarGard has a good memory of its original shape. However, if the KarGard is subjected to abnormal circumstances causing it to be bent sharply, it may not regain its original shape. The manufacturer accepts no responsibility for any damage caused to the KarGard or to the towed vehicle resulting from the misuse of this product.

⚡ IMPORTANT ⚡

Note that the plastic material extends 12" beyond the rigid aluminum framework. This allows flexibility if you should turn too sharp and the motorhomes' bumper or roof access ladder hits the KarGard.

A recessed receiver, a short tow bar, or both, will greatly reduce the turning radius, especially if you have a roof access ladder on your motorhome. Be aware of this and check it the first time you turn a corner.

INSTALLATION (TUBE TYPE TOW BARS)

(Blue Ox Standard, Economy, Deluxe, Universal / Duncan A-Frame / Many others)

1. Mount the tow bar to the towed vehicle's baseplate, as if to tow it. Support the coupler on blocks or a stand at approximately the same height as your hitch ball.
2. Bolt the tower bases to the tow bar legs using the "U" bolts and nuts provided. Snug the nuts but do not tighten at this time. (See diagram below) Take care not to damage the threads.

NOTE: *If you have a tow bar that flips up for storage, raise it to the storage position to determine if the tower bases will interfere with this operation. If so, the tower bases can be mounted underneath the tow bar legs as shown on the left leg in the diagram below.*

Refer to diagram on page 4 for steps 3-10.

3. Set the towers into the tower bases (plastic plugs up) and install the spring lock pins. Align the towers parallel with each other, close to vertical, tighten the U-bolts firmly.
4. Assemble the tower clamps to the upper and lower "L" brackets so you have four bracket assemblies, an upper and lower right and an upper and lower left. Be sure to orient the clamps and "L" brackets as shown on page 4. Slide a rubber washer over each of the four dowel pins on the "L" brackets.
5. Slide the four bracket assemblies onto the towers. Snug to keep in place but do not tighten at this time.

NOTE: *"L" brackets with short pins with a hole through them are upper brackets.*

6. Remove the locking rod and unfold the KarGard. Install the locking rod to keep the KarGard straight. Set the KarGard on the tow bar legs. Slide the upper brackets up until the dowel pins fit through a hole in the upper aluminum angle of the KarGard, and install the two hair pins.

IMPORTANT: *Use any holes, but be sure to use the corresponding hole on the other half of the KarGard to keep the KarGard centered in front of the towed vehicle.*

Snug the upper brackets, but do not tighten at this time. Slide the lower brackets up until the dowel pins fit through the same holes in the lower aluminum angles as used in the upper angles. Snug the lower brackets, but do not tighten at this time.

7. Determine if you need to lower the KarGard to provide maximum protection of your towed vehicle lower valence. If you need to lower it, follow the instructions printed on the template supplied with the KarGard.
8. Once openings are cut, (optional) reinstall the KarGard onto the dowel pins (bottom first) and install the hair pins. Slide all mounting brackets and the KarGard down and tighten the mounting brackets.

NOTE: Allow approximately 1/4" clearance between the bottom of the KarGard and the top of the tow bar legs. Distances may vary due to tow bar configurations. Keep KarGard parallel with the ground.

9. Tighten all bolts firmly. Make it a habit to check all fasteners occasionally for tightness.
10. Lift the front of the tow bar up until the towers almost touch the front of your towed vehicle. This will show you how much of a dip or rise you can go through before contact occurs. This is a judgement that only you can determine. You may need to adjust the tower bases forward slightly if clearances appear too close.

The manufacturer accepts no responsibility for any damage caused to the KarGard or to the towed or towing vehicle from improper installation of this product.

Be sure to read page 1 where you will find important information about your KarGard, as well as installation and storage instructions for everyday use.

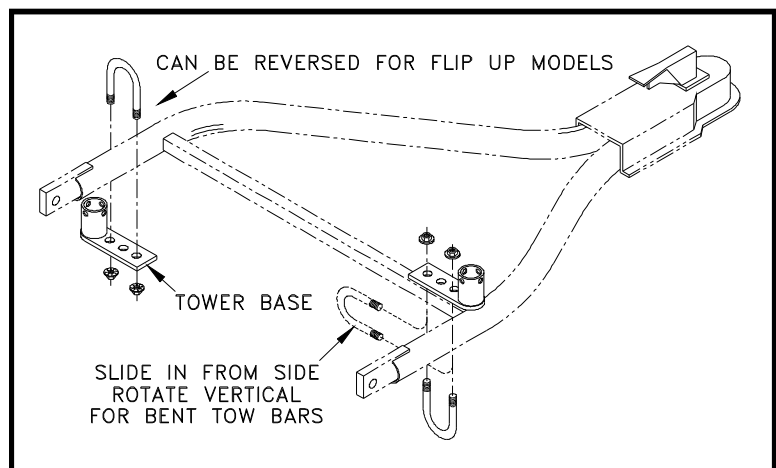

INSTALLATION (BLUE OX SELF-ALIGNING TOW BARS)

- 1. Refer to page 4 while installing the KarGard.** Mount the tow bar to the towed vehicle's baseplate, as if to tow it. Support the coupler on blocks or a stand at approximately the same height as your hitch ball. (Aventa tow bars - same height as your hitch receiver)

IMPORTANT: DO NOT hook the tow bar to the towing vehicle. During installation, bolts will be removed and the hook up will make it difficult to remove bolts.
- 2. Remove the 1/2" grade 5 bolts attaching the chrome tow bar legs to the tabs.** Set the tower bases on top of the tabs and fasten using the 1/2 x 3 grade 5 bolts and nylon insert lock nuts provided. Install them with the cups close to the front of the towed vehicle, and the same distance from the towed vehicle.

NOTE: How the tower bases are oriented will depend on what type of tow bar you have. Page 4 shows the orientation for the Rangefinder II tow bar. Orientation for an Aventa tow bar uses the center hole in the tower bases and the cups of the tower bases point straight backward. (See inset page 4) **Aventa II & Aladdin tow bars are shown on page 6. NOTE:** 2 - 1/2" washers may have to be used on each side as shown on page 6 so the tower base clears the rubber boot.

Snug the bolts, but do not tighten at this time. There should be two or more threads showing through the lock nut when snug. If this is not the case, obtain a longer bolt from a hardware store, but be certain it is Grade 5.
- 3. Fold your tow bar to the stored position to be certain that the tower bases will not interfere, adjust accordingly.** The tower bases will work in a wide variety of locations.
- 4. Set the towers into the tower bases (plastic plugs up) and install the spring lock pins.**
- 5. Lift the front of the tow bar up until the towers almost touch the front of your towed vehicle.** This shows you how much of a dip or rise you can go through before contact occurs. This is a judgement that only you can determine. You may need to adjust the tower bases forward slightly if clearances appear too close.
- 6. Assemble the tower clamps to the upper and lower "L" brackets so you have four bracket assemblies, an upper and lower right and an upper and lower left.** Be sure to orient the clamps and "L" brackets as shown on page 4. Slide a rubber washer over each of the four dowel pins on the "L" brackets.
- 7. Slide the four bracket assemblies onto the towers.** Snug to keep in place but do not tighten at this time.

NOTE: "L" brackets with short pins with a hole through them are upper brackets.
- 8. Remove the locking rod and unfold the KarGard.** Install the locking rod to keep the KarGard straight. Set the KarGard upright on the tow bar legs. Slide the upper brackets up until the dowel pins fit through a hole in the upper aluminum angle of the KarGard, and install the two hair pins.

IMPORTANT: Use any holes, but be sure to keep the KarGard centered in front of the towed vehicle.

Snug the upper brackets, but do not tighten at this time. Slide the lower brackets up until the dowel pins fit through the same holes in the lower aluminum angles as used in the upper angles. Snug the lower brackets, but do not tighten at this time.
- 9. Determine if you need to lower the KarGard to provide maximum protection of your towed vehicle lower valence.** If you need to lower it, follow the instructions printed on the template supplied with the KarGard.
- 10. Once openings are cut, (optional) reinstall the KarGard onto the dowel pins (bottom first) and install the hair pins.** Slide all mounting brackets and the KarGard down and tighten the mounting brackets completely.

NOTE: Allow approximately 1/2" clearance between the bottom of the KarGard and the top of the tow bar legs. Distances may vary due to tow bar configurations. Keep KarGard parallel with the tow bar cross bar. Tighten the 1/2" bolts that hold the tower bases firmly.

INSTALLATION (BLUE OX SELF-ALIGNING TOW BARS)

IMPORTANT: Overtightening causes difficulty in folding the tow bar, and undertightening causes looseness in the legs and tower bases. Make it a habit to check all fasteners occasionally for tightness.

The manufacturer accepts no responsibility for any damage caused to the KarGard or to the towed or towing vehicle from improper installation of this product.

Be sure to read page 1 where you will find important information about your KarGard, as well as installation and storage instructions for everyday use.

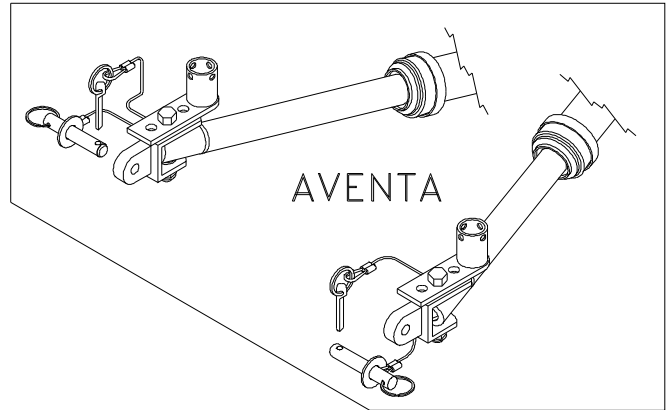
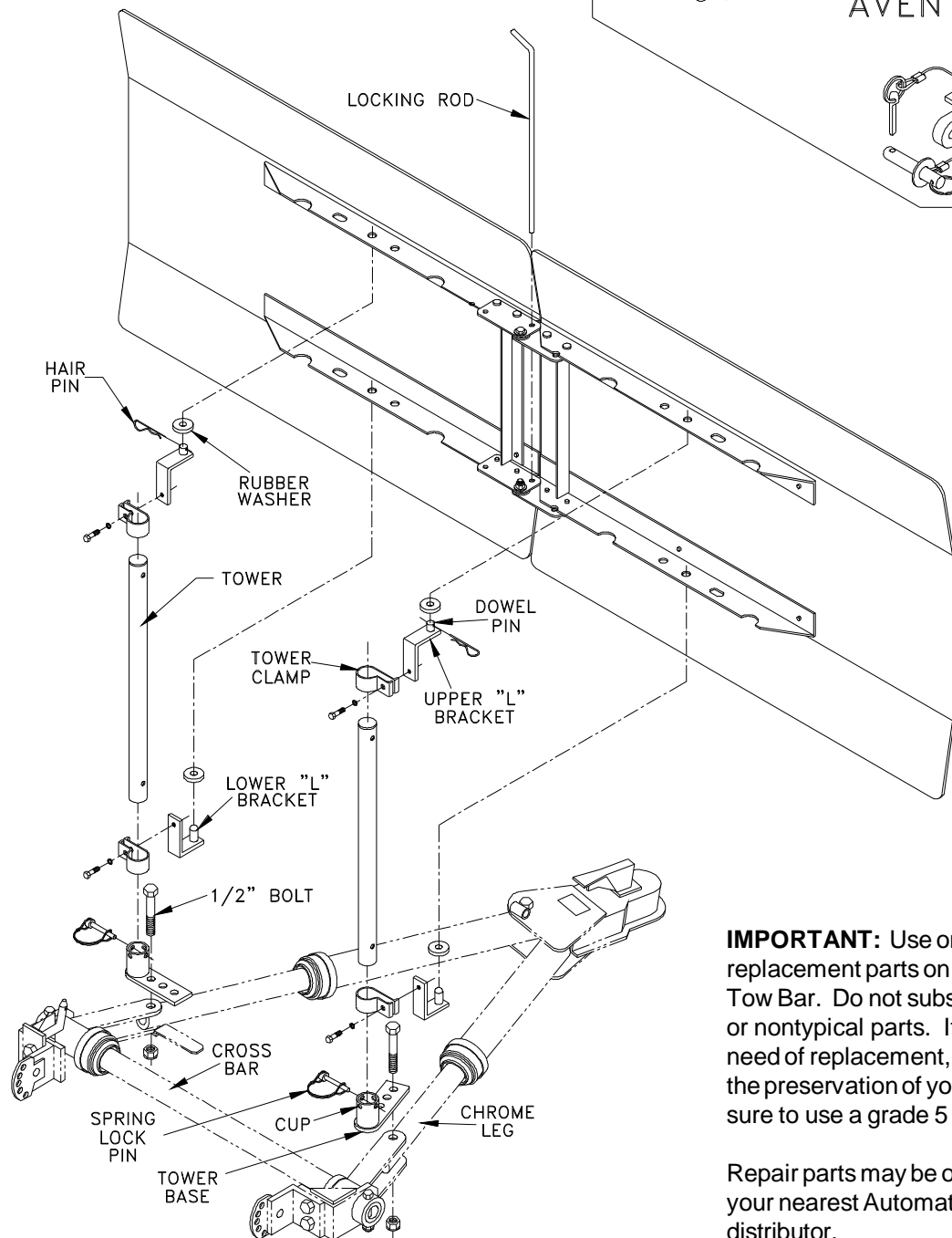

IMPORTANT: Use only genuine factory replacement parts on your KarGard and Tow Bar. Do not substitute homemade or nontypical parts. If a bolt is lost or in need of replacement, for your safety and the preservation of your equipment, be sure to use a grade 5 replacement bolt.

Repair parts may be ordered through your nearest Automatic dealer or distributor.

INSTALLATION (DUNCAN SELF-ALIGNING TOW BARS)

(Duncan EazAligner & TowMatic II Self-Aligning Tow Bars)

1. **Refer to page 6 while installing the KarGard.** Mount the tow bar to the towed vehicle's baseplate, as if to tow it. Support the coupler on blocks or a stand at approximately the same height as your hitch ball.
IMPORTANT: DO NOT hook the tow bar to the towing vehicle. During installation, bolts will be removed and the hook up will make it difficult to remove bolts.
2. Remove the tow bar from the quick attach receiver brackets. Remove the inside bolt holding the (PS) receiver bracket, and the outside bolt holding the (DS) receiver bracket to the cross angle. Install the angle brackets behind the cross angle pointing towards the towed vehicle.
NOTE: Use the existing bolts just removed but be certain to reverse them so the bolt head is on the back side against the new angle bracket and do not use a flat washer under the bolt head. This will allow clearance for the 1/2" bolt installed in the next step.
3. Using the 1/2 x 1 1/2 bolts and Nylon nuts provided, attach the tower bases to the angle brackets just installed. Orient as shown using the hole closest to the tower base cup. Snug the bolts, but do not tighten at this time.
4. Install your tow bar onto the quick attach brackets and fold it to the stored position to be sure that the tower bases will not interfere, adjust accordingly. The tower bases will work in a wide variety of locations.
5. Set the towers into the tower bases (plastic plugs up) and install the spring lock pins.
6. Assemble the tower clamps to the upper and lower "L" brackets so you have four bracket assemblies, an upper and lower right and an upper and lower left. Be sure to orient the clamps and "L" brackets as shown on page 4. Slide a rubber washer over each of the four dowel pins on the "L" brackets.
7. Slide the four bracket assemblies onto the towers. Snug to keep in place but do not tighten at this time.
NOTE: "L" brackets with short pins with a hole through them are upper brackets.
8. Remove the locking rod and unfold the KarGard. Install the locking rod to keep the KarGard straight. Set the KarGard across the tow bar assembly with the driver side "Hold up pin" of the tow bar inserted through the center hole in the bottom aluminum angle. Slide the upper brackets up until the dowel pins fit through a hole in the upper aluminum angle of the KarGard, and install the two hair pins.
IMPORTANT: Use any holes, but be sure to keep the KarGard centered in front of the towed vehicle.
Snug the upper brackets, but do not tighten at this time. Slide the lower brackets up until the dowel pins fit through the same holes in the lower aluminum angles as used in the upper angles. Snug the lower brackets, but do not tighten at this time.
9. Determine if you need to lower the KarGard to provide maximum protection of your towed vehicle lower valence. If you need to lower it, follow the instructions printed on the template supplied with the KarGard.
10. Once openings are cut, (optional) reinstall the KarGard onto the tow bar hold up pin and KarGard dowel pins (bottom first) and install the hair pins. Slide all mounting brackets and the KarGard down as needed and tighten the mounting brackets.
NOTE: Passenger side of KarGard will rest on the quick attach and the driver side will be slightly raised to keep the KarGard parallel with the tow bar and the ground.
11. Tighten all bolts firmly. Make it a habit to check all fasteners occasionally for tightness.
The manufacturer accepts no responsibility for any damage caused to the KarGard or to the towed or towing vehicle from improper installation of this product.

Be sure to read page 1 where you will find important information about your KarGard, as well as installation and storage instructions for everyday use.

(DUNCAN SELF-ALIGNING TOW BARS)

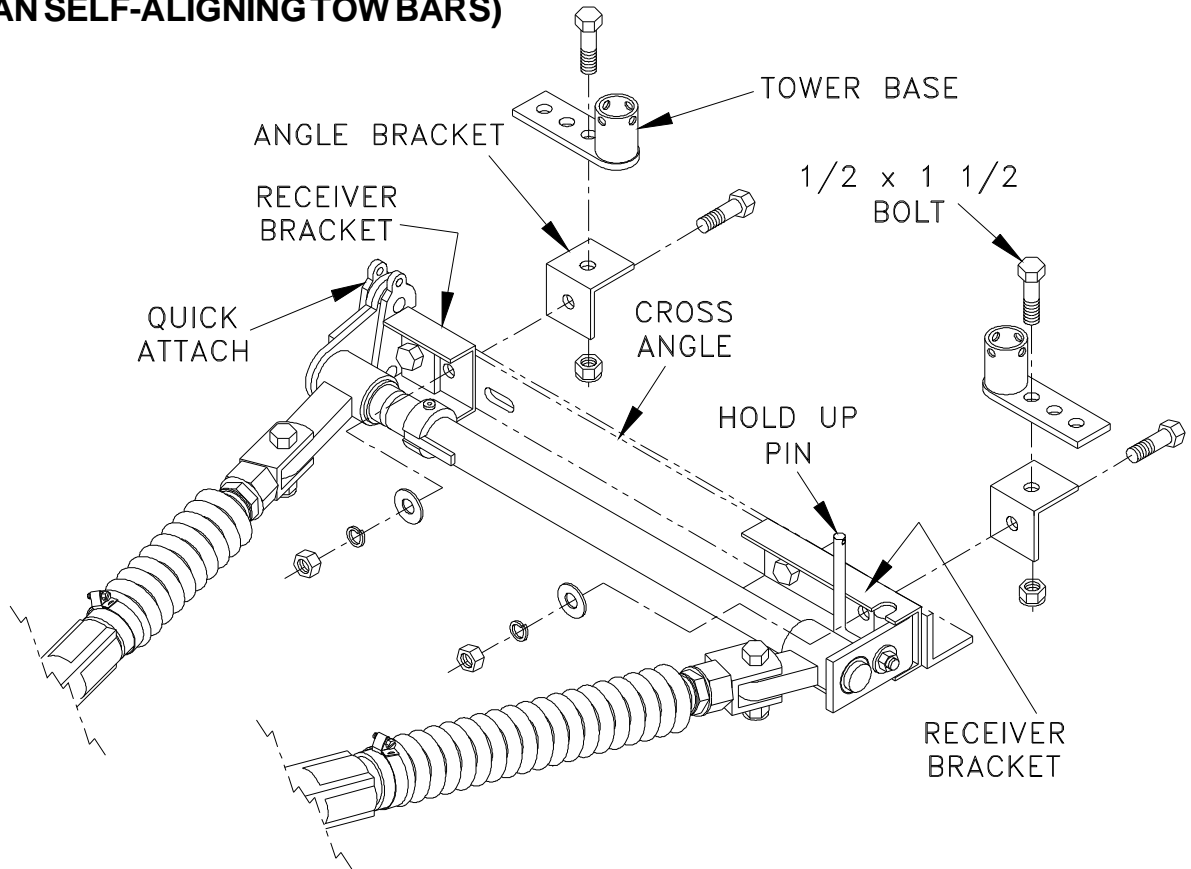

(AVENTA LX, AVENTA II, ALADDIN SELF-ALIGNING TOW BARS)

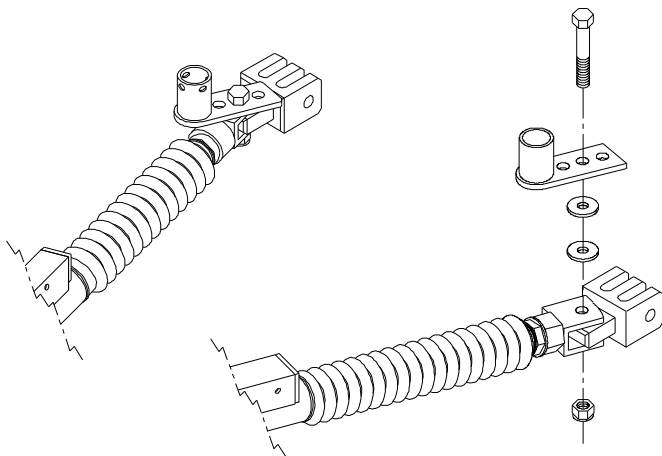

(ADVENTURER ADJUSTABLE TOW BAR)

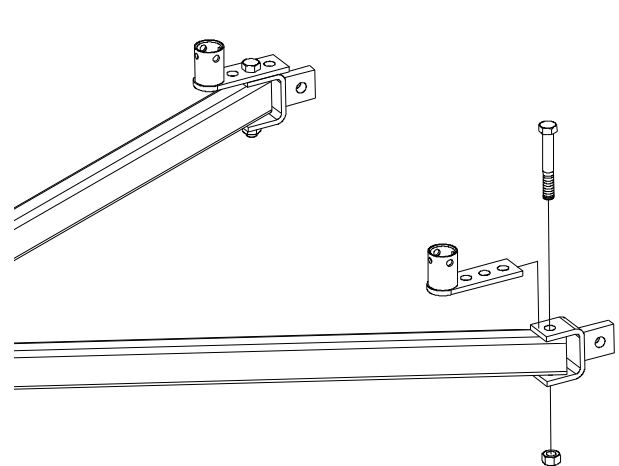

REPLACEMENT PARTS

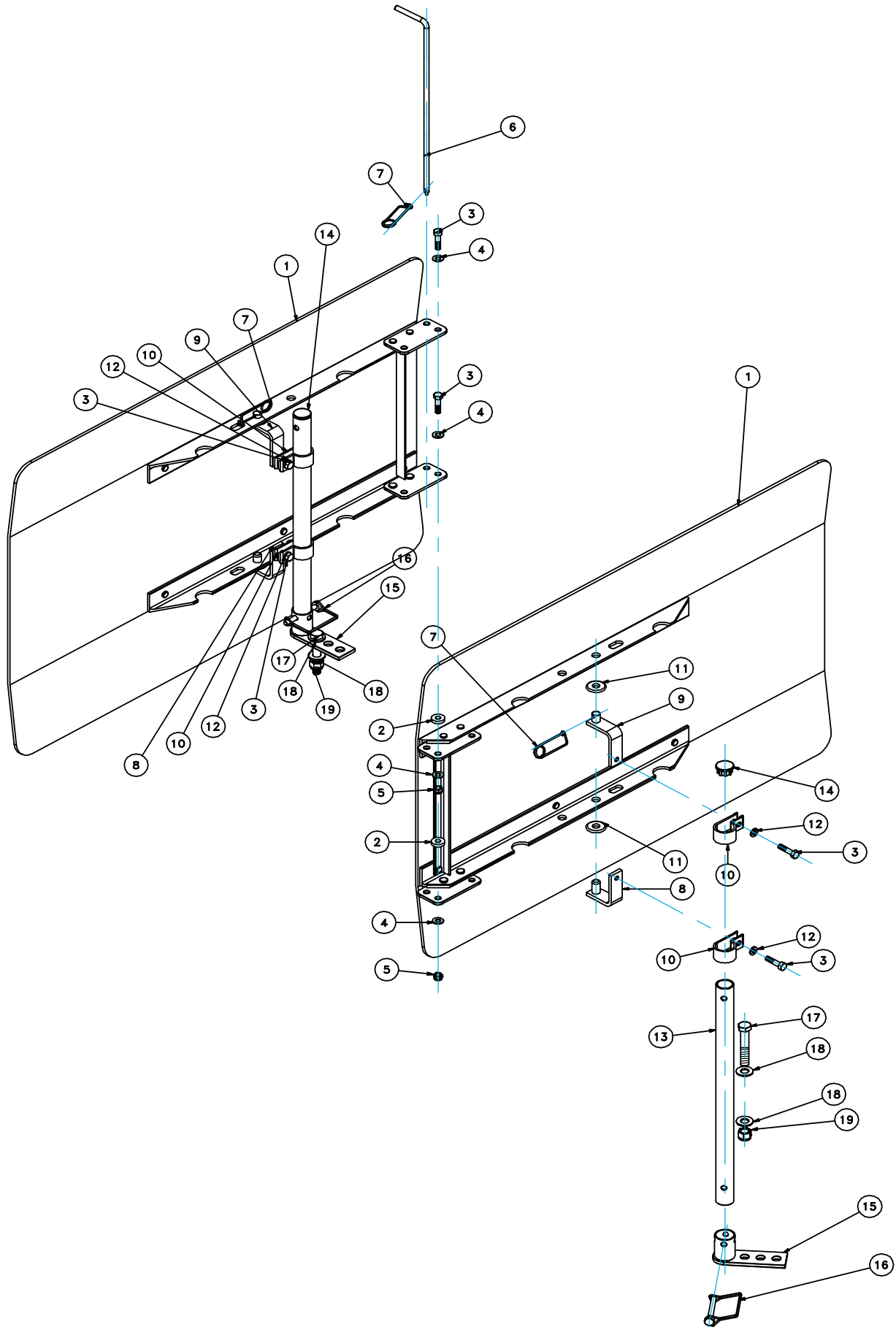

REPLACEMENT PARTS

Parts List

Ref. No.	Qty.	Part No.	Description
1	2	293-1188	Shield Assembly, BX8870, One Side
2	2	290-0357	5/16 x 7/8 Nyatron Washer
3	6	201-0469	5/16-18 x 1 1/4 Hex Head Bolt, Grade 5, ZP
4	4	203-0002	5/16 Flat Washer, ZP
5	2	202-0097	5/16-18 Hex Nylon Insert Lock Nut
6	1	293-1187	Locking Rod, BX8870, Plated
7	3	229-0760	H D Safety Pin .091 x 1-11/16
8	2	293-1184	Lower L Bracket, BX8870, Plated
9	2	293-1185	Upper L Bracket, BX8870, Plated
10	4	293-1183	Tower Clamp, BX8870, Plated
11	4	250-0168	3/8 x 1 1/4 Rubber Washer
12	4	203-0009	5/16 Lock Washer, ZP
13	2	293-1186	Upright Tower, BX8870, Plated
14	2	290-0358	Plastic Cap Plug, Tower, BX8870
15	2	293-1182	Tower Base, BX8870, Plated
16	2	229-0440	5/16 x 2 1/2 Eff. Spring Lock Pin
17	2	201-0490	1/2-13 x 3 Hex Head Bolt, Grade 5, ZP
18	4	203-0005	1/2 Flat Washer, ZP
19	2	202-0094	1/2-13 Hex Nylon Insert Lock Nut
	2	201-0559	3/8-16 x 2.5 x 1.5 x 1.25 U-Bolt, Rnd, ZP (shown on page 11)
	4	201-0051	1/2-13 x 1 1/2 Hex Bolt, Grd. 5, ZP (shown on page 7 and 10)

IMPORTANT: Use only genuine factory replacement parts on your KarGard and Tow Bar. Do not substitute homemade or nontypical parts. If a bolt is lost or in need of replacement, for your safety and the preservation of your equipment, be sure to use a grade 5 replacement bolt.

Repair parts may be ordered through your nearest Automatic dealer or distributor.

REPLACEMENT PARTS

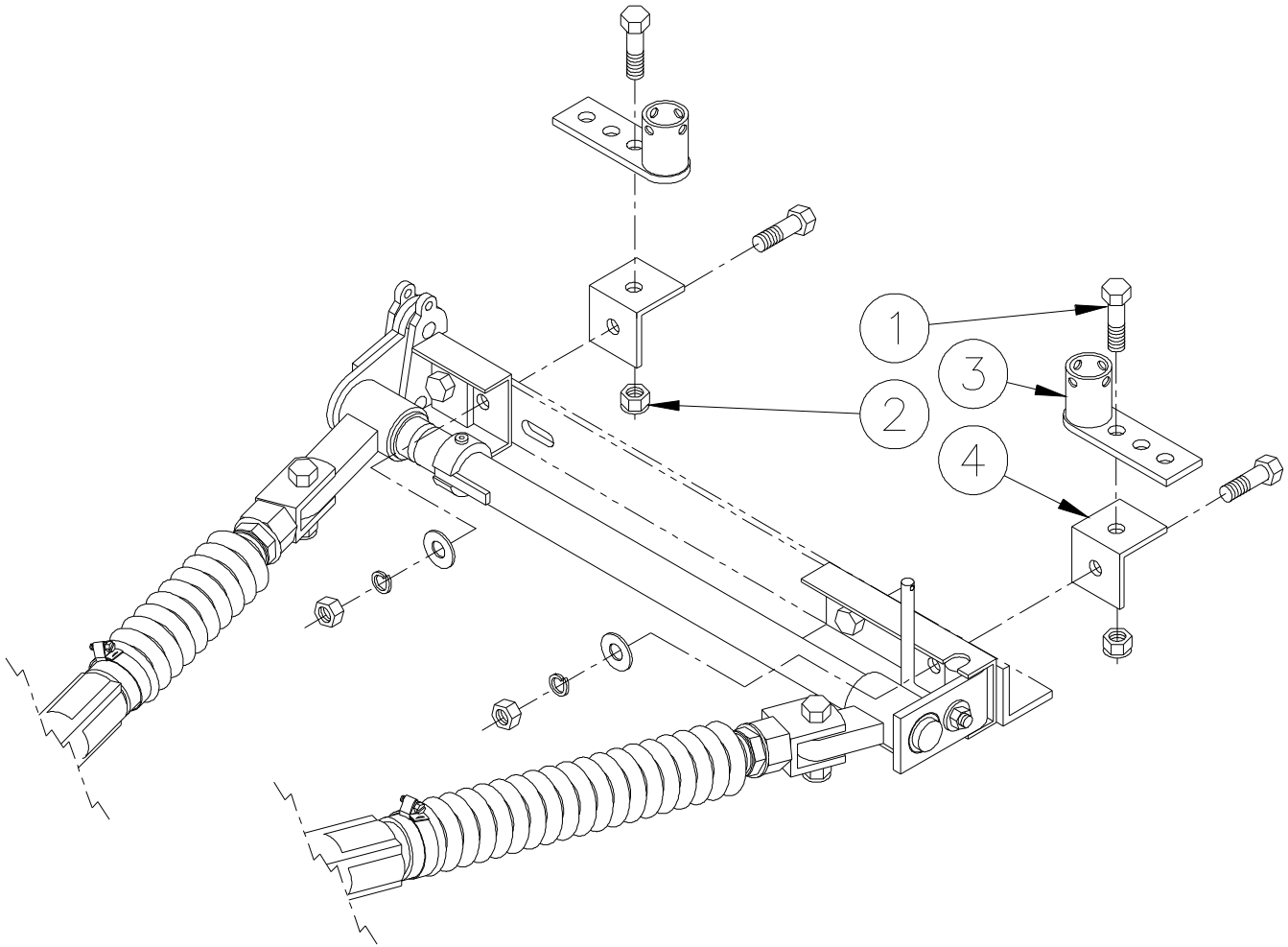

Parts List (Duncan Installation)

Ref. No.	Qty.	Part No.	Description
1	2	201-0051	1/2-13 x 1 1/2 Hex Head Bolt, Grade 5, ZP
2	2	202-0094	1/2-13 Nylon Insert Lock Nut
3	2	293-1182	Tower Base, BX8870, Plated
4	2	293-1189	Angle Bracket, BX8870, Plated, DM

Refer to pages 7-8 for additional Kar Gard parts not shown here

IMPORTANT: Use only genuine factory replacement parts on your KarGard and Tow Bar. Do not substitute homemade or nontypical parts. If a bolt is lost or in need of replacement, for your safety and the preservation of your equipment, be sure to use a grade 5 replacement bolt.

Repair parts may be ordered through your nearest Automatic dealer or distributor.

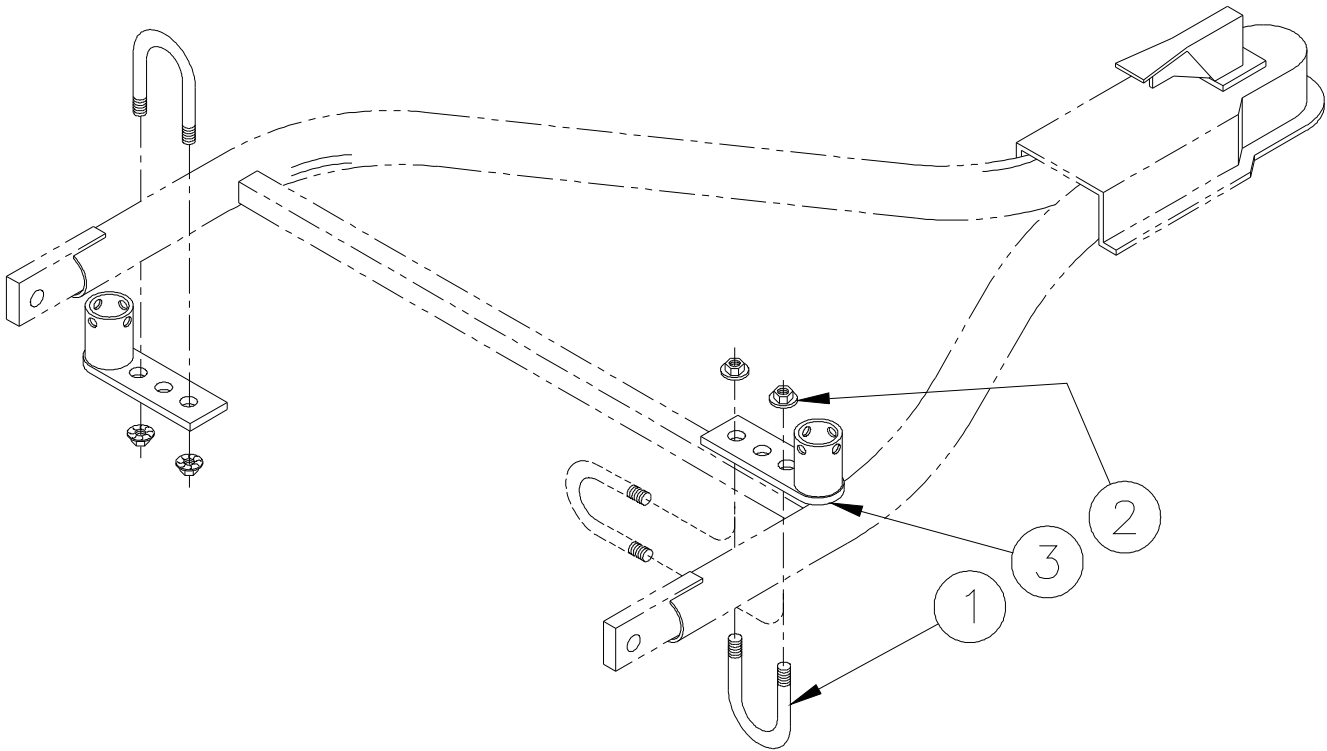

**Parts List
(Tube Type Tow Bars)**

Ref. No.	Qty.	Part No.	Description
1	2	201-0559	3/8-16 x 2 1/2 x 1 1/2 x 1 1/4, U-Bolt, ZP
2	4	202-0071	Hex Flange Whiz Lock Nut, ZP
3	2	293-1182	Tower Base, BX8870, Plated

Refer to pages 7-8 for additional KarGard parts not shown here

IMPORTANT: Use only genuine factory replacement parts on your KarGard and Tow Bar. Do not substitute homemade or nontypical parts. If a bolt is lost or in need of replacement, for your safety and the preservation of your equipment, be sure to use a grade 5 replacement bolt.

Repair parts may be ordered through your nearest Automatic dealer or distributor.



Strong As An Ox™

QUICK REFERENCE GUIDE

INSTALLATION FOR TOWING

1. Remove locking rod, unfold the KarGard and lock it straight with the locking rod.
2. Install the towers into the tower bases. Pin them in place with the spring lock pins.
3. Set the KarGard on the dowel pins (bottom first) then install the hair pins to secure the KarGard in place.
4. The KarGard is installed and ready for towing.

REMOVAL FOR STORAGE

1. Remove the hair pins and lay the KarGard flat. (angles up) Replace hair pins to prevent loss.
2. Remove the towers from the tower bases. Place the spring lock pins in the storage holes to prevent loss.
3. Store tower assemblies in slots in KarGard. Fold the KarGard and insert the locking rod.
4. The locking rod at the hinged end serves as a handle.

BX8870
KARGARD™

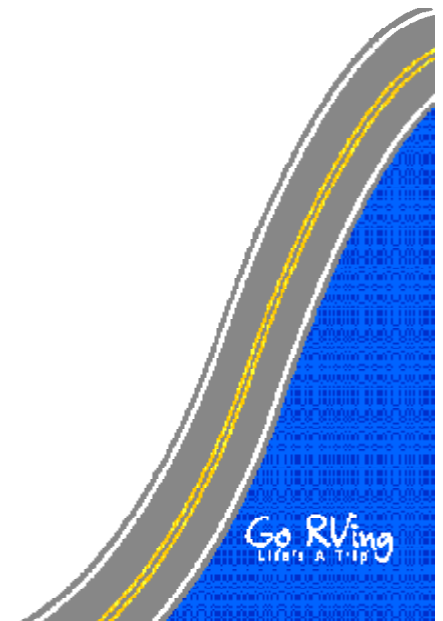

Adjusting The KarGard™ For Maximum Protection.

STEP #1 Determine how far below the tow bar legs the KarGard needs to extend in order to protect the entire front end of the towed vehicle. Maximum adjustment is 5-1/2" down.

STEP #2 Cut out the U-shaped area of the template following the dotted line. Choose which dotted line based on the width of the tow bar leg (or bracketing.)

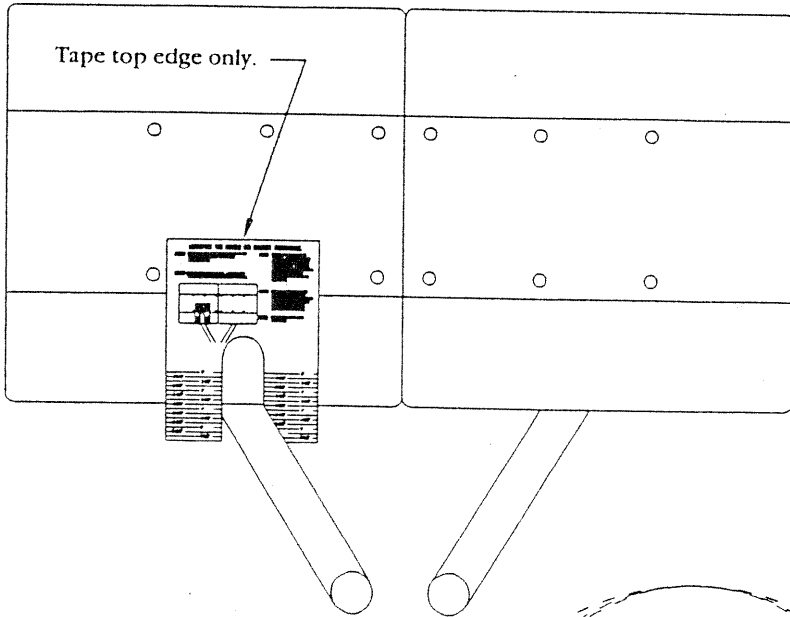

STEP #3 While holding the top edge of the template against the KarGard, and allowing it to hang straight down, center the cut out area of the template on the tow bar leg (or bracketing). Move it down past the bottom edge of the KarGard the number of inches that you wish to lower the KarGard. Tape the template (top edge only) to the KarGard. NOTE: See both illustrations above.

STEP #4 Carefully press the template against the KarGard and mark the KarGard around the cut out area using a marker, chalk, grease pencil, etc. NOTE: You may need to lift up this side (or remove the KarGard) if the tow bar leg interferes with pressing the template flat against the KarGard.

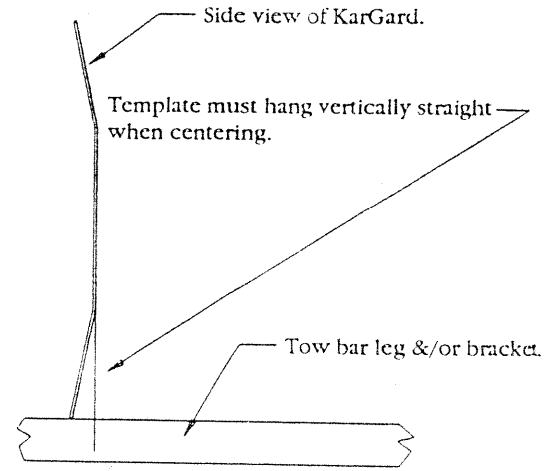

STEP #5 Remove the template and repeat STEP #3 for the other tow bar leg.

STEP #6 Remove the KarGard and cut out the marked areas with a saber (jig) saw.

Return to installation instructions upon completion of step #6

