



Strong As An Ox™

Installation Instructions BX3818 1993-02 Volkswagon Cabrio

The bumper fascia and the grill inserts need to be removed for installing the baseplate. Holes need to be drilled. The fascia and fascia inserts need to be trimmed. Headlights can be removed for ease of installation.

1. Remove the three plastic push rivets connecting the fender well molding and the fascia. Next remove the molded plastic piece held by the torx bolt just inboard of the rivets just removed.
2. Following the fender well molding under the vehicle, remove the two screws on the bottom. Remove the four plastic push rivets from the bottom of the fascia. Next remove the screws to the other side of the fender well molding and the molded plastic piece. Looking up into the fender area, remove a piece oval in shape about 2 by 4 inches. There is one on each side.
3. There are four fascia inserts (plastic grill moldings, including the one with the Volkswagon logo) which need to be pulled out. Be careful to not break a clip on any of the pieces when removing them from the fascia. Once the plastic pieces are off, remove the torx bolts revealed. There will be one torx in the lower openings and five in the main grill area.
4. The bumper fascia can now be pulled off from the vehicle. There are two plastic clips below each fender that the bumper fascia slides and clips into. Be careful while doing this. It is easier to install the wire nuts with the headlights removed. This can be done by removing the torx bolts from the top and the bottom of the headlight assemblies.
5. Position the baseplate (Item 1) so the side pieces are positioned on the outside of the frames behind the metal bumper. Be sure the middle braces extending up to the metal bumper square to bumper, each brace should go to the lower angled section of the bumper. Once the baseplate is lined up properly clamp it to the frame.
6. Center punch one of the side holes and using a 3/8-16 x 1 1/4 bolts (Item 3 and 5) with a lock washer and the 3/8 nut plate (Item 2) with wire. On the top of each frame is a large, black plug. Use this hole to insert the nut plates (Item 2 and 3). Align the nut plates with the hole and thread the bolt into the nut plate, hand tighten. Do the same for the rest of the holes on the side of the frame. **Be sure and use loctite on all bolts before tightening. Tighten all bolts according to the General Instruction sheet.**
7. Drill the 3/8" holes for the middle braces. Use the 3/8" wire nut (Item 2), 3/8-16 x 1 1/4 bolts and lock washers (Items 4 and 5). **Be sure and use loctite on all bolts before tightening. Tighten all bolts according to the General Instruction sheet.**
8. Before replacing the fascia. It is necessary to trim the outside grill pieces for the lower plastic insert to allow the attachment tabs can extend through. Hold the insert to its original position and mark the area where the attachment tabs meet the plastic and trim where needed. It is also necessary to trim the outside plastic inserts so they can be installed. They should only have to be trimmed on the corners to clear the baseplate. If the inserts are not setting in their holding position properly, it may be necessary to pop rivet the outside pieces in place.
9. Replace fascia, the headlight assemblies and the grill.
10. Install the tow bar and safety cables according to the instructions included in their packages.
11. DEALER OR INSTALLER: BE CERTAIN THE USER RECEIVES THE INSTRUCTION SHEET.



Go RVing
THE WAY TO LIVE

Tools Required

10MM Wrench
1/4" Drill Bit

9/16" Socket
3/8" Drill Bit

Loctite Red
Pliers

Phillips Screw Utility Knife
Torx T-25, T-27

Parts List

| Ref. No. | Qty. | Part No. | Description |
|----------|------|----------|-----------------------------------------------|
| 1 | 1 | 61-5399 | Weldment, Baseplate BX3818 |
| 2 | 2 | 61-4978 | 3/8 Wire Nut |
| 3 | 4 | 61-5208 | 3/8 Nut Plate with Wire |
| 4 | 6 | 201-0368 | 3/8-16 x 1 1/4 Hex Bolt, Grade 5 |
| 5 | 6 | 203-0010 | 3/8 Lock Washer |
| 6 | 2 | 201-0979 | #12-14 x 1" Self Drilling Screw, ZP |
| 7 | 2 | 202-0047 | #10-32 Hex Nut |
| 8 | 2 | 203-0054 | #10 Lock Washer |
| 9 | 2 | 101-5822 | Adapter, 4 Way Connector |
| 10 | 2 | 201-0192 | #10-32 x 1/2 Screw |
| | 2 | 226-0046 | Baseplate Safety Cable 36" CL III (Not Shown) |
| | 4 | 229-0359 | Quicklink, 3/8, ZP (Not Shown) |
| | 2 | 229-0536 | 6.3MM Plastic Rivets (Not Shown) |

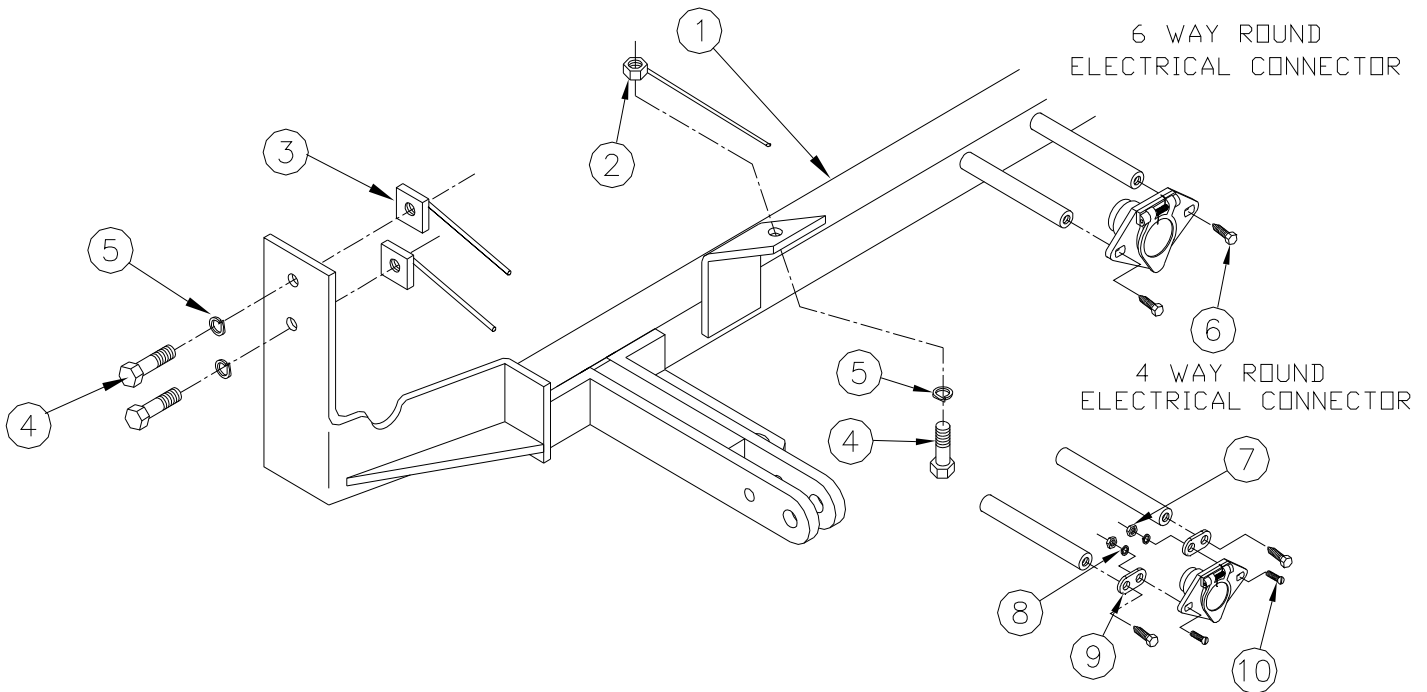

General Information

1. It is the owner's responsibility to inspect all towing equipment for cracked welds, missing or worn parts and loose bolts before each towing trip. Be sure to use Loctite® Red on all bolts and tighten to the recommended specifications.
2. It is the owner's responsibility to hook up all towing equipment per manufacturer's instructions/ recommendations.
3. Remove the attachment tabs when not in use (if applicable).

Notice To Baseplate Installer

1. It is YOUR responsibility to watch for:

- Oil cooler and air conditioner lines
- Electrical wires and hoses
- Missing parts or attaching points on the frame

** If the baseplate is improperly installed and is against a wire or hose, it could cause fluid leaks or electrical shorts some time after the actual baseplate installation.

Permanent Baseplate Safety Cable Installation

Permanent baseplate safety cables are strongly recommended when towing a vehicle with a tow bar. The principle function of the permanent baseplate safety cables is to prevent the towed vehicle from breaking loose in the event the connection between the frame of the towed vehicle and the baseplate fails or becomes disconnected. The cables must be connected from the baseplate to the frame rail or cross member of the vehicle's frame. The illustrations below show the possible arrangements recommended by Blue Ox®. Each permanent baseplate safety cable must have an adequate weight rating for the towing system. The weight rating of the two (2) cables together will not qualify.

Do not mount the permanent baseplate safety cables against wires, hoses or brake lines.

These permanent baseplate safety cables should remain installed as long as the baseplate is installed on the vehicle. Permanent baseplate safety cables are to be used in conjunction with, and NOT a replacement for legally required safety cables attaching the towed vehicle to the towing vehicle.

OPTION #1

Permanent Baseplate Safety Cables to Cross Member or Frame of Towed Vehicle.

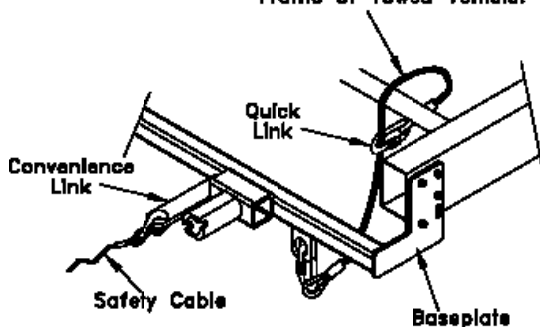

OPTION #2

Permanent Baseplate Safety Cables to Cross Member or Frame of Towed Vehicle.

