



BX3770

2006-12 Toyota RAV4 (Includes Sport/Limited) Installation Instructions

Attachment Tab Height: 24"

Attachment Tab Width: 22"

Please read BOTH these Installation Instructions and the General Instructions prior to installing or operating this equipment.

1. Blue Ox® towing products and accessories are intended to be installed by Blue Ox® Dealers who are familiar with our products and have the equipment and knowledge necessary to do "it work".
2. Many Blue Ox® baseplates are designed to use existing holes and hardware to mount the baseplate to the towed vehicle. Even though bolts are there, do not assume they are adequate for baseplate mounting. Always use the hardware supplied in the hardware kit and existing hardware as specified in the installation instructions.

Bolt Torque Specifications
Torque in Foot-Pounds for Metric Bolts

Bolt Size	Grade 8.8	Grade 10.9
6MM	6	8
8MM	16	22
10MM	31	40
12MM	54	70
14MM	89	117



Bolt Torque Specifications
Torque in Foot-Pounds for Inch Bolts

Bolt Size	Grade 5	Grade 8
1/4"	10	14
5/16"	19	29
3/8"	33	47
7/16"	54	78
1/2"	78	119
5/8"	154	230

Reference your vehicle owner's manual for manufacturer's towing specifications.

! WARNING

Failure to read and follow these instructions could result in separation of the towed vehicle from the tow bar, causing property damage, loss of towed vehicle, personal injury or death.

BX3770
2006-12 Toyota RAV4 (Includes Sport/Limited)
Installation Instructions

Instruction Notes: The fascia, radiator cover, belly pan, air baffle, horns, styrofoam supports and windshield washer fluid reservoir are removed and reinstalled for the baseplate installation. Some drilling and trimming is required.

Place all components that are removed on a flat, sturdy surface. All items will be reinstalled unless otherwise noted after the baseplate is installed.

The dimensional variations between otherwise identical vehicles can be considerable. While the baseplate was designed for easy installation, it may be necessary to tailor the baseplate slightly to compensate for vehicle manufacturer's tolerances.

The BX8848 4-Diode Wiring Kit is recommended for this vehicle.

NOTICE

- Handling of some cosmetic parts when installing this product may require the use of protective covers, rags, specialty tools, etc. to prevent damage.
- When using power drills be aware of the dangers of torque and drill bit length.
- When using a reciprocating saw be aware of objects behind the cutting surface.
- Use a good quality paint to spray cut edges of frame to prevent rusting.
- Be sure that **ALL** electrical connections are plugged in and accessories are functioning properly before reinstalling the fascia.
- Do not use the towed vehicle for storing luggage, equipment, etc. This may cause you to exceed the towing capacity of the tow bar, baseplate and its accessories.
- Be sure to use Loctite® Red on all bolts before tightening. Tighten all bolts according to the torque chart provided.
- Dealer or installer be certain the user receives these instruction sheet.
- If the baseplate is in an accident, it must be replaced. **DO NOT** use it again! An accident can cause unseen damage and using it again could result in more damage or serious injury. **DO NOT** use the baseplate if it is damaged or missing parts.

BX3770
2006-12 Toyota RAV4 (Includes Sport/Limited)
Installation Instructions

Tools Required

Large Vise Grip
 Flat Screwdriver
 Utility Knife
 Reciprocating Saw
 Torque Wrench
 Drill
 Tape Measure
 Loctite® RED
 13/32" Carbide Drill Bit
 3/4" Socket
 9/16" Socket
 9/16" Wrench

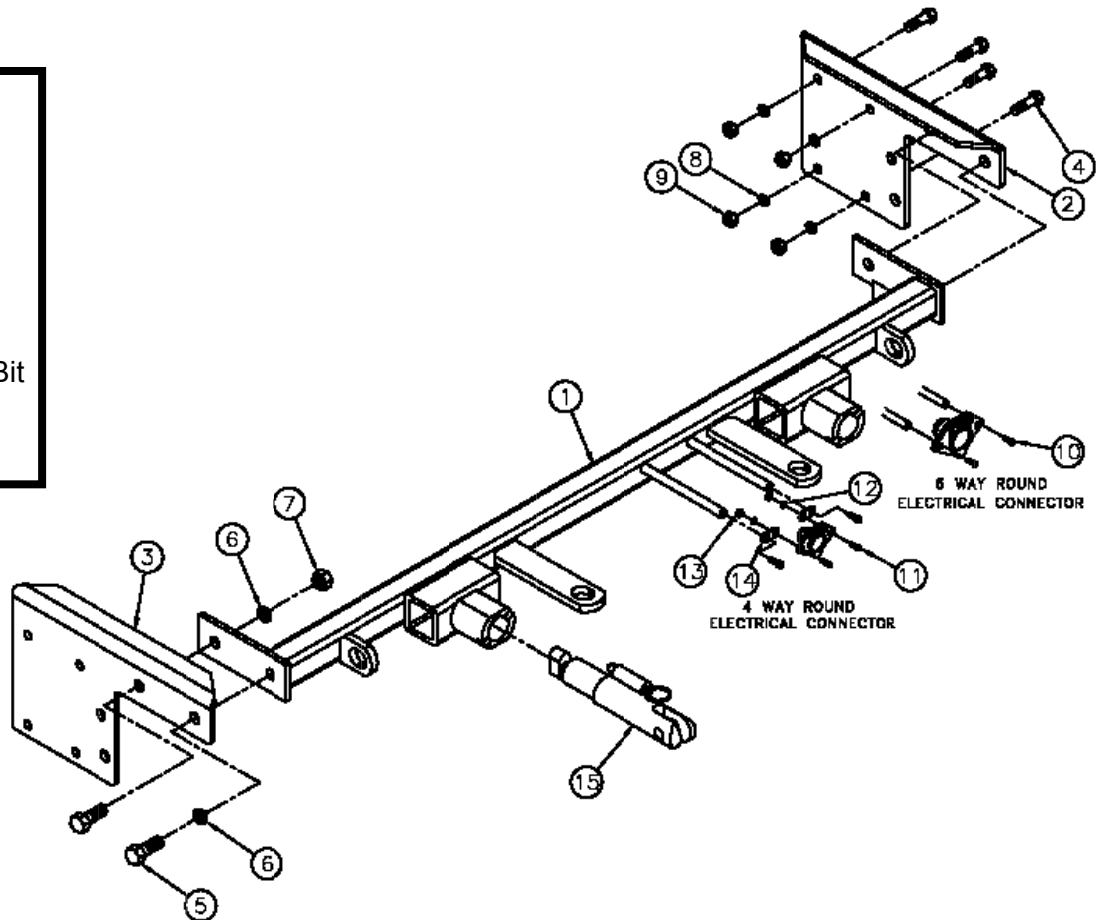

Item No.	Part No.	Description	Qty.
1.....	61-6297	BX3770 Baseplate Crosstube	1
2.....	101-6979	BX3770 End Plate, DS	1
3.....	101-6980	BX3770 End Plate, PS	1
4.....	201-0443	3/8"-16 x 1" Hex Head Bolt, Grade 5, ZP	8
5.....	201-0011	1/2"-13 x 1-1/4" Hex Head Bolt, Grade 5, ZP	4
6.....	203-0012	1/2" Lock Washer	4
7.....	202-0005	1/2"-13 Hex Nut, ZP.....	2
8.....	203-0010	3/8" Lock Washer, ZP	6
9.....	202-0003	3/8"-16 Hex Nut, ZP.....	8
10.....	201-0979	#12-14 x 1" Self Drilling Screw, ZP.....	2
11.....	201-0192	#10-32 x 1/2" Slot Head Screw	2
12.....	203-0054	#10 Lock Washer, ZP	2
13.....	202-0047	#10-32 Hex Nut, ZP.....	2
14.....	101-5822	4 Way Connector Adapter	2
15.....	62-3468	Attachment Tab Assembly	2
16.....	226-0046(not shown)	Class III Safety Cables	2
17.....	229-0359(not shown)	3/8" Quicklink, ZP	2
18.....	290-0437(not shown)	Black Cap Plug Receiver.....	2

Important:

Use only genuine factory replacement parts on your baseplate. Do **NOT** substitute homemade or non-typical parts. If a bolt is lost or in need of replacement, for your safety and the preservation of your baseplate, be sure to use a replacement bolt of the same grade (In most cases it will be Grade 5, please reference the parts list above). Replacement parts may be ordered through your nearest Blue Ox® Dealer or Distributor. Failing to follow and/or altering these installation instructions in either installation or required equipment will void the manufacturer's warranty.

BX3770
2006-12 Toyota RAV4 (Includes Sport/Limited)
Installation Instructions



1. Remove four (4) push pins from the radiator cover (gray). Repeat on the other side of the vehicle. In the center of the radiator cover, remove one (1) push pin (white) and remove the cover from the vehicle.



2. Remove the two (2) corner push pins (gray). Then above the grill remove the two (2) inner push pins (white).



3. On the outer edge of the wheel well, turn the screw 90 degrees (right). Some models will have two (2) additional screws to remove using a 10MM socket (left). Repeat on the other side of the vehicle.



4. Behind the wheel well cover at the top of the fascia, using a 10MM socket remove the one (1) screw. Repeat on the other side of the vehicle.

BX3770
2006-12 Toyota RAV4 (Includes Sport/Limited)
Installation Instructions

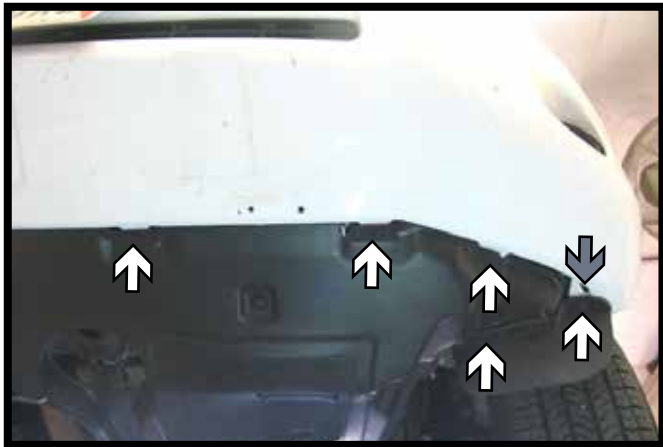

5. On the underside of the fascia, using a 10MM socket, remove five (5) screws. Some models may have an additional push pin to remove (gray). Repeat on the other side of the vehicle.

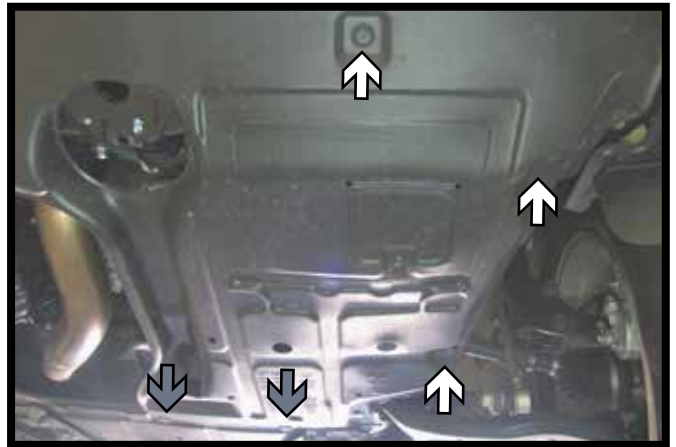

6. On the bellypan, remove the three (3) drivers side push pins (white). Repeat on the passenger side. Located towards the rear of the belly pan remove the two (2) push pins (gray). Set the pan aside and carefully remove the fascia from the vehicle.



7. On the driver side, using a 10MM socket, remove the two (2) bolts from the air baffle. Also the if equipped the upper bolt (gray) will need to be removed to free the air baffle tube from the vehicle.



8. On the passenger side, disconnect the electrical connections from the washer reservoir. Disconnect and plug the fluid lines. Using a 10MM socket, remove the bolt from the rear of the reservoir.

BX3770
2006-12 Toyota RAV4 (Includes Sport/Limited)
Installation Instructions

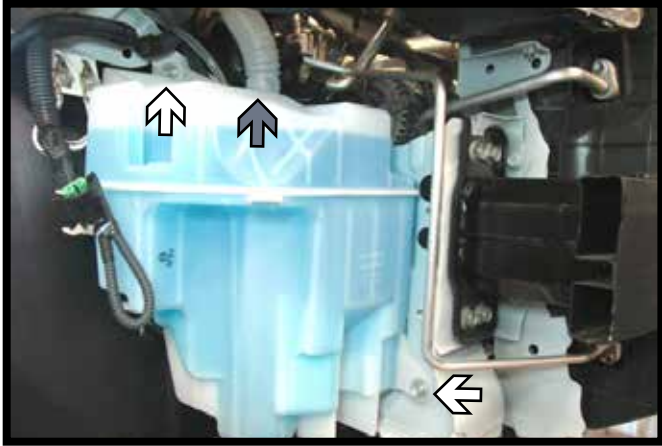

9. On the front side of the reservoir, disconnect the fill tube (gray). Using a 10MM socket, remove the front and top bolts (white) and set the reservoir aside.

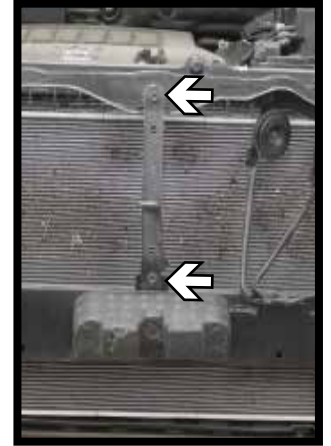

10. Depending on model, use a 10MM socket, remove the bolt(s) from the fascia support. Remove the support and the styrofoam supports around it.



11. Disconnect the electrical connection from the both horns. Move the wiring aside to clear the baseplate installation.



12. On the air deflectors on either side of the vehicle, measure a 4-1/4" deep x 3" high section with the bottom flush with the bumper. Trim these areas out for baseplate clearance.

BX3770
2006-12 Toyota RAV4 (Includes Sport/Limited)
Installation Instructions



13. Measure and mark an area 1-1/2" down from the top of the frame and flush with the frame rail. Using a reciprocating saw notch the frame and bumper bracket. Do this on both sides of the vehicle.

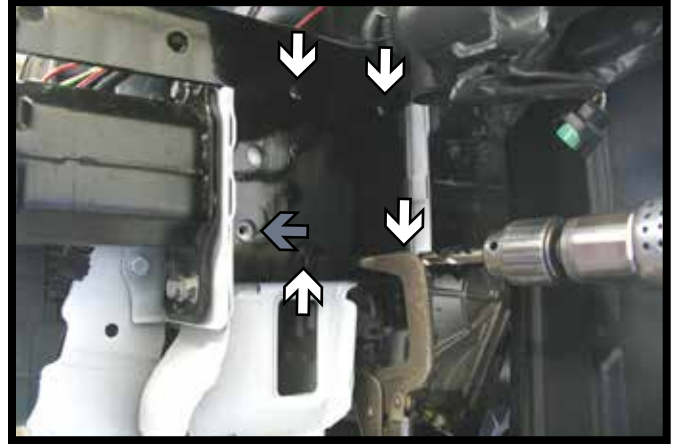

14. Align the bottom of the endplate flush with the bottom of the frame. Align the existing hole (gray) to the baseplate hole and clamp the endplate. Using a 13/32" drill bit, drill the four (4) holes into the frame (white). Do this on both sides of the vehicle.



15. Dry fit the four (4) holes with 3/8"-16 x 1" bolts, 3/8" lock washers and 3/8"-16 nuts, using the hole in the frame opening. Hand tighten bolts for now, these bolts will be torqued after the crosstube is installed. Do this on both sides of the vehicle.



16. Install the crosstube onto the endplates, with a 1/2"-13 x 1-1/4" bolt and 1/2" lock washer in the front holes (white). Then a 1/2"-13 x 1-1/4" bolt, 1/2" lock washer and 1/2"-13 nut on the rear holes (gray). Reinstall the 3/8"-16 bolts with Locite® and torque all bolts to specifications.

BX3770
2006-12 Toyota RAV4 (Includes Sport/Limited)
Installation Instructions



17. Attach the permanent baseplate safety cables to the provided convenience link on the baseplate. The photo above shows the recommended installation of the cables to frame of vehicle. Additional options may interfere with suggested mounting; in this case, secure the cables to a solid piece of the frame as described in the instructions included with the permanent baseplate safety cables. Be sure the safety cables do not rub against any hoses or moving parts. Do this on **BOTH** sides of the vehicle.

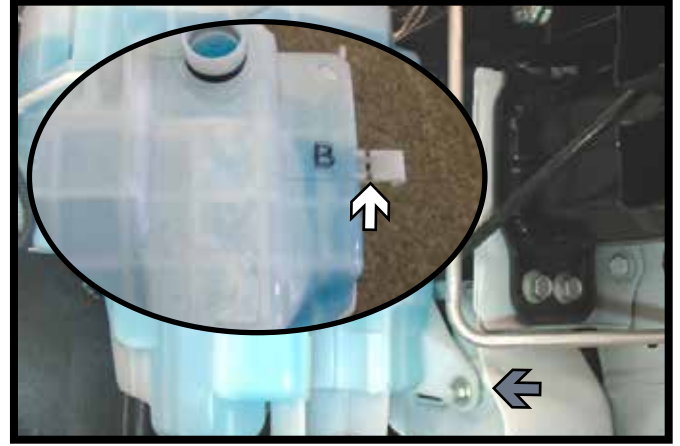

18. Prior to reinstalling the washer reservoir, trim the tab from the backside as shown above (white). When reinstalling the reservoir use three (3) 1/4" flat washers between the reservoir and frame as a spacer on the front bolt (gray).

Reinstall the fascia support bracket and styrofoam supports.



19. Reinstall the air baffle.



20. Hold fascia up to vehicle as close to it's original position. Mark and trim the fascia for clearance of the attachment tabs and convenience links. Reinstall the fascia, belly pan and radiator cover.

BX3770
2006-12 Toyota RAV4 (Includes Sport/Limited)
Installation Instructions



General Information

1. It is the owner's responsibility to inspect all towing equipment for cracked welds, missing or worn parts and loose bolts before each towing trip. Be sure to use Loctite® Red on all bolts and tighten to the recommended specifications.
2. It is the owner's responsibility to hook up all towing equipment per manufacturer's instructions/ recommendations.
3. Remove the attachment tabs when not in use (if applicable).

Notice To Baseplate Installer

1. It is YOUR responsibility to watch for:

- Oil cooler and air conditioner lines
- Electrical wires and hoses
- Missing parts or attaching points on the frame

** If the baseplate is improperly installed and is against a wire or hose, it could cause fluid leaks or electrical shorts some time after the actual baseplate installation.

Permanent Baseplate Safety Cable Installation

Permanent baseplate safety cables are strongly recommended when towing a vehicle with a tow bar. The principle function of the permanent baseplate safety cables is to prevent the towed vehicle from breaking loose in the event the connection between the frame of the towed vehicle and the baseplate fails or becomes disconnected. The cables must be connected from the baseplate to the frame rail or cross member of the vehicle's frame. The illustrations below show the possible arrangements recommended by Blue Ox®. Each permanent baseplate safety cable must have an adequate weight rating for the towing system. The weight rating of the two (2) cables together will not qualify.

Do not mount the permanent baseplate safety cables against wires, hoses or brake lines.

These permanent baseplate safety cables should remain installed as long as the baseplate is installed on the vehicle. Permanent baseplate safety cables are to be used in conjunction with, and NOT a replacement for legally required safety cables attaching the towed vehicle to the towing vehicle.

OPTION #1

Permanent Baseplate Safety Cables to Cross Member or Frame of Towed Vehicle.

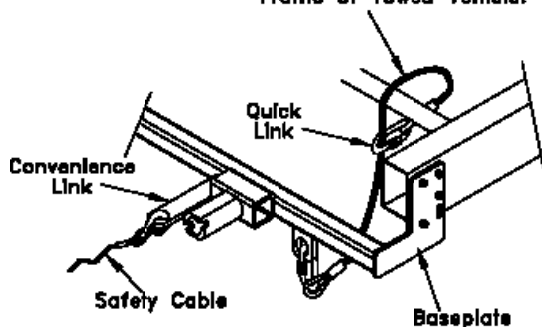

OPTION #2

Permanent Baseplate Safety Cables to Cross Member or Frame of Towed Vehicle.

