



Baseplate Installation Instructions

BX3759

2005-07 Toyota Matrix 2005-07 Toyota Matrix XRS 2007 Toyota Corolla S 2008 Toyota Matrix Installation Instructions

Please read **BOTH** these Installation Instructions and the General Towing Instructions before attempting to install or operate this equipment.

1. Blue Ox® towing products and accessories are intended to be installed by Blue Ox® Dealers who are familiar with our products and have the equipment and knowledge to do “fit work.”
2. Many Blue Ox® Baseplates are designed to use existing holes and hardware to mount the baseplate to the towed vehicle. Even though bolts are there, do not assume they are adequate for baseplate mounting. Always use hardware supplied in the hardware kit or existing hardware specified in the Baseplate Towing Installation Instructions.

Confirm the towability and pre-towing procedures for your vehicle with the owner’s manual or contact the vehicle’s manufacturer for specific towing procedures.

Attachment Tab Height: 14.5”

Attachment Tab Width: 24”

Bolt Torque Specifications

Torque in Foot-Pounds per Metric Bolts

Bolt Size	Grade 8.8	Grade 10.9
6MM	6	8
8MM	16	22
10MM	31	40
12MM	54	70
14MM	89	117

Bolt Torque Specifications

Torque in Foot-Pounds per Inch Bolts

Bolt Size	Grade 5	Grade 8
1/4”	10	14
5/16”	19	29
3/8”	33	47
7/16”	54	78
1/2”	78	119
5/8”	154	230

WARNING

Failure to read and follow these instructions could result in separation of the towed vehicle from the tow bar, causing property damage, loss of towed vehicle, personal injury or death.

BX3759

2005-08 Toyota Matrix

2005-07 Toyota Matrix XRS

2007 Toyota Corolla S

Installation Instructions

Parts List

Ref. No.	Qty.	Part #	Description
1	1	61-6036	Weldment, Baseplate, BX3759
2	4	61-5338	1/2" Nut Plate, 10" wire
3	4	61-5208	3/8" Nut Plate, 14" wire
4	4	201-0051	1/2-13 x 1 1/2 Bolt, GRD. 5, ZP
5	4	203-0012	1/2" Lock Washer, ZP
6	4	201-0440	3/8-16 x 1 1/2 Bolt, GRD. 5, ZP
7	4	203-0010	3/8" Lock Washer, ZP
8	2	201-0979	#12-14 x 1" Self Drilling Screw, ZP
9	2	201-0192	#10-32 x 1/2 Slot, RD. HD. Screw
10	2	203-0054	#10 Lock Washer
11	2	202-0047	#10-32 Hex Nut
12	2	101-5822	Adapter, 4 Way Connector
13	2	62-3468	Attachment, Assembly, SF/SB (R)
	2	226-0046	Baseplate Safety Cable, 36" CL III (Not Shown)
	2	229-0359	Quicklink, 3/8, ZP (Not Shown)
	2	290-0437	Receiver, Cap Plug (BLK) (Not Shown)"

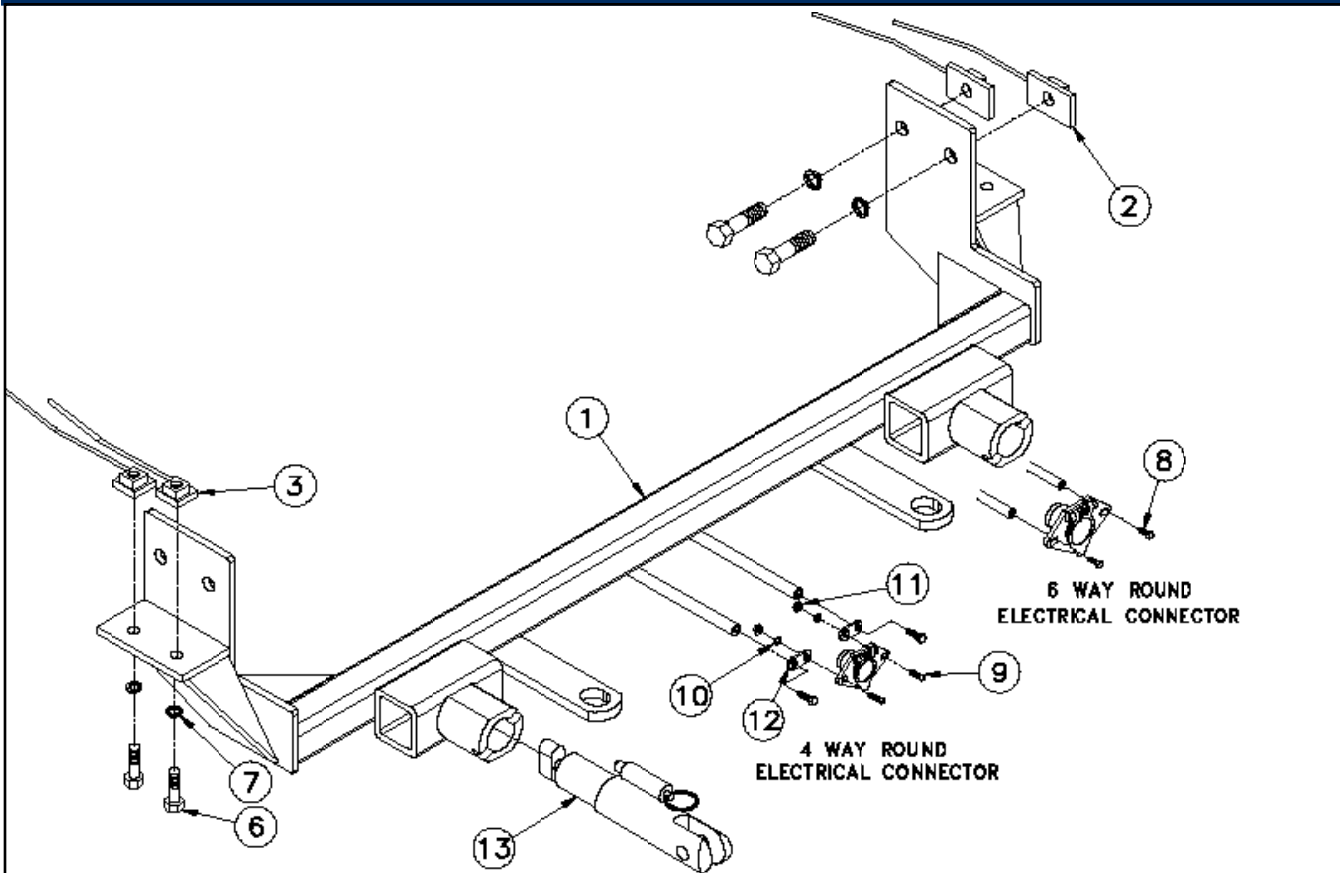

Important:

Use only genuine factory replacement parts on your baseplate. Do **NOT** substitute homemade or non-typical parts. If a bolt is lost or in need of replacement, for your safety and the preservation of your baseplate, be sure to use a replacement bolt of the same grade (In most cases it will be Grade 5, please reference the parts list above). Replacement parts may be ordered through your nearest Blue Ox® Dealer or Distributor.

BX3759

2005-08 Toyota Matrix 2005-07 Toyota Matrix XRS 2007 Toyota Corolla S Installation Instructions

Vehicle Weight:

The weight of this vehicle is near the Class III, 5,000 lb. rating limitations. Some models, depending on options, may well exceed this 5,000 lb. rating. Be sure to confirm the weight of your individual vehicle before towing. As of 1999, the Aventa® II is now 10,000 lbs. and either the Aventa® II or the Aventa® LX tow bar must be used for these applications.

Tow Bar Adapters are NOT to be used with vehicles weighing over 5,000 lbs.

Installation Notes: The fascia metal bumper and air baffle are removed and reinstalled during installation of the baseplate. Drilling is required. Trimming of the fascia is required.

The dimensional variations between otherwise identical vehicles can be considerable. While the baseplate was designed for easy installation, it may be necessary to tailor the baseplate slightly to compensate for auto manufacturer's tolerances. These minor adjustments may include filing a hole slightly, bending electrical rods and/ or bending end plates.

The BX8869 Bulb and Socket Wiring Kit is recommended for this vehicle.

Installation Instructions:



1. **2005-07 MODELS:** Using the Phillips screw driver, remove the Phillips screw from rubber bumper, do this to both sides and set rubber bumper aside for later reinstallation.



2. **2005-07 MODELS:** Remove push pin from top edge of fascia just below hood latch and set aside for reinstallation later.



3. **2008 MATRIX:** Using the Phillips screw driver, remove the Phillips screw from the top of the fascia outer edge, both sides. Also remove the push pin from the center (gray arrow).

BX3759

2005-08 Toyota Matrix
2005-07 Toyota Matrix XRS

2007 Toyota Corolla S

Installation Instructions

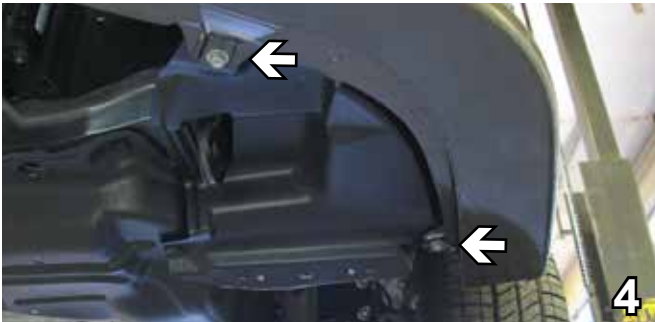

4. **ALL MODELS:** Using a 10MM socket, remove two metric bolts just forward of front tire. Do this to both sides and set aside bolts for later reinstallation.



5. **2005-07 MODELS:** Behind fascia on bottom of metal bumper, are two push pins to remove from fascia's tabs. Remove with flat screw driver and set aside for later reinstallation.



6. **2008 MATRIX:** Underneath the bumper, remove two push pins with a flat screw driver. Set aside for later reinstallation.



7. **ALL MODELS:** Remove metric bolt just forward the front tire on upper corner of fascia and inside of wheel well, using a 10MM socket. Do this to both sides. Pull fascia forward, unplug electrical connection to fog lights, and carefully set aside for reinstallation later.

8. **ALL MODELS:** Remove wire loom from the top of metal bumper with flat screw driver and tie loom up to open area for baseplate installation.



BX3759

2005-08 Toyota Matrix
2005-07 Toyota Matrix XRS
2007 Toyota Corolla S
Installation Instructions



9. **ALL MODELS:** Using a 14MM socket, remove four metric bolts from metal bumper and set aside for later reinstallation.

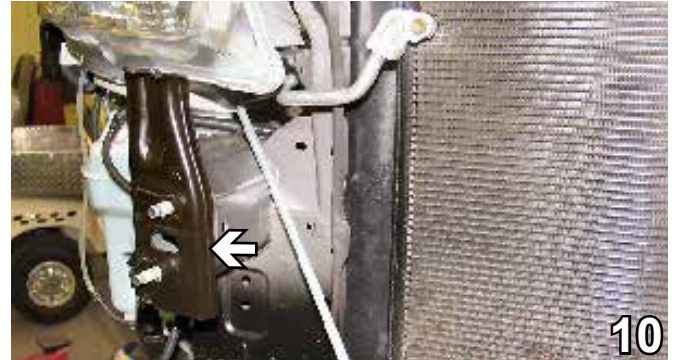

10. **ALL MODELS:** Remove bumper bracket from both sides and set aside.



11. **ALL MODELS:** Drill a hole in the frame rail using the 1 1/4" hole saw on both sides. This hole will allow installer to insert nut plates inside of frame rail in steps 13 and 14.



12. **ALL MODELS:** Slide baseplate up between frame rails to align with existing hole and clamp to the bottom of frame with vise grips on both sides.

NOTE: The existing hole in frame rail may not line up exactly with hole in baseplate because of vehicle variations. Be sure to align holes as close as possible on both sides.

BX3759

2005-08 Toyota Matrix 2005-07 Toyota Matrix XRS 2007 Toyota Corolla S Installation Instructions



13. **ALL MODELS:** Using the baseplate as a template, drill both holes in the side of frame rail with a 17/32" drill bit. Do this to both sides. Insert nut plates into 1 1/4" drilled hole on outer side of frame rail to align with drilled holes. Tighten the 1/2" hex bolts and lock washer with the 3/4" socket into nut plates. Do this to both sides.

NOTE: Be aware of coolant line on passenger's side when drilling. Slide a short piece of pipe or deep well socket over drill bit to protect coolant line.



14. **ALL MODELS:** Using the baseplate as a template, drill two holes into bottom of frame with 13/32" drill bit, both sides. Insert nut plates into 1 1/4" hole on frame rail to align with drilled holes, tighten 3/8" hex bolts and lock washer with 9/16" socket on both sides.

BE SURE TO USE LOCTITE® RED ON ALL BOLTS BEFORE TIGHTENING. TIGHTEN ALL BOLTS ACCORDING TO THE TORQUE CHART ON THE FRONT PAGE OF THESE INSTRUCTIONS OR ON PAGE 3 OF THE BASEPLATE TOWING GENERAL INSTRUCTIONS.



15. **ALL MODELS:** Reinstall bumper bracket, metal bumper and styrofoam. Be sure to reattach wire loom to top of bumper.



16. **2005-07 MODELS:** Hold fascia as close to its original position as possible, mark and cut grill with utility knife to allow baseplate receivers to come through. Plug in fog lights in applicable on back side of fascia and reinstall fascia.

BX3759

2005-08 Toyota Matrix
2005-07 Toyota Matrix XRS
2007 Toyota Corolla S

Installation Instructions



17. **2008 MATRIX:** Attach the permanent baseplate safety cables to a solid piece of the vehicle's frame as in above photos or as close to as possible.



18A. **2008 MATRIX:** On the inside of the fascia, using the utility knife trim off the tab as shown. Do this on both sides.

Be sure that **ALL** electrical connections are plugged in properly and functioning **BEFORE** installing the fascia.



18B. **2008 MATRIX:** Trim the fascia as needed for the baseplate receivers to come through.

BX8869 Bulb and Socket Kits on each vehicle.

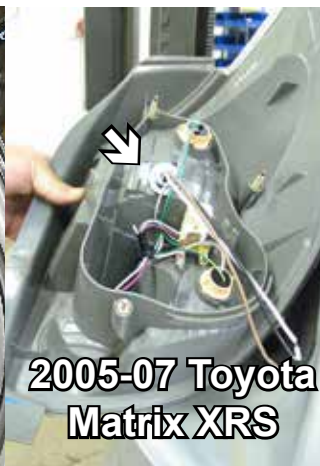

BX3759

2005-08 Toyota Matrix
2005-07 Toyota Matrix XRS

2007 Toyota Corolla S

Installation Instructions



2007 Toyota Corolla S

Install the tow bar and safety cables according to the instructions provided in their packages. When demonstrating this to the customer, be sure to include all the contents and packages.

Do **NOT** substitute other devices if the tow bar pins and clips are misplaced.

DEALER or INSTALLER:
Be certain the user receives the instruction sheets for their products.



2005-07 Toyota Matrix



2005-07 Toyota Matrix XRS



2008 Toyota Matrix



General Information

1. It is the owner's responsibility to inspect all towing equipment for cracked welds, missing or worn parts and loose bolts before each towing trip. Be sure to use Loctite® Red on all bolts and tighten to the recommended specifications.
2. It is the owner's responsibility to hook up all towing equipment per manufacturer's instructions/recommendations.
3. Remove the attachment tabs when not in use (if applicable).

Notice To Baseplate Installer

1. It is YOUR responsibility to watch for:

- Oil cooler and air conditioner lines
- Electrical wires and hoses
- Missing parts or attaching points on the frame

** If the baseplate is improperly installed and is against a wire or hose, it could cause fluid leaks or electrical shorts some time after the actual baseplate installation.

Permanent Baseplate Safety Cable Installation

Permanent baseplate safety cables are strongly recommended when towing a vehicle with a tow bar. The principle function of the permanent baseplate safety cables is to prevent the towed vehicle from breaking loose in the event the connection between the frame of the towed vehicle and the baseplate fails or becomes disconnected. The cables must be connected from the baseplate to the frame rail or cross member of the vehicle's frame. The illustrations below show the possible arrangements recommended by Blue Ox®. Each permanent baseplate safety cable must have an adequate weight rating for the towing system. The weight rating of the two (2) cables together will not qualify.

Do not mount the permanent baseplate safety cables against wires, hoses or brake lines.

These permanent baseplate safety cables should remain installed as long as the baseplate is installed on the vehicle. Permanent baseplate safety cables are to be used in conjunction with, and NOT a replacement for legally required safety cables attaching the towed vehicle to the towing vehicle.

OPTION #1

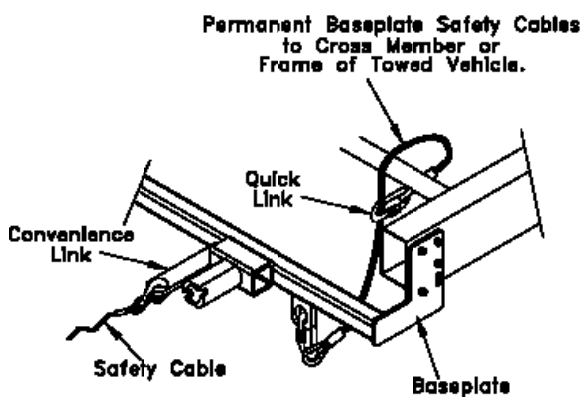

OPTION #2

