



**BX3728 Installation Instructions**  
**1995-04 Toyota Tacoma 4WD Pick-Up**  
**2001-04 Toyota Tacoma Prerunner 2WD**  
**2001-03 Toyota Tacoma Crew Cab 2/ 4WD**  
**1996-98 Toyota 4Runner 4WD**

Installation of this baseplate requires removing the vehicle's tie down brackets and the tow hook.

1. Read the General Instruction Sheet included with this baseplate.
2. The baseplate mounts to the vehicle using two existing bolts and two bolts provided with the baseplate.
3. Notice the tie-down brackets that attach to the frame rails on each side, directly behind the bumper. These are black, formed pieces of metal that bolt underneath the frame rails with two bolts apiece. There is also a tow hook attached to the passenger's side frame rail with the same two bolts.
4. These brackets and tow hook will be removed and the end pieces of the baseplate will bolt to the frame using the existing holes. Begin by removing all four bolts with a 17mm socket. Set the tie-down brackets, tow hook, and passenger's side bolts aside. They will not be reattached to the vehicle.
5. With an assistant, hold the baseplate underneath the frame rails and start the existing driver's side bolts through the baseplate holes. Place a lock and flat washer on the 12mm x 40mm bolts included with the baseplate package and start them through the slots on the passenger's side. Be sure to include Loctite on the bolt threads of all four bolts. When all four bolts are started, they may be tightened. The passenger's side bolts will require a 19mm socket.
6. The dimensional variations between otherwise identical cars can be considerable. While the location and size of the holes in the baseplate were designed to allow for easy installation, it may be necessary to file a hole slightly to allow a bolt to clear.
7. Install the tow bar and safety cables according to the instructions included in their packages.
8. Do not substitute other devices if the tow bar pin and clip are lost.
9. **DEALER OR INSTALLER: BE CERTAIN THE USER RECEIVES THE INSTRUCTION SHEET.**

## Tools Required

17mm Socket

19mm Socket

Loctite Red

## Parts List

Ref. No.	Qty.	Part No.	Description
1	1	61-4630	Weldment, Baseplate, BX3728
2	2	201-0411	12mm-1.25 x 40mm Hex Bolt, Grd 8.8
3	2	203-0105	12mm Lock Washer
4	2	203-0112	12mm Flat Washer
E	2		Existing Bolt
	2	226-0046	Baseplate Safety Cable, 36" CL III (Not Shown)
	2	229-0359	Quicklink, 3/8, ZP (Not Shown)

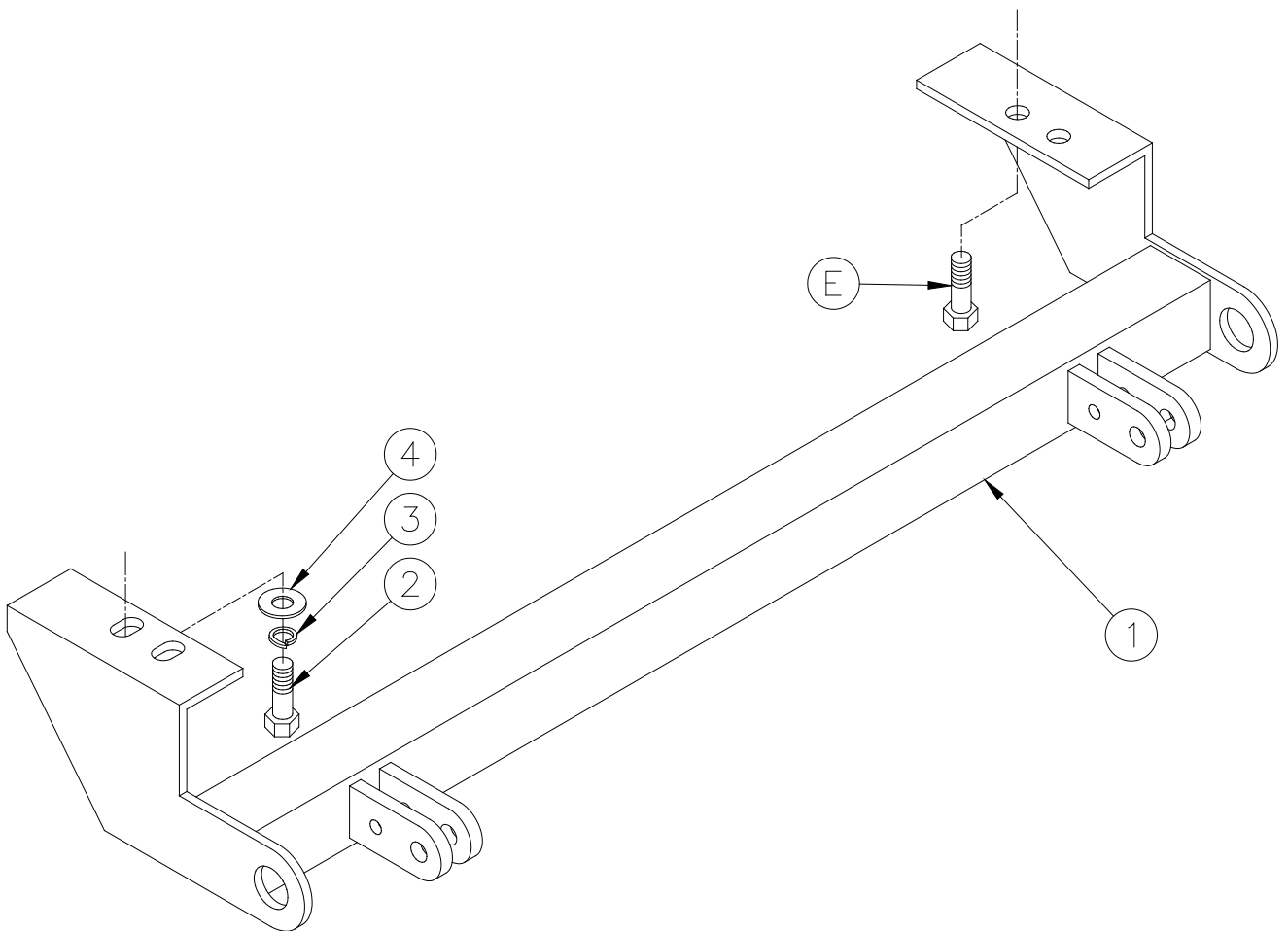

**IMPORTANT:** Use only genuine factory replacement parts on your Base Plate. Do not substitute homemade or non-typical parts. If a bolt is lost or in need of replacement, for your safety and the preservation of your Base Plate, be sure to use a replacement bolt of the same grade (Usually Grade 5, refer to parts list). Repair parts may be ordered through your nearest Blue Ox dealer or distributor.

# General Information

1. It is the owner's responsibility to inspect all towing equipment for cracked welds, missing or worn parts and loose bolts before each towing trip. Be sure to use Loctite® Red on all bolts and tighten to the recommended specifications.
2. It is the owner's responsibility to hook up all towing equipment per manufacturer's instructions/recommendations.
3. Remove the attachment tabs when not in use (if applicable).

## Notice To Baseplate Installer

1. It is YOUR responsibility to watch for:

- Oil cooler and air conditioner lines
- Electrical wires and hoses
- Missing parts or attaching points on the frame

\*\* If the baseplate is improperly installed and is against a wire or hose, it could cause fluid leaks or electrical shorts some time after the actual baseplate installation.

## Permanent Baseplate Safety Cable Installation

Permanent baseplate safety cables are strongly recommended when towing a vehicle with a tow bar. The principle function of the permanent baseplate safety cables is to prevent the towed vehicle from breaking loose in the event the connection between the frame of the towed vehicle and the baseplate fails or becomes disconnected. The cables must be connected from the baseplate to the frame rail or cross member of the vehicle's frame. The illustrations below show the possible arrangements recommended by Blue Ox®. Each permanent baseplate safety cable must have an adequate weight rating for the towing system. The weight rating of the two (2) cables together will not qualify.

***Do not mount the permanent baseplate safety cables against wires, hoses or brake lines.***

These permanent baseplate safety cables should remain installed as long as the baseplate is installed on the vehicle. Permanent baseplate safety cables are to be used in conjunction with, and NOT a replacement for legally required safety cables attaching the towed vehicle to the towing vehicle.

### OPTION #1

Permanent Baseplate Safety Cables to Cross Member or Frame of Towed Vehicle.

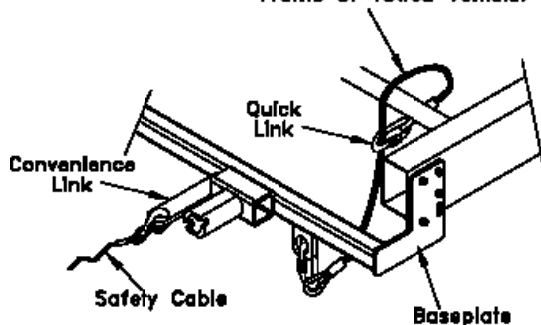

### OPTION #2

Permanent Baseplate Safety Cables to Cross Member or Frame of Towed Vehicle.

