



# BX3615

2012-14 Subaru Impreza (All Models)  
 2008-13 Subaru Impreza WRX (All Models)  
 2010 Impreza Outback Sport  
 2013 Subaru XV Crosstrek  
 Installation Instructions

- Blue Ox® towing products and accessories are intended to be installed by Blue Ox® Dealers who are familiar with our products and have the equipment and knowledge necessary to do “ it work”.
- Many Blue Ox® baseplates are designed to use existing holes and hardware to mount the baseplate to the towed vehicle. Even though bolts are there, do not assume they are adequate for baseplate mounting. Always use the hardware supplied in the hardware kit and existing hardware as specified in the installation instructions.

**Attachment Tab Height: 14”**

**Attachment Tab Width: 18”**

**Please read BOTH these Installation Instructions and the General Instructions prior to installing or operating this equipment.**



Outback/WRX



Impreza/Crosstrek

### Bolt Torque Specifications

Torque in Foot-Pounds for Inch Bolts

Bolt Size	Grade 5	Grade 8
1/4"	10	14
5/16"	19	29
3/8"	33	47
7/16"	54	78
1/2"	78	119
5/8"	154	230
3/4"	257	380

### Bolt Torque Specifications

Torque in Foot-Pounds for Metric Bolts

Bolt Size	Grade 8.8	Grade 10.9
6MM	6	8
8MM	16	22
10MM	31	40
12MM	54	70
14MM	89	117
16MM	161	230
18MM	222	318

**Reference your vehicle owner’s manual for manufacturer’s towing specifications.**



## WARNING

Failure to read and follow these instructions could result in separation of the towed vehicle from the tow bar, causing property damage, loss of towed vehicle, personal injury or death.

## BX3615

### 2008-13 Subaru Impreza WRX (All Models) / 2010 Impreza Outback Sport 2012-14 Subaru Impreza (All Models) / 2013 Subaru XV Crosstrek Installation Instructions

**Instruction Notes:** The fascia and bumper are removed and reinstalled for the baseplate installation. Some drilling and trimming is required.

Place all components that are removed on a flat, sturdy surface. All items will be reinstalled unless otherwise noted after the baseplate is installed.

The dimensional variations between otherwise identical vehicles can be considerable. While the baseplate was designed for easy installation, it may be necessary to tailor the baseplate slightly to compensate for vehicle manufacturer's tolerances.

The BX8869 Tail Light Wiring Kit is recommended for the Impreza/ WRX/Outback models. The BX8848 4-Diode Wiring Kit is recommended for the Crosstrek model.

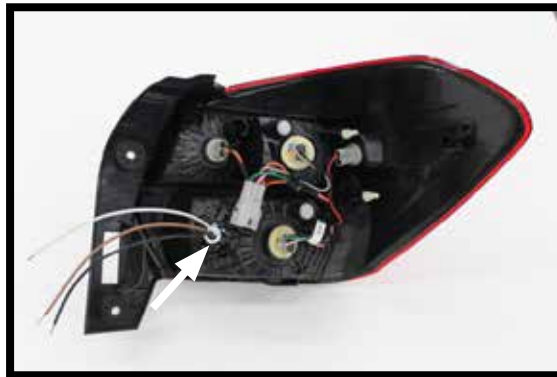

Drill a hole according to the tail light wiring kit instructions.

## **NOTICE**

- Handling of some cosmetic parts when installing this product may require the use of protective covers, rags, specialty tools, etc. to prevent damage.
- When using power drills be aware of the dangers of torque and drill bit length.
- When using a reciprocating saw be aware of objects behind the cutting surface.
- Use a good quality paint to spray cut edges of frame to prevent rusting.
- Be sure that **ALL** electrical connections are plugged in and accessories are functioning properly before reinstalling the fascia.
- The baseplate is computer tested to your vehicle's GVWR, exceeding this weight will void the manufacturer's warranty.
- Be sure to use a sufficient amount of Loctite® Red on all bolt threads before tightening. Tighten all bolts according to the torque chart provided..
- Dealer or installer be certain the user receives these instruction sheet.
- If the baseplate is in an accident, it must be replaced. **DO NOT** use it again! An accident can cause unseen damage and using it again could result in more damage or serious injury. **DO NOT** use the baseplate if it is damaged or missing parts.

# BX3615

## 2008-13 Subaru Impreza WRX (All Models) / 2010 Impreza Outback Sport 2012-14 Subaru Impreza (All Models) / 2013 Subaru XV Crosstrek Installation Instructions

### Tools Required

Flat Chisel  
Utility Knife  
Phillips Screwdriver  
Torque Wrench  
Drill  
Reciprocating Saw  
Tape Measure  
Loctite® RED  
13/32" Drill Bit  
17/32" Drill Bit  
10MM Socket  
12MM Socket  
9/16" Socket  
9/16" Wrench  
3/4" Socket  
3/4" Wrench

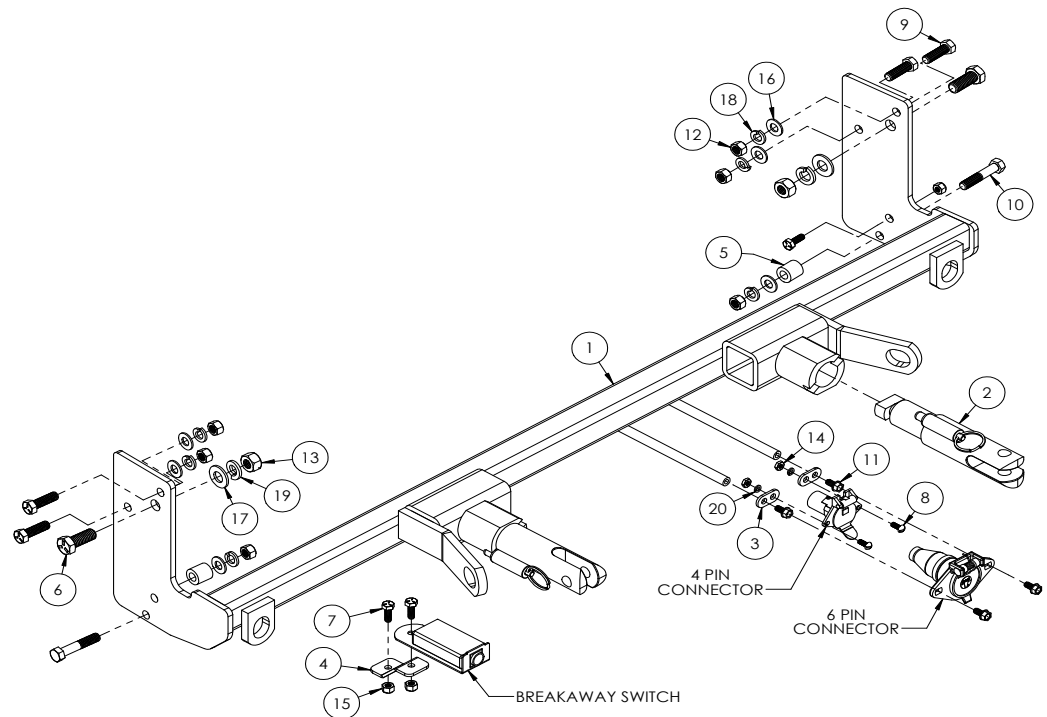

Item No.	Part No.	Description	Qty.
1.....	61-6447 .....	BX3615 Baseplate .....	1
2.....	62-3468 .....	Attachment Tab .....	2
3.....	101-5822 .....	4 Way Connector Adapter .....	2
4.....	101-7599 .....	Breakaway Bracket .....	1
5.....	107-1753 .....	Spacer Tube.....	2
6.....	201-0011 .....	1/2"-13 x 1-1/4" Hex Head Bolt, Grade 5, ZP.....	2
7.....	201-0050 .....	1/4"-20 x 3/4" Hex Head Bolt, Grade 5, ZP .....	3
8.....	201-0192 .....	#10-32 1/2" Round Slotted Head Screw .....	2
9.....	201-0368 .....	3/8"-16 x 1-1/4" Hex Head Bolt, Grade 5, ZP .....	4
10.....	201-0444 .....	3/8"-16 x 2" Hex Head Bolt, Grade 5, ZP .....	2
11.....	201-0979 .....	#12-14 x 1" Self Drilling Screw, ZP .....	2
12.....	202-0003 .....	3/8"-16 Hex Nut, ZP .....	6
13.....	202-0005 .....	1/2"-13 Hex Nut, ZP .....	2
14.....	202-0047 .....	#10-32 Hex Nut.....	2
15.....	202-0102 .....	1/4"-20 Hex Nylon Insert Nut, ZP.....	3
16.....	203-0003 .....	3/8" Flat Washer, ZP .....	6
17.....	203-0005 .....	1/2" Flat Washer, ZP .....	2
18.....	203-0010 .....	3/8" Lock Washer, ZP.....	6
19.....	203-0012 .....	1/2" Lock Washer, ZP.....	2
20.....	203-0054 .....	#10 Lock Washer .....	2
21 (not shown).....	226-0046 .....	36" Class III Baseplate Safety Cable .....	2
22 (not shown).....	229-0359 .....	3/8" Quicklink , ZP.....	2
23 (not shown).....	290-0437 .....	Black Cap Plug Receiver .....	2

### Important:

Use only genuine factory replacement parts on your baseplate. Do **NOT** substitute homemade or non-typical parts. If a bolt is lost or in need of replacement, for your safety and the preservation of your baseplate, be sure to use a replacement bolt of the same grade (In most cases it will be Grade 5, please reference the parts list above). Replacement parts may be ordered through your nearest Blue Ox® Dealer or Distributor. Failing to follow and/or altering these installation instructions in either installation or required equipment will void the manufacturer's warranty. Towing behind a non-motorized vehicle will void the warranty.

BX3615

2008-13 Subaru Impreza WRX (All Models) / 2010 Impreza Outback Sport  
2012-14 Subaru Impreza (All Models) / 2013 Subaru XV Crosstrek  
Installation Instructions

**WRX/Outback Installation Only**

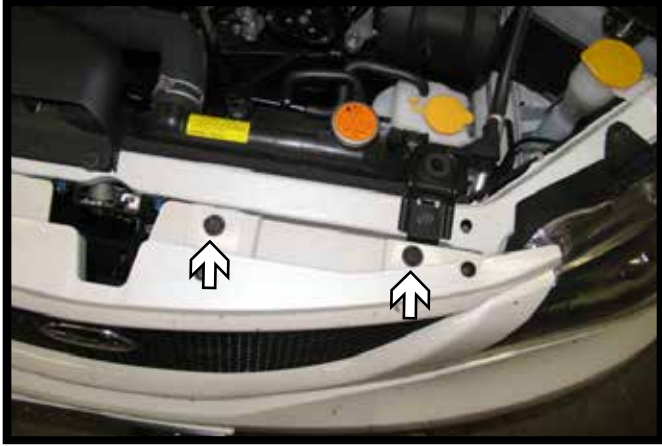

1. Remove the four (4) push pins from the top edge of fascia. There are two (2) per side.



2. Remove the two (2) push pins from the outer edge of the wheel well (white). Then using a Phillips screwdriver, remove the two (2) screws (gray). Do this on both sides of the vehicle.



3. Remove four (4) push pins from the underside of the fascia. There is one (1) in front of the tire on both sides (inset) and two (2) in the middle.

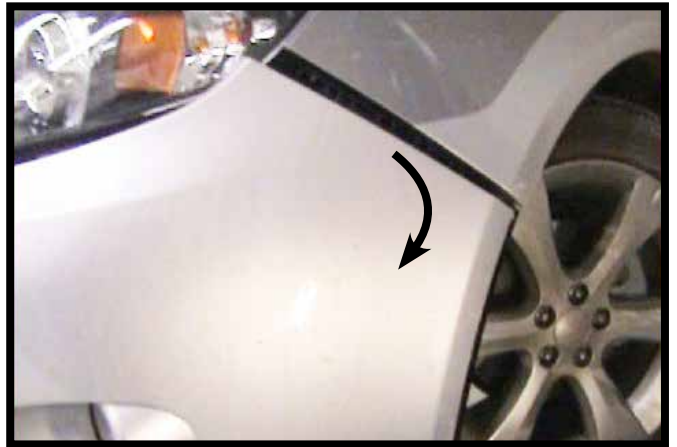

4. Pull fascia corners out to the side of vehicle, then pull fascia forward and set aside carefully.

## BX3615

### 2008-13 Subaru Impreza WRX (All Models) / 2010 Impreza Outback Sport 2012-14 Subaru Impreza (All Models) / 2013 Subaru XV Crosstrek Installation Instructions

#### WRX/Outback Installation Only



5. Using a 10MM socket, remove the screw from the sensor on the driver side.

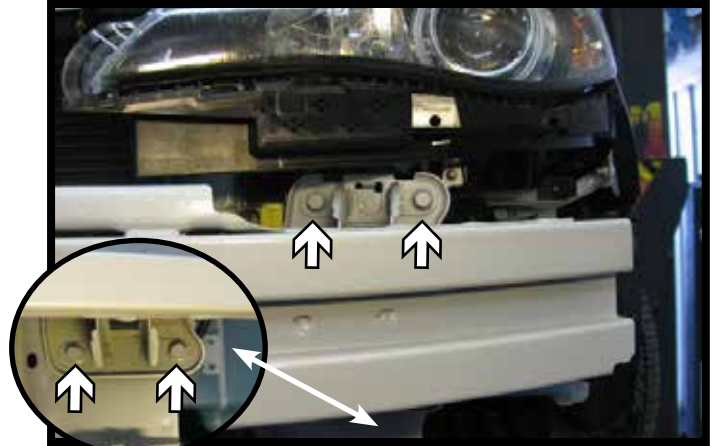

6. Using a 12MM socket, remove the four (4) bolts from the end of the bumper. Do this on both sides of the vehicle. Set the bumper aside.

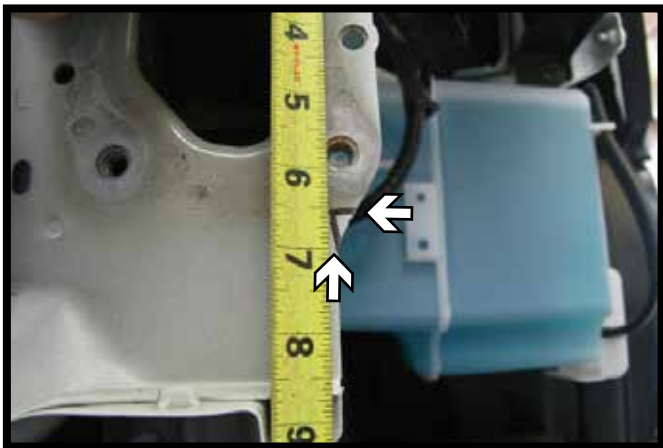

7. Using a reciprocating saw, make a notch down 6-1/2" from the top of the frame and flush with the outside of the frame as shown. Do this on both sides of the vehicle.

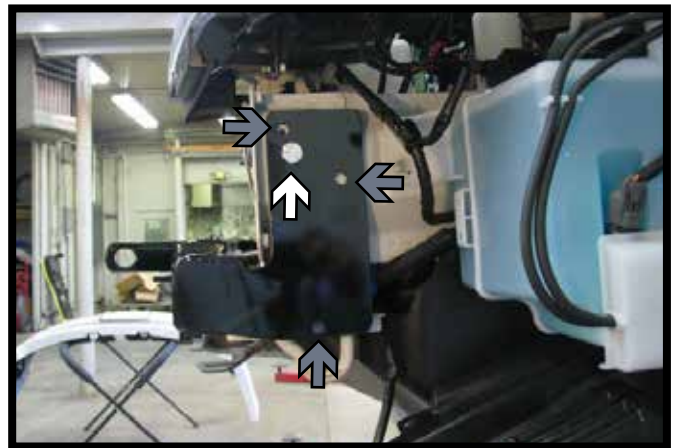

8. Slide the baseplate onto the vehicle lining up the existing hole in the frame with the baseplate (white). Install a 1/2"-13 x 1-1/4" bolt into the hole with 1/2" flat washer, lock washer and nut on the inside of the frame. Do this on both sides of the vehicle. Level the baseplate and fully tighten the 1/2" hardware. Using a 13/32" drill bit, drill the remaining six (6) holes of the baseplate thru the frame (gray). There are three (3) on each side.

## BX3615

### 2008-13 Subaru Impreza WRX (All Models) / 2010 Impreza Outback Sport 2012-14 Subaru Impreza (All Models) / 2013 Subaru XV Crosstrek Installation Instructions

#### WRX/Outback Installation Only

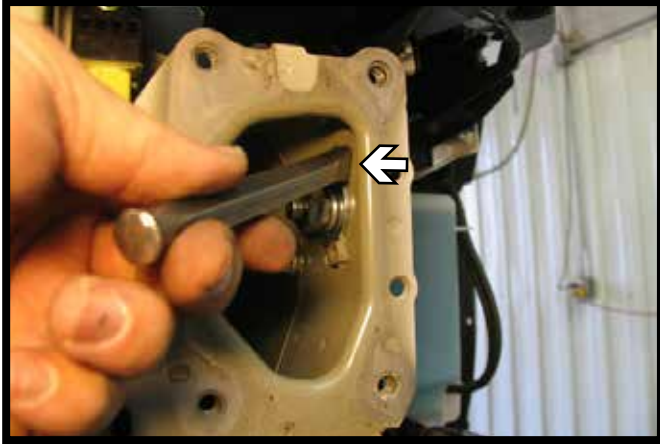

9. After drilling the top hole, use a flat chisel to knock off the nut on the inside of the frame. Do this on both sides of the vehicle.



10. Using a 13/32" drill bit, ream out the existing hole in the sensor bracket on the driver side.

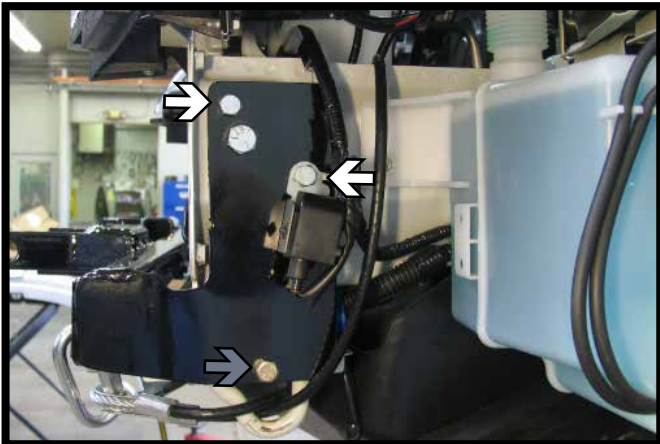

11. Install 3/8"-16 x 1-1/4" bolts into the top two (2) 13/32" holes (white) with the sensor bracket on the lower bolt. Install a 3/8"-16 x 2" bolt with the spacer tube in between the baseplate and frame in the bottom 13/32" hole (gray). Use 3/8" flat washers, lock washers and nuts on the inside of the frame. Do this on both sides of the vehicle. Fully tighten all hardware.



12. Reinstall the metal bumper.

Using a utility knife, cut the plastic splash guard flush with the existing hole approximately 3/4" deep and 3-1/4" long. Do this to both sides of the vehicle.

BX3615

2008-13 Subaru Impreza WRX (All Models) / 2010 Impreza Outback Sport  
2012-14 Subaru Impreza (All Models) / 2013 Subaru XV Crosstrek  
Installation Instructions

**Impreza/Crosstrek Installation Only**

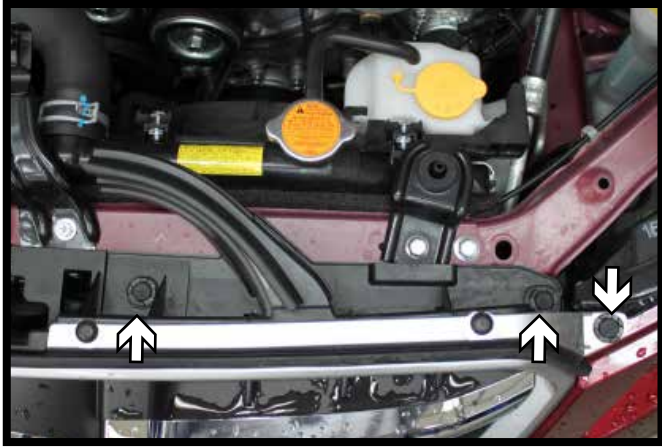

1. Remove the six (6) push pins from the top edge of fascia. There are three (3) per side.



2. Remove the two (2) push pins from the outer edge of the wheel well. Do this on both sides of the vehicle.



3. Remove the eight (8) push pins from the underside of the fascia. There are three (3) in each corner and two (2) in the middle.



4. Unsnap the corners of the fascia from the fender. Remove the fascia from the vehicle, disconnecting any electrical connections and set the fascia aside.

BX3615

2008-13 Subaru Impreza WRX (All Models) / 2010 Impreza Outback Sport  
2012-14 Subaru Impreza (All Models) / 2013 Subaru XV Crosstrek  
Installation Instructions

**Impreza/Crosstrek Installation Only**



5. **2012-13 Models:** Using a 10MM socket, remove the screw from the sensor on the driver side.



5. **2014 Models:** Using a 10MM socket, remove the screw from the sensor on the passenger side.

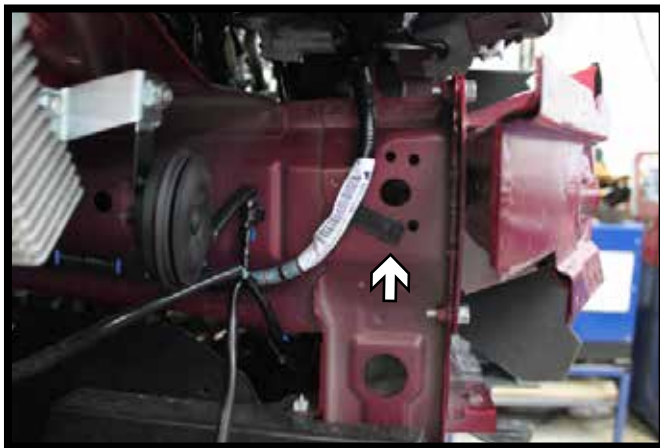

6. On the passenger side, remove the wire loom push pin and move the loom away for baseplate installation.

7. **2014 Models:** Remove the push pin from the filler neck (top left inset). Using a 10MM socket, remove the three (3) screws from the washer reservoir. Disconnect/Plug all lines and set the reservoir aside.

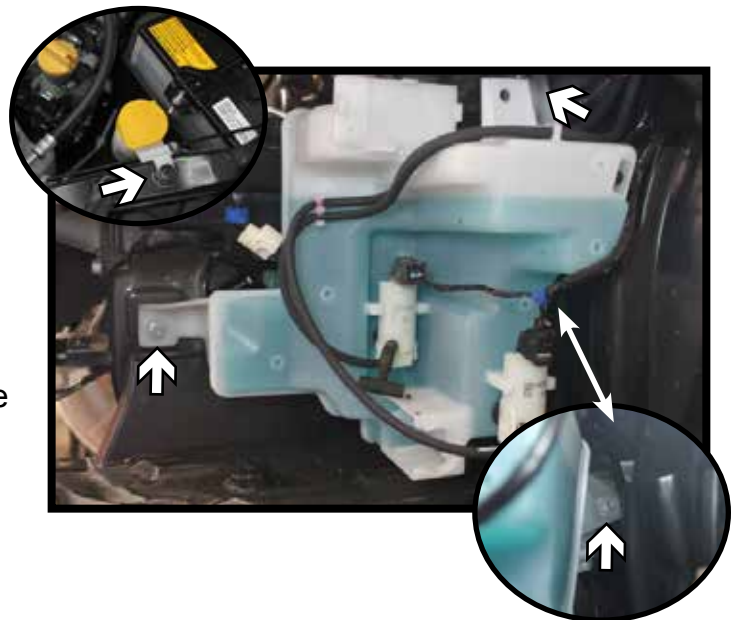



## BX3615

2008-13 Subaru Impreza WRX (All Models) / 2010 Impreza Outback Sport  
2012-14 Subaru Impreza (All Models) / 2013 Subaru XV Crosstrek  
Installation Instructions

### Impreza/Crosstrek Installation Only

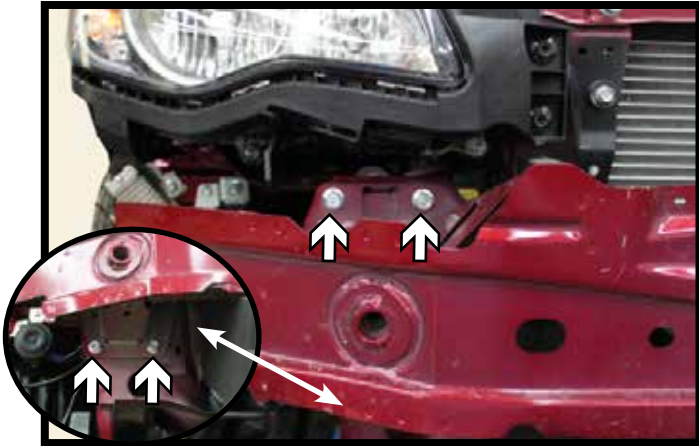

8. Using a 12MM socket, remove the four (4) bolts from the bumper. There are two (2) on the top and bottom of the bumper. Do this on both sides of the vehicle. Set the bumper aside.



9. Trim off the lower foam support. Do this on both sides of the vehicle.



10. Using a 12MM socket, remove the bolt from the horn bracket. Disconnect the electrical lines. The horn will need to be re-orientated for baseplate clearance.



11. Using a 10MM socket, loosen the bolt on the backside of the bracket. Position the arm as shown and retighten the bolt. Reinstall the horn bracket to the vehicle and hook up the electrical connections.

## BX3615

2008-13 Subaru Impreza WRX (All Models) / 2010 Impreza Outback Sport  
2012-14 Subaru Impreza (All Models) / 2013 Subaru XV Crosstrek  
Installation Instructions

### Impreza/Crosstrek Installation Only

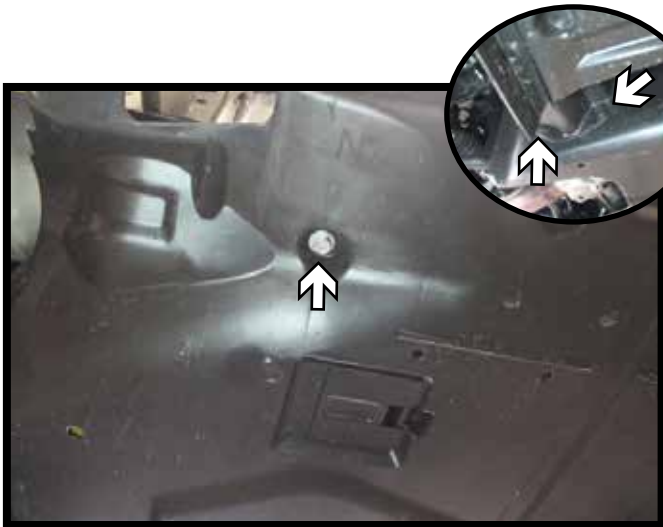

12. **2014 Models:** Drop the front of belly pan down for baseplate installation. Using a 12MM socket, remove the two (2) screws from the underneath. Then remove the two (2) push pins from the sides (inset). Unsnap the front lip from the brackets.



13. **2014 Models:** Using a 10MM socket, remove the screw from the belly pan bracket and set aside. Do this on both sides of the vehicle.



14. **2014 Models:** On the driver side, using a 14MM socket, remove the four (4) bolts from the frame extension. There are two (2) on in the back and two (2) in front. Set the extension aside. Behind the extension remove the wire loom from the frame (inset).

## BX3615

2008-13 Subaru Impreza WRX (All Models) / 2010 Impreza Outback Sport  
2012-14 Subaru Impreza (All Models) / 2013 Subaru XV Crosstrek  
Installation Instructions

### Impreza/Crosstrek Installation Only

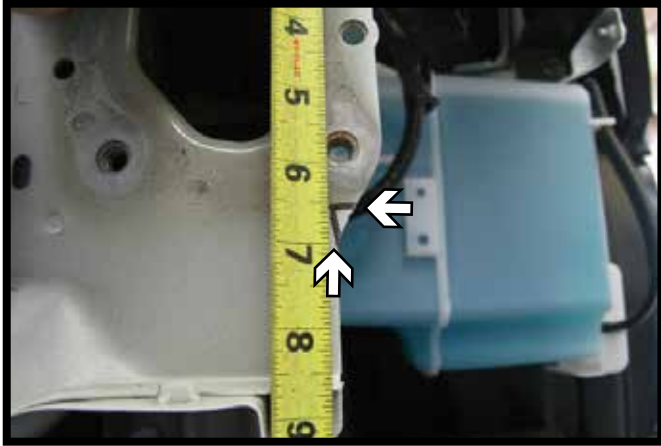

15. Using a reciprocating saw, make a notch down 6-1/2" from the top of the frame and flush with the outside of the frame as shown. Do this on both sides of the vehicle.

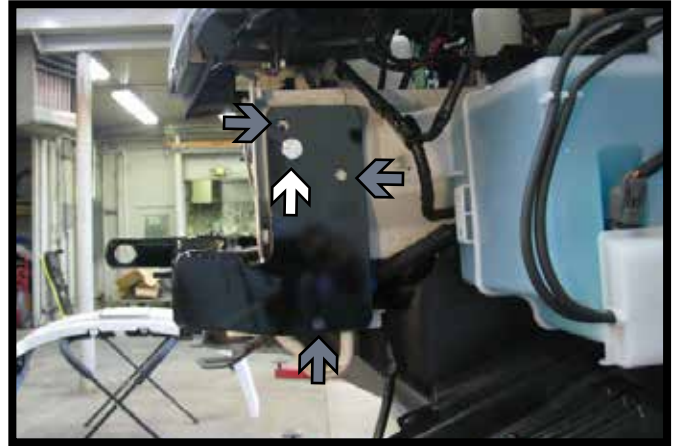

16. Slide the baseplate onto the vehicle lining up the existing hole in the frame with the baseplate (white). Install a 1/2"-13 x 1-1/4" bolt into the hole with 1/2" flat washer, lock washer and nut on the inside of the frame. Do this on both sides of the vehicle. Level the baseplate and fully tighten the 1/2" hardware. Using a 13/32" drill bit, drill the remaining six (6) holes of the baseplate thru the frame (gray). There are three (3) on each side.

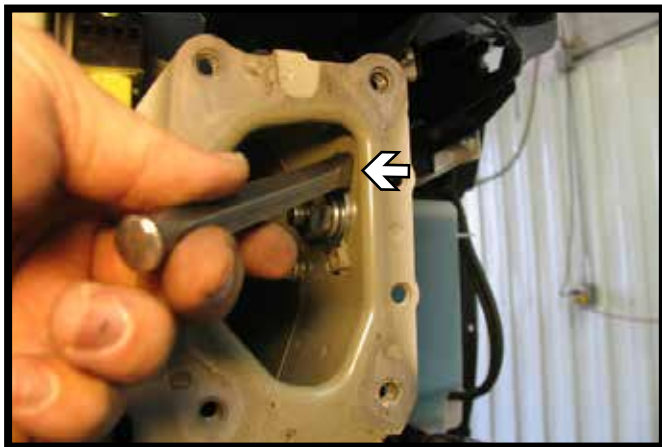

17. **2012-13 Models:** After drilling the top hole, use a flat chisel to knock off the nut on the inside of the frame. Do this on both sides of the vehicle.  
**2014 Models:** Only the passenger side will need the nut removed.

## BX3615

2008-13 Subaru Impreza WRX (All Models) / 2010 Impreza Outback Sport  
2012-14 Subaru Impreza (All Models) / 2013 Subaru XV Crosstrek  
Installation Instructions

### Impreza/Crosstrek Installation Only



18. Using a 13/32" drill bit, ream out the existing hole in the sensor bracket.  
Reattach the sensor to appropriate side of the vehicle when installing the 3/8" baseplate bolts in the following step.

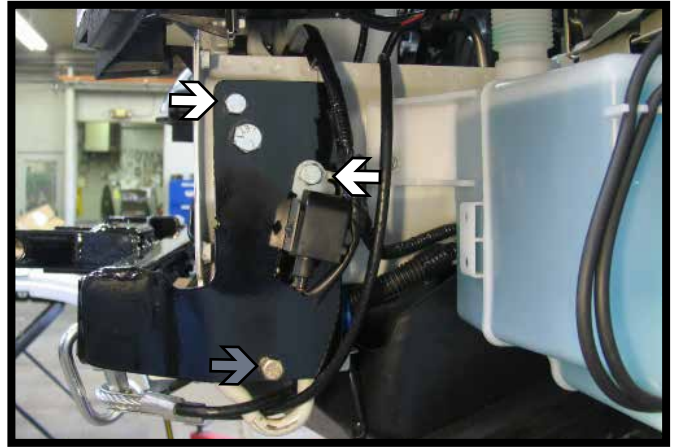

19. Install 3/8"-16 x 1-1/4" bolts into the top two (2) 13/32" holes (white) with the sensor bracket on the lower bolt. Install a 3/8"-16 x 2" bolt with the spacer tube in between the baseplate and frame in the bottom 13/32" hole (gray). Use 3/8" flat washers, lock washers and nuts on the inside of the frame. Do this on both sides of the vehicle. Fully tighten all hardware.



20. Using a utility knife, cut the plastic splash guard flush as shown. Do this to both sides of the vehicle and reinstall to the vehicle (left).

Reinstall the washer reservoir, bumper, frame extension and belly pan & brackets.

**2014 Models:** The bottom outside bumper bolts will need to be shortened to clear the baseplate (middle). Use the supplied 1/4" hardware to reinstall the front arm of the washer reservoir to the baseplate (right). (Note: Baseplates manufactured prior to 9/14 will not have the existing hole for the reservoir and this hole will need to be drilled.)

## BX3615

### 2008-13 Subaru Impreza WRX (All Models) / 2010 Impreza Outback Sport 2012-14 Subaru Impreza (All Models) / 2013 Subaru XV Crosstrek Installation Instructions **Final Installation for All Models**

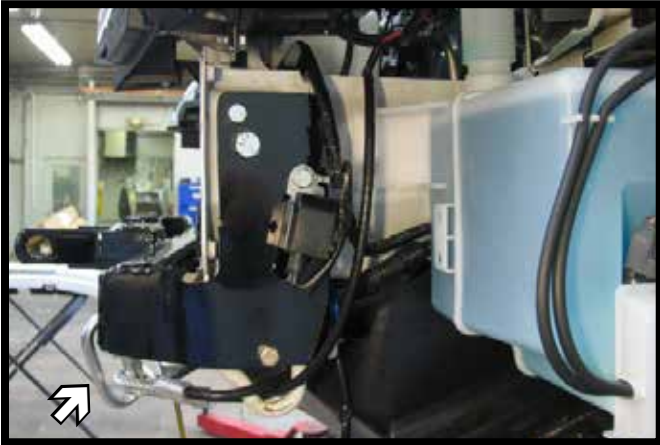

Attach the permanent baseplate safety cables to the provided convenience link on the baseplate. The photo above shows the recommended installation of the cables to frame of vehicle. Additional options may interfere with suggested mounting; in this case, secure the cables to a solid piece of the frame as described in the instructions included with the permanent baseplate safety cables. Be sure the safety cables do not rub against any hoses or moving parts. Do this on **BOTH** sides of the vehicle. (Left)

**Optional Breakaway:** Install the bracket to the vehicle as shown in the desired location with the supplied 1/4" hardware. (Right)

Hold the fascia as close to its original position, mark and trim the fascia around the convenience links and attachment tabs. Reinstall the fascia and reconnect all electrical connections.



# General Information

1. It is the owner's responsibility to inspect all towing equipment for cracked welds, missing or worn parts and loose bolts before each towing trip. Be sure to use Loctite® Red on all bolts and tighten to the recommended specifications.
2. It is the owner's responsibility to hook up all towing equipment per manufacturer's instructions/recommendations.
3. Remove the attachment tabs when not in use (if applicable).

## Notice To Baseplate Installer

1. It is YOUR responsibility to watch for:

- Oil cooler and air conditioner lines
- Electrical wires and hoses
- Missing parts or attaching points on the frame

\*\* If the baseplate is improperly installed and is against a wire or hose, it could cause fluid leaks or electrical shorts some time after the actual baseplate installation.

## Permanent Baseplate Safety Cable Installation

Permanent baseplate safety cables are strongly recommended when towing a vehicle with a tow bar. The principle function of the permanent baseplate safety cables is to prevent the towed vehicle from breaking loose in the event the connection between the frame of the towed vehicle and the baseplate fails or becomes disconnected. The cables must be connected from the baseplate to the frame rail or cross member of the vehicle's frame. The illustrations below show the possible arrangements recommended by Blue Ox®. Each permanent baseplate safety cable must have an adequate weight rating for the towing system. The weight rating of the two (2) cables together will not qualify.

***Do not mount the permanent baseplate safety cables against wires, hoses or brake lines.***

These permanent baseplate safety cables should remain installed as long as the baseplate is installed on the vehicle. Permanent baseplate safety cables are to be used in conjunction with, and NOT a replacement for legally required safety cables attaching the towed vehicle to the towing vehicle.

### OPTION #1

Permanent Baseplate Safety Cables to Cross Member or Frame of Towed Vehicle.

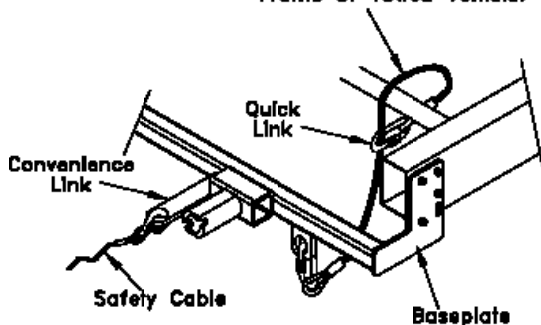

### OPTION #2

Permanent Baseplate Safety Cables to Cross Member or Frame of Towed Vehicle.

