

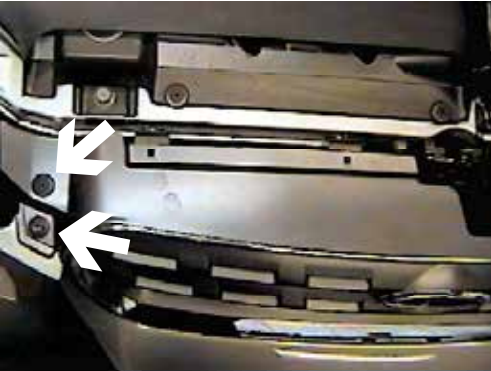

BX3613 Installation Instructions 2005-09 Subaru Outback

Strong As An Ox™ The front fascia, headlight assembly and metal bumper are removed for baseplate installation. Air bag sensors are relocated. Trimming of air dam is required. Drilling is required. The BX8869 is available for the vehicle. Attachment Tabs are 24 inches center to center and a height of 15 inches.



1. Remove metric bolt with the 10MM socket and one phillips push pin on top edge of grill, both sides.



2. Using a small flat screw driver, push the four tabs down between the top edge of fascia and upper cross member while pulling fascia forward to release from cross member.



3. Just forward of front tire and inside wheel well is one push pin to remove from fascia's upper corner.



4. Forward of front tires are four push pins to remove from lower edge of fascia, both sides.



5. Remove push pin from tab on lower edge of fascia, both sides.



6. Remove push pin from tab on lower center edge of fascia.



Strong As An Ox™



7. Using the 10MM socket, remove metric bolt from head light assembly and one push pin, both sides.

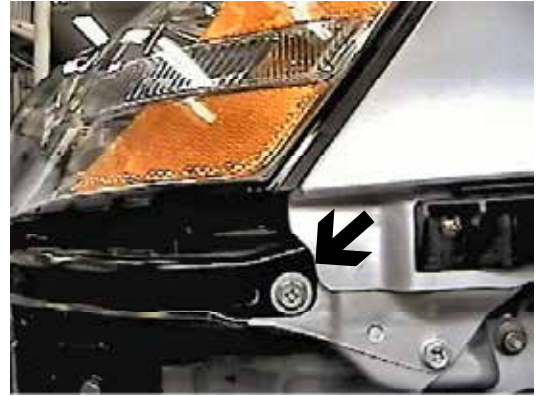

8. Remove metric bolt from lower side of head light assembly using the 10MM socket, both sides.

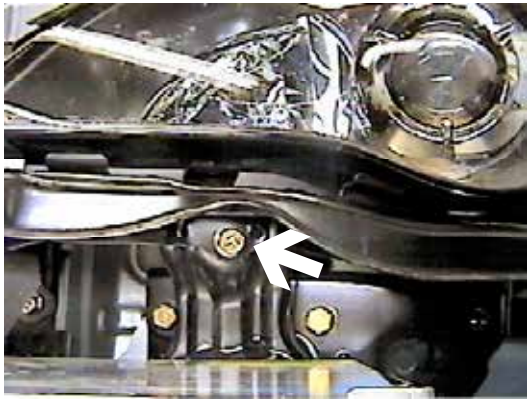

9. Remove metric bolt from front of head light assembly with the 10MM socket, both sides.

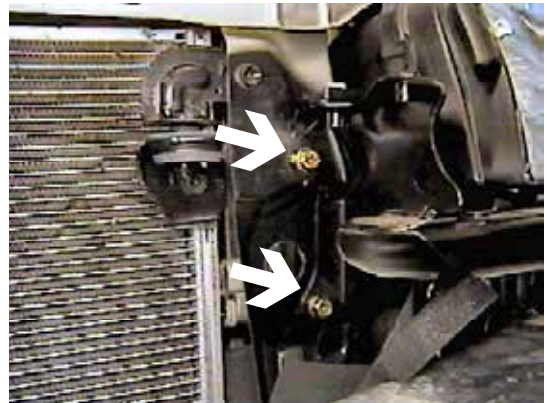

10. Remove two metric bolts from headlight assembly next to radiator, both sides, pull assemblies forward, unplug and set aside.

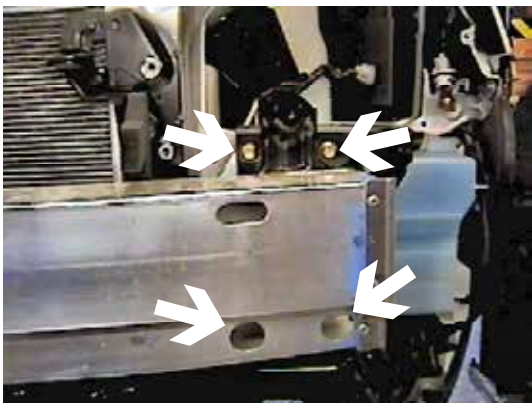

11. Remove four metric bolts from both sides of metal bumper, pull forward and set aside.



12. Using the utility knife mark and cut lower air dam from both sides. This will allow open area for baseplate installation.



Strong As An Ox™



13. Using the 10MM socket, remove two metric bolts from air bag sensor and carefully set out of the way, both sides.

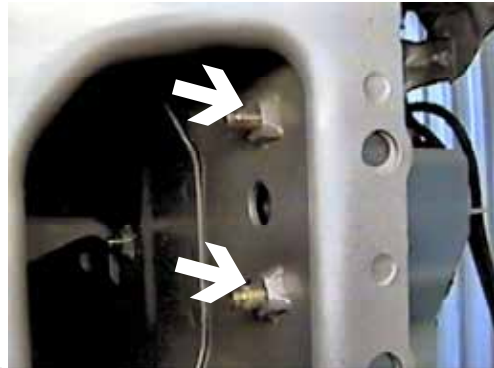

14. Using the flat chisel, remove the two weld nuts inside frame rail, both sides. This will allow enough room for nut plate on the inside of frame.

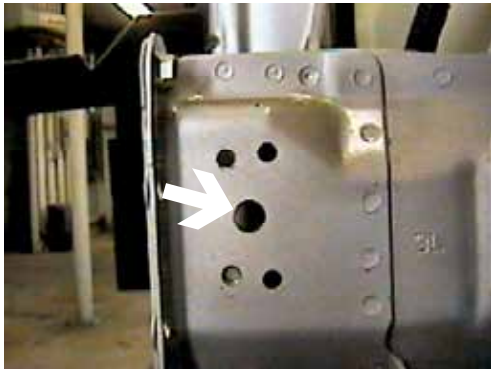

15. Using the 17/32" drill bit, drill out the existing larger hole in frame rail, both sides.

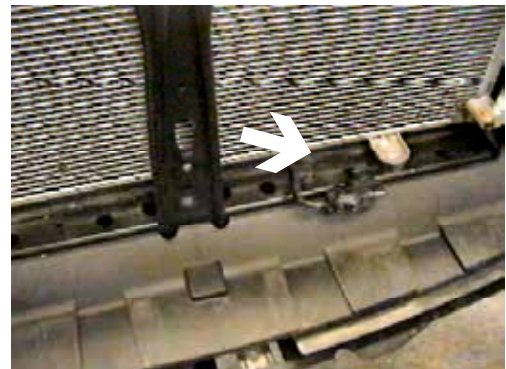

16. Bend temperature bracket and sensor back toward radiator. It may be necessary to bend bracket more when baseplate is installed and may differ from vehicle to vehicle.

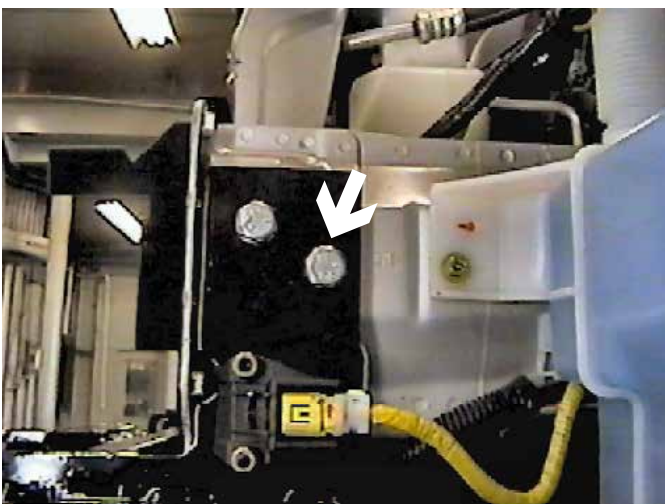

17. Hold baseplate to align with existing drilled hole on frame, both sides and clamp to frame with vise grips. Using the baseplate as a template, drill a hole into frame with the 17/32" drill bit, both sides. Insert 61-5288 into end of frame rail to align with drill holes on driver's side, tighten 1/2" hex bolts and lock washers. Be sure baseplate is level with vehicle. Insert 61-5289 into end of frame rail to align with drill holes on passenger's side, tighten 1/2" hex bolts and lock washers. **Be sure and use loctite red on all bolts before tightening. Torque all bolts according to torque chart in General Instructions.**



Strong As An Ox™



18. Using the baseplate as a template, drill lower hole into lower frame webbing just inside tie down opening. Insert the 3/8" hex bolt into drilled hole and tighten 3/8" lock washer and 3/8" hex nut, both sides. **Be sure and use loctite red on all bolts before tightening. Torque all bolts according to torque chart in General Instructions.**



19. Set fascia face down on a soft material to prevent scratching, mark and cut back side of fascia just between fog lights top of opening, as shown in photo, using the utility knife. Reinstall head light assemblies, metal bumper and fascia. **Be sure all electrical components are plugged in properly.**

20. The dimensional variations between otherwise identical cars can be considerable. While the location and size of the holes in the baseplate were designed to allow for easy installation, it may be necessary to file a hole slightly to allow a bolt to clear.

21. Install the tow bar and safety cables according to the instructions included in their packages.

22. Do **not** substitute other devices if the tow bar pin and clip are lost.

23. **DEALER OR INSTALLER: BE CERTAIN THE USER RECEIVES THE INSTRUCTION SHEET.**



Location for the Bx8869 on driver's side tail light assembly.

IMPORTANT: Use only genuine factory replacement parts on your Base Plate. Do not substitute homemade or nontypical parts. If a bolt is lost or in need of replacement, for your safety and the preservation of your Base Plate, be sure to use a replacement bolt of the same grade (Usually Grade 5, refer to parts list). Repair parts may be ordered through your nearest **Blue Ox** dealer or distributor.



Strong As An Ox™

Tools Required

10MM Socket
12MM Socket
Small Flat Screw Driver

7/16" Socket
9/16" Socket
Flat Chisel

3/4" Socket
Loctite Red
Utility Knife

13/32" Drill Bit
17/32" Drill Bit

Parts List

Ref. No.	Qty.	Part No.	Description
1	1	61-6050	Weldment, Base Plate, BX3613
2	1	61-5288	Driver Side, 1/2" Nut Plate
3	1	61-5289	Passenger Side, 1/2" Nut Plate
4	2	107-1768	Pipe, 3/8 SCH 40 x 3/4 Inch
5	4	201-0051	1/2-13 x 1 1/2 Bolt, Grd. 5, ZP
6	4	203-0012	1/2 Lock Washer, ZP
7	2	201-0444	3/8-16 x 2 Bolt, Grd. 5, ZP
8	2	203-0010	3/8 Lock Washer, ZP
9	2	202-0003	3/8-16 Hex Nut, ZP
10	4	203-0008	1/4 Lock Washer
11	4	202-0001	1/4-20 Hex Nut
12	2	201-0979	#12-14 x 1" Self Drilling Screw, ZP
13	2	201-0192	#10-32 x 1/2 Slot, Rd. Hd. Screw
14	2	203-0054	#10 Lock Washer
15	2	202-0047	#10-32 Hex Nut
16	2	101-5822	Adapter, 4 Way Connector
17	2	62-3468	Attachment, Assembly, SF/ SB (R)
	2	226-0046	Baseplate Safety Cable, 36" CL III (Not Shown)
	2	229-0359	Quicklink, 3/8, ZP (Not Shown)
	2	290-0437	Receiver, Cap Plug (BLK) (Not Shown)

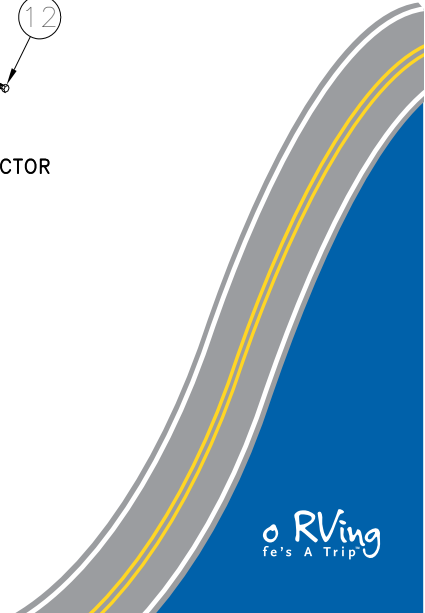
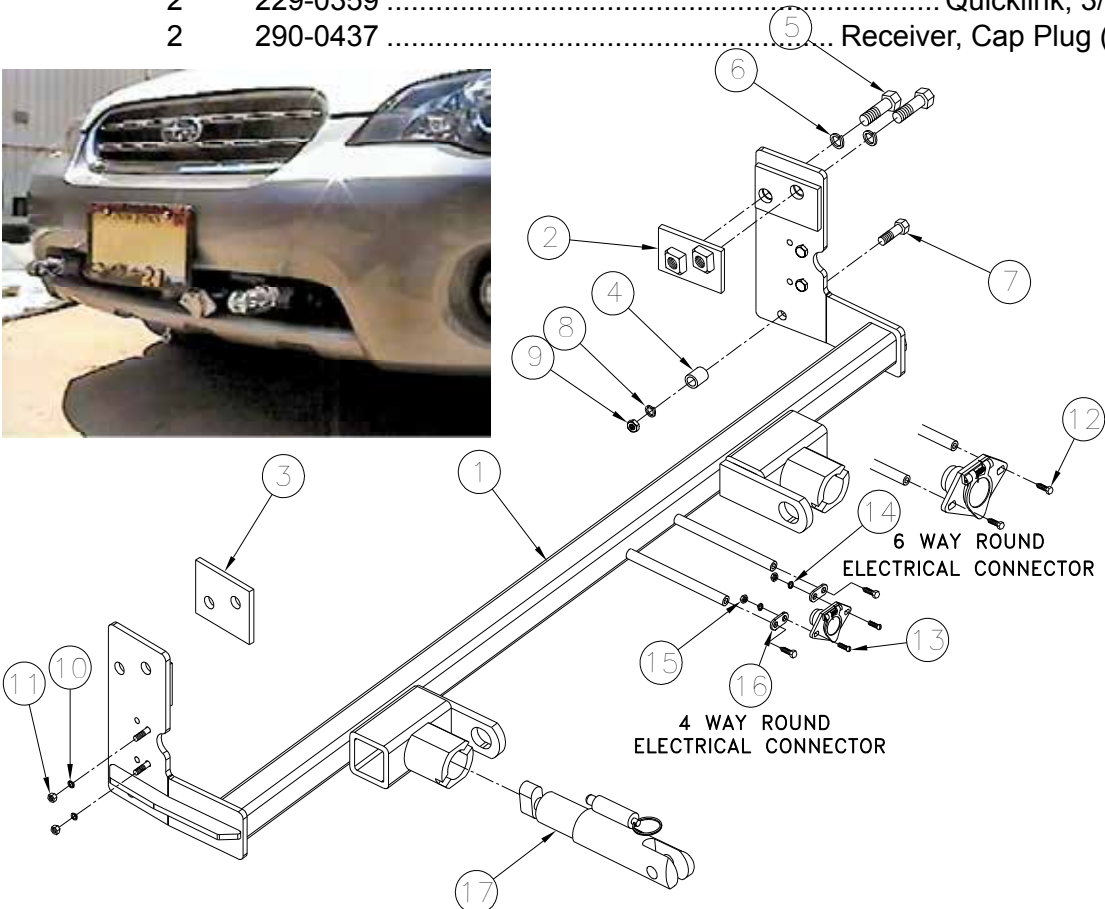

General Information

1. It is the owner's responsibility to inspect all towing equipment for cracked welds, missing or worn parts and loose bolts before each towing trip. Be sure to use Loctite® Red on all bolts and tighten to the recommended specifications.
2. It is the owner's responsibility to hook up all towing equipment per manufacturer's instructions/recommendations.
3. Remove the attachment tabs when not in use (if applicable).

Notice To Baseplate Installer

1. It is YOUR responsibility to watch for:

- Oil cooler and air conditioner lines
- Electrical wires and hoses
- Missing parts or attaching points on the frame

** If the baseplate is improperly installed and is against a wire or hose, it could cause fluid leaks or electrical shorts some time after the actual baseplate installation.

Permanent Baseplate Safety Cable Installation

Permanent baseplate safety cables are strongly recommended when towing a vehicle with a tow bar. The principle function of the permanent baseplate safety cables is to prevent the towed vehicle from breaking loose in the event the connection between the frame of the towed vehicle and the baseplate fails or becomes disconnected. The cables must be connected from the baseplate to the frame rail or cross member of the vehicle's frame. The illustrations below show the possible arrangements recommended by Blue Ox®. Each permanent baseplate safety cable must have an adequate weight rating for the towing system. The weight rating of the two (2) cables together will not qualify.

Do not mount the permanent baseplate safety cables against wires, hoses or brake lines.

These permanent baseplate safety cables should remain installed as long as the baseplate is installed on the vehicle. Permanent baseplate safety cables are to be used in conjunction with, and NOT a replacement for legally required safety cables attaching the towed vehicle to the towing vehicle.

OPTION #1

Permanent Baseplate Safety Cables to Cross Member or Frame of Towed Vehicle.

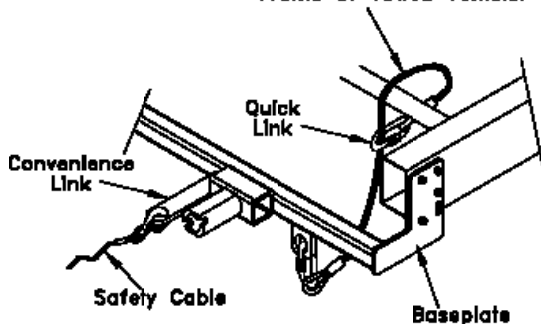

OPTION #2

Permanent Baseplate Safety Cables to Cross Member or Frame of Towed Vehicle.

