

2008-09 Saturn Astra Installation Instructions

Please read BOTH these Installation Instructions and the General Instructions before attempting to install or operate this equipment.

1. Blue Ox® towing products and accessories are intended to be installed by Blue Ox® Dealers who are familiar with our products and have the equipment necessary and knowledge to do “fit work”.
2. Many Blue Ox® Baseplates are designed to use existing holes and hardware to mount the baseplate to the towed vehicle. Even though bolts are there, do not assume they are adequate for baseplate mounting. Always use hardware supplied in the hardware kit and existing hardware specified in the Baseplate Installation Instructions.

Attachment Tab Height: 15 3/4”

Attachment Tab Width: 18”

Bolt Torque Specifications

Torque in Foot-Pounds for Metric Bolts

Bolt Size	Grade 8.8	Grade 10.9
6MM	6	8
8MM	16	22
10MM	31	40
12MM	54	70
14MM	89	117

Confirm the towability and pre-towing procedures for your vehicle with the owner’s manual or contact the vehicle’s manufacturer for specific towing procedures.

Bolt Torque Specifications

Torque in Foot-Pounds for Inch Bolts

Bolt Size	Grade 5	Grade 8
1/4”	10	14
5/16”	19	29
3/8”	33	47
7/16”	54	78
1/2”	78	119
5/8”	154	230



! WARNING

Failure to read and follow these instructions could result in separation of the towed vehicle from the tow bar, causing property damage, loss of towed vehicle, personal injury or death.

BX3333

2008-09 Saturn Astra

Installation Instructions

Parts List

Ref. No.	Qty.	Part #	Description
1	1	61-6513	WLDM'T, BASEPLATE, BX3333
2	1	61-6514	WLDM'T, PLATE, END, DS, BX3333
3	1	61-6516	WLDM'T, PLATE, END, PS, BX3333
4	1	61-5208	WLDT, NUT PLT, 1/4X1X1, 3/8 BLT WIR
5	4	201-0368	3/8-16 X 1 1/4 HEX HEAD BOLT,GRD. 5
6	1	201-0444	3/8-16 X 2 HEX BOLT GRADE 5 ZP.
7	9	203-0010	3/8 LOCK WASHER, ZP
8	4	202-0003	3/8-16 HEX NUT, ZP
9	4	201-0011	1/2-13 X 1 1/4 HEX BOLT GRD.5, ZP
10	4	203-0012	1/2 LOCK WASHER, ZP
11	2	201-0418	8MM-1.25 X 35MM HEX BOLT GRD.8.8 ZP
12	3	203-0003	3/8 FLAT WASHER, ZP
13	2	202-0118	8MM-1.25 HEX NUT, ZP
14	2	201-0979	#12-14 X 1" SELF DRILLING SCREW, ZP
15	2	201-0192	10-32 X 1/2 SLOT, RD. HD. SCREW
16	2	203-0054	#10 LOCK WASHER
17	2	202-0047	#10-32 HEX NUT
18	2	101-5822	ADAPTER, 4 WAY CONNECTOR
19	2	62-3469	ATT TAB ASSY, REM, SF/LB, 1 HOLE
	2	226-0046	BASEPLATE SAFETY CABLE, 36" CL III, (NS)
	2	229-0359	QUICKLINK, 3/8, ZP, (Not Shown)
	2	290-0437	RECEIVER, CAP PLUG (BLK), (Not Shown)

Tools Required

10MM Socket	T20 Torx
13MM Socket	T25 Torx
9/16" Socket	Reciprocating Saw
9/16" Wrench	Flat Screw Driver
13/32" Drill Bit	Hack Saw Blade
	Loctite® RED

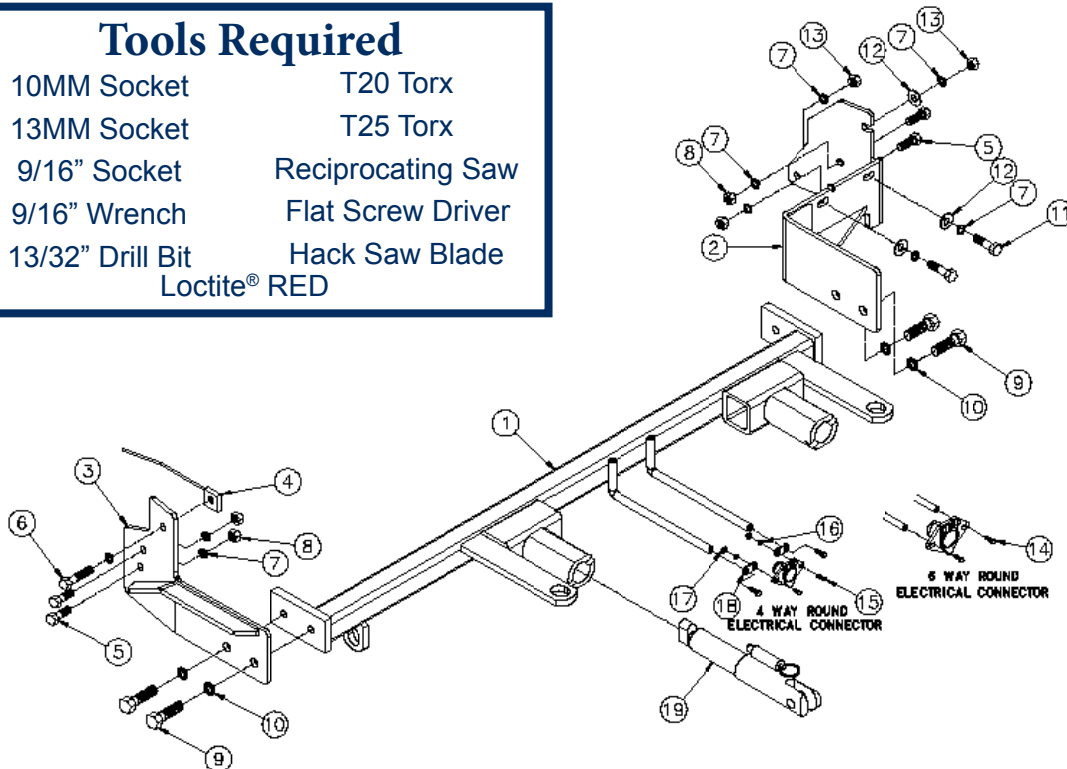

Important:

Use only genuine factory replacement parts on your baseplate. Do NOT substitute homemade or non-typical parts. If a bolt is lost or in need of replacement, for your safety and the preservation of your baseplate, be sure to use a replacement bolt of the same grade (In most cases it will be Grade 5, please reference the parts list above).

BX3333

2008-09 Saturn Astra

Installation Instructions

Attachment Tabs:

Motorhome mount tow bars are recommended for use with this baseplate. Due to the design of the removable tabs, the RangeFinderII, Adventurer, and Ambassador tow bars can not be used. The Acclaim tow bar may be used, but will not fold and store on the front of the vehicle. Adapters, except the BX8833 and BX88151, can not be used with this baseplate.

Instructions:

The front fascia and washer reservoir are removed and reinstalled during the baseplate installation. Drilling is required. Trimming of the frame and fascia is required. The radiator support bracket is removed.

The dimensional variations between otherwise identical vehicles can be considerable. While the baseplate was designed for easy installation, it may be necessary to tailor the baseplate slightly to compensate for auto manufacturer's tolerances. These minor adjustments may include filing a hole slightly, bending electrical rods or bending end plates.

The BX8869 Bulb and Socket Wiring Kit is recommended for this vehicle.



Possible location for the BX8869 Bulb and Socket Kit.

Installation Instructions:



1. Using a 25 Torx, remove three metric bolts from the top side of the fascia. Set the bolts aside to be reinstalled later.



2. Using a 20 Torx, remove two screws from just forward of the front tire on the edge of the wheel well cover. Set screws aside to be reinstalled later. Do this to both sides of the vehicle.

Handling of some cosmetic parts when installing this product may require the use of protective covers, rags, specialty tools, etc. to prevent damage.

BX3333

2008-09 Saturn Astra

Installation Instructions



3. Remove three push pins from underneath on the bottom edge of the belly pan. Set the push pins aside to be reinstalled later.



4. On the passenger side only, up in behind the front tire, unplug the master connector.



5. Remove two push pins (white arrows) from each side of the front of the fascia. Set push pins aside to be reinstalled later. Push down on the four tabs (gray arrows) across the front as the fascia is being removed. Pull fascia's upper corners out to the side of the vehicle and straight forward. Set the fascia aside carefully to be reinstalled later.
7. Using a 10MM socket, remove one metric bolt from under the bumper holding the washer reservoir. Set the metric bolt aside to be reinstalled later.



6. Using the 10MM socket, remove the top metric bolt from the washer reservoir. Set the bolt aside to be reinstalled later.



BX3333
2008-09 Saturn Astra
Installation Instructions

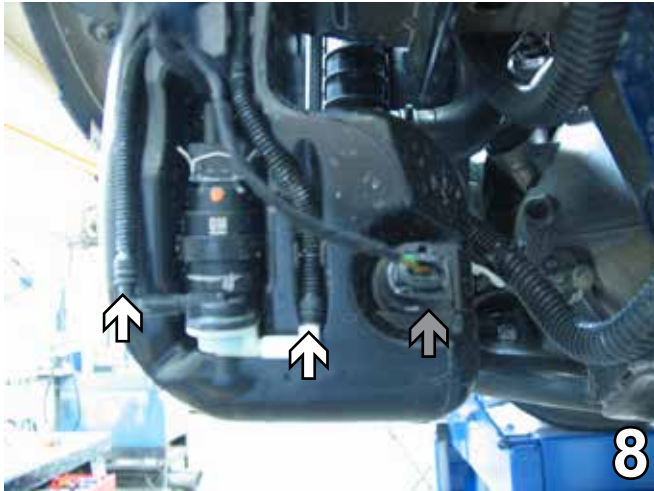

8. Pull the three washer reservoir hoses out. Disconnect two (white arrows) and plug their ends. Unplug the electrical connection (gray arrow). Set the washer reservoir aside to be reinstalled later.

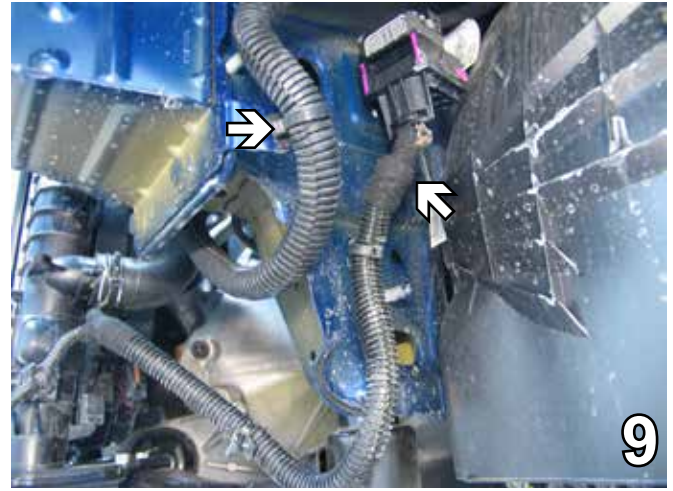

9. After the washer reservoir is removed, unclamp the two hoses and pull up out of way. Do this on both sides.

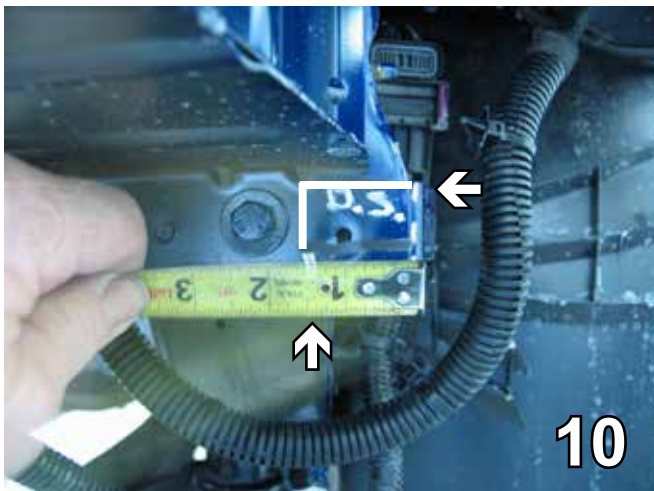

10. On the driver's side, cut off the tab then over 1 1/2" and straight down.



11. On the passenger side, cut around the ridge to the top then straight out.



Using a good quality paint, spray cut edges of frame to prevent rusting.

12. On the driver's side, cut the radiator support bracket off. Be careful not to cut the radiator.

BX3333

2008-09 Saturn Astra

Installation Instructions



13. On the passenger side, using a 25 Torx remove the bolt. Then trim the plastic.



14. Cut straight across under the horn, making sure to be level. Do this on both sides.



15. Using the hack saw blade, cut out the fascia middle horizontal rib to the outside of the sensor. Remove the whole piece to open the area up for baseplate installation. Do this on both sides of the vehicle.

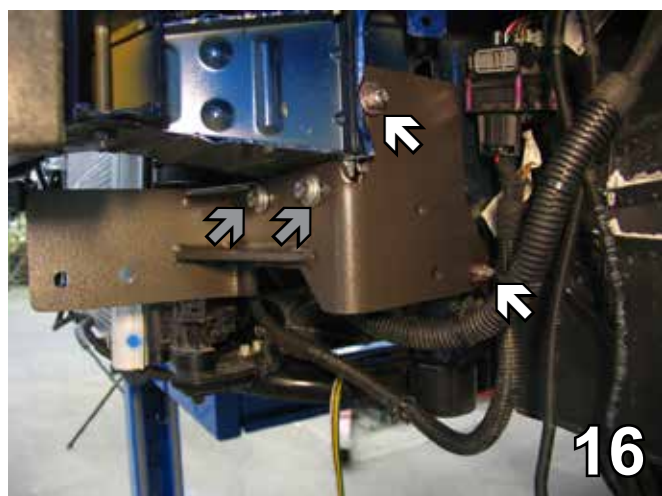

16. On the driver's side only, install the bracket over the top of the studs (white arrows). Tighten with a 3/8" flat washer for the top stud, 3/8" lock washers and 8MM hex nuts. On the front (gray arrows), attach 3/8" flat washers, 3/8" lock washers and 8MM bolts to the existing nuts.

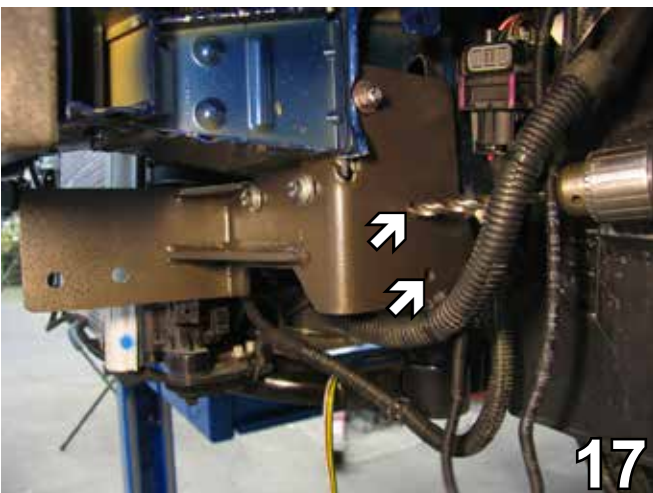

17. Using the baseplate as a template, drill the two additional holes on the side with the 13/32" drill bit. Insert 3/8"x 1 1/4" hex bolts with Loctite Red into the drilled holes, tighten with 3/8" lock washers and 3/8" hex nuts on the back side.

When using power drills be aware of the dangers of torque and drill bit length.

BX3333
2008-09 Saturn Astra
Installation Instructions



18. Loosely bolt the baseplate cross member piece to the end plates with 1/2" x 1 1/4" hex bolts and 1/2" lock washers. Be sure it is level with the vehicle and clamp to the passenger's side.



19. On the passenger side, using the baseplate as a template, drill all three holes with the 13/32" drill bit. Insert into the bottom two holes (white arrows) 3/8" x 1 1/4" hex bolts with Loctite Red, tighten with 3/8" lock washers and 3/8" hex nuts. Insert a 2" hex bolt with 3/8" lock washer using Loctite Red into the top hole (gray arrow) and tighten with 1" nut plate. Tighten the baseplate to the end plates.



20. Attach the permanent baseplate safety cables to the provided convenience link on the baseplate (see grey arrow). The photo above shows the recommended installation of the cables to frame of vehicle (see white arrow). Additional options may interfere with suggested mounting; in this case secure the cables to a solid piece of the frame as described in the instructions included with the permanent baseplate safety cables. Be sure the safety cables do not rub against any hoses or moving parts. Do this to both sides of the vehicle.

BE SURE TO USE LOCTITE® RED ON ALL BOLTS BEFORE TIGHTENING. TIGHTEN ALL BOLTS ACCORDING TO THE TORQUE CHART ON THE FRONT PAGE OF THESE INSTRUCTIONS OR ON PAGE 3 OF THE BASEPLATE TOWING GENERAL INSTRUCTIONS.

Be sure that ALL electrical connections are plugged in properly and functioning BEFORE Installing the fascia.

21. Reinstall the washer reservoir, reconnect hoses, replug connectors and reinstall the fascia.

BX3333

2008-09 Saturn Astra

Installation Instructions

Install the tow bar and safety cables according to the instructions provided in their packages. When demonstrating this to the customer, be sure to include all the contents and packages.

Do **NOT** substitute other devices if the tow bar pins and clips are misplaced.

DEALER or INSTALLER:

Be certain the user receives the instruction sheets for their products.

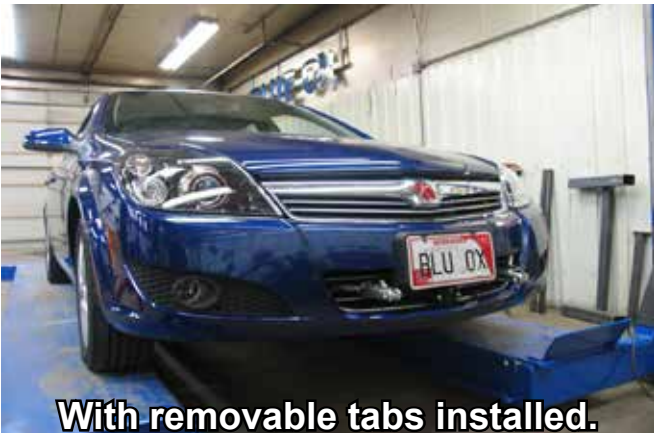

Without removable tabs installed.

If the baseplate is in an accident, it must be replaced. DO NOT use it again! An accident can cause unseen damage and using it again could result in more damage or serious injury. DO NOT use the baseplate if it is damaged or missing parts.

General Information

1. It is the owner's responsibility to inspect all towing equipment for cracked welds, missing or worn parts and loose bolts before each towing trip. Be sure to use Loctite® Red on all bolts and tighten to the recommended specifications.
2. It is the owner's responsibility to hook up all towing equipment per manufacturer's instructions/ recommendations.
3. Remove the attachment tabs when not in use (if applicable).

Notice To Baseplate Installer

1. It is YOUR responsibility to watch for:

- Oil cooler and air conditioner lines
- Electrical wires and hoses
- Missing parts or attaching points on the frame

** If the baseplate is improperly installed and is against a wire or hose, it could cause fluid leaks or electrical shorts some time after the actual baseplate installation.

Permanent Baseplate Safety Cable Installation

Permanent baseplate safety cables are strongly recommended when towing a vehicle with a tow bar. The principle function of the permanent baseplate safety cables is to prevent the towed vehicle from breaking loose in the event the connection between the frame of the towed vehicle and the baseplate fails or becomes disconnected. The cables must be connected from the baseplate to the frame rail or cross member of the vehicle's frame. The illustrations below show the possible arrangements recommended by Blue Ox®. Each permanent baseplate safety cable must have an adequate weight rating for the towing system. The weight rating of the two (2) cables together will not qualify.

Do not mount the permanent baseplate safety cables against wires, hoses or brake lines.

These permanent baseplate safety cables should remain installed as long as the baseplate is installed on the vehicle. Permanent baseplate safety cables are to be used in conjunction with, and NOT a replacement for legally required safety cables attaching the towed vehicle to the towing vehicle.

OPTION #1

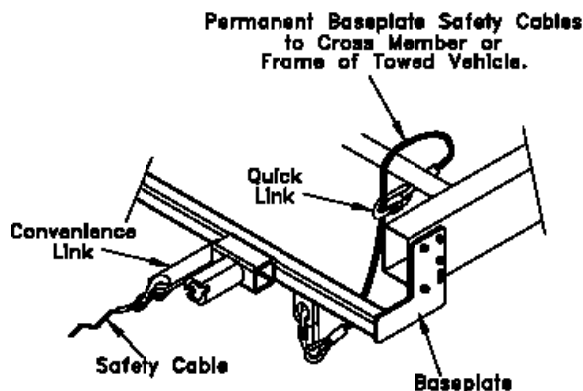

OPTION #2

