



BX3329

2007-09 Saturn Aura Installation Instructions

Please read BOTH these Installation Instructions and the General Towing Instructions before attempting to install or operate this equipment.

1. Blue Ox® towing products and accessories are intended to be installed by Blue Ox® Dealers who are familiar with our products and have the equipment and knowledge to do “it work”.
2. Many Blue Ox® Baseplates are designed to use existing holes and hardware to mount the baseplate to the towed vehicle. Even though bolts are there, do not assume they are adequate for baseplate mounting. Always use hardware supplied in the hardware kit or existing hardware specified in the Baseplate Installation Instructions.

Attachment Tab Height: 13-1/4”
Attachment Tab Width: 20”

Bolt Torque Specifications
Torque in Foot-Pounds per Metric Bolts

| Bolt Size | Grade 8.8 | Grade 10.9 |
|-----------|-----------|------------|
| 6MM | 6 | 8 |
| 8MM | 16 | 22 |
| 10MM | 31 | 40 |
| 12MM | 54 | 70 |
| 14MM | 89 | 117 |



Bolt Torque Specifications
Torque in Foot-Pounds per Inch Bolts

| Bolt Size | Grade 5 | Grade 8 |
|-----------|---------|---------|
| 1/4” | 10 | 14 |
| 5/16” | 19 | 29 |
| 3/8” | 33 | 47 |
| 7/16” | 54 | 78 |
| 1/2” | 78 | 119 |
| 5/8” | 154 | 230 |

Reference your vehicle owner’s manual for manufacturer’s towing specifications.

WARNING

Failure to read and follow these instructions could result in separation of the towed vehicle from the tow bar, causing property damage, loss of towed vehicle, personal injury or death.

BX3329

2007-09 Saturn Aura Installation Instructions

Parts List

| Ref. No. | Qty. | Part # | Description |
|----------|------|----------|---|
| 1 | 1 | 61-6328 | Weldment, Base Plate, BX3329 |
| 2 | 3 | 61-5208 | 3/8" Nut Plate, with Wire |
| 3 | 7 | 201-0368 | 3/8-16 x 1 1/4" Bolt, Grd. 5, ZP |
| 4 | 7 | 203-0010 | 3/8" Lock Washer, ZP |
| 5 | 4 | 202-0003 | 3/8-16 Hex Nut, ZP |
| 6 | 1 | 201-0655 | 6MM-1 x 30MM Hex Bolt, Grd 8.8, ZP |
| 7 | 1 | 203-0008 | 1/4" Lock Washer, ZP |
| 8 | 1 | 203-0001 | 1/4" Flat Washer, ZP |
| 9 | 2 | 201-0979 | #12-14 x 1" Self Drilling Screw, ZP |
| 10 | 2 | 201-0192 | #10-32 x 1/2" Slot, Rd. Hd. Screw |
| 11 | 2 | 203-0054 | #10 Lock Washer, ZP |
| 12 | 2 | 202-0047 | #10-32 Hex Nut, ZP |
| 13 | 2 | 101-5822 | Adapter, 4 Way Connector |
| 14 | 2 | 62-3468 | Attachment, Assembly, SF/SB (R) |
| | 1 | 201-0654 | #10-16 X 1 Self Drilling Screw |
| | 2 | 290-0437 | Cap Plugs, Black (Not Shown) |
| | 2 | 226-0046 | Permanent BP Safety Cables, 36", CL III (Not Shown) |
| | 2 | 229-0359 | 3/8" Quick Link, ZP (Not Shown) |

Tools Required

| | |
|------------------|----------------------|
| Loctite® RED | Vice Grips |
| 7MM Socket | Phillips Screwdriver |
| 10MM Socket | Utility Knife |
| 9/16" Socket | Flat Screwdriver |
| 13/32" Drill Bit | Hack Saw Blade |
| 1/4" Drill Bit | Tape Measure |

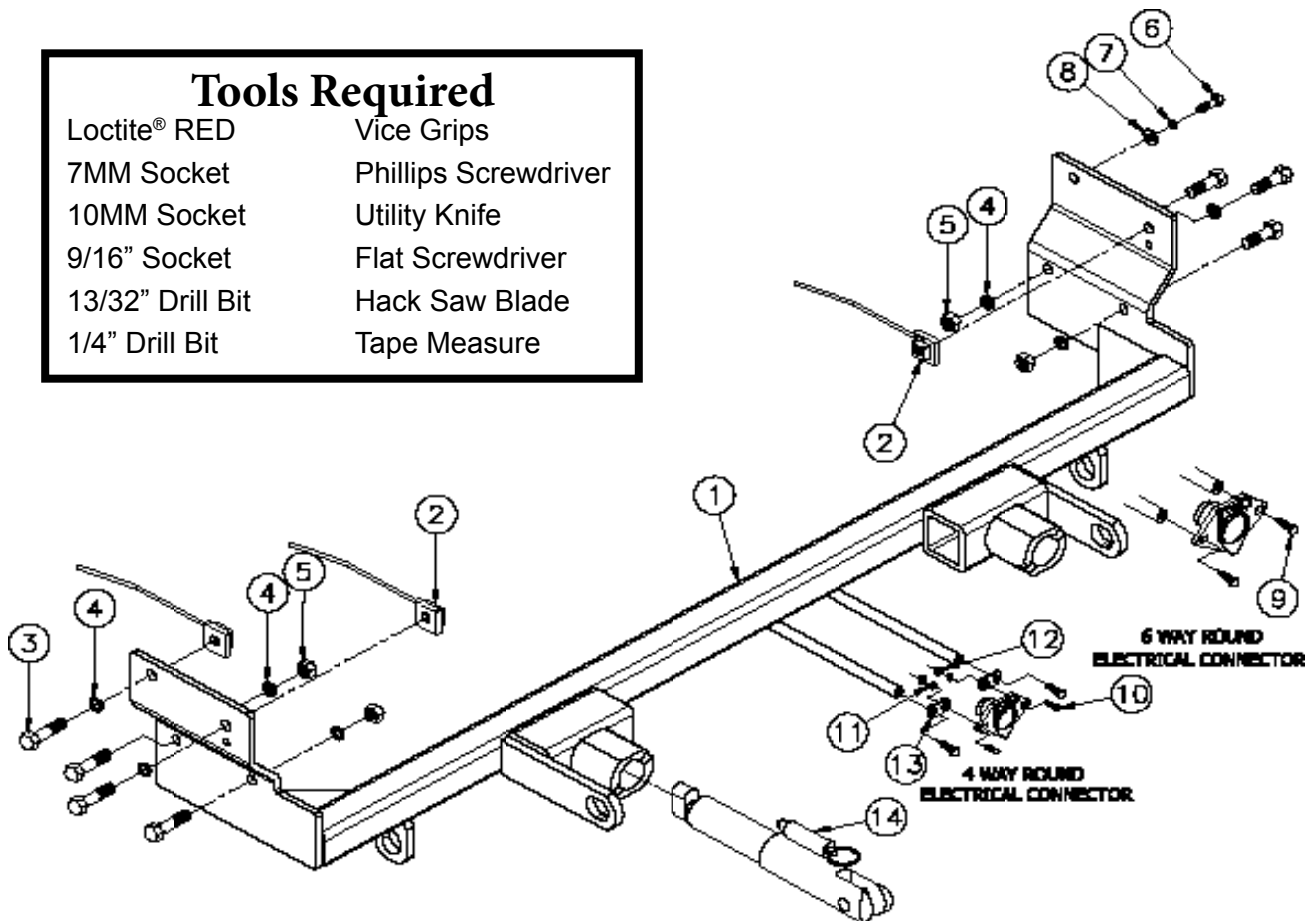

Important:

Use only genuine factory replacement parts on your baseplate. Do **NOT** substitute homemade or non-typical parts. If a bolt is lost or in need of replacement, for your safety and the preservation of your baseplate, be sure to use a replacement bolt of the same grade (In most cases it will be Grade 5, please reference the parts list above). Replacement parts may be ordered through your nearest Blue Ox® Dealer or Distributor.

BX3329

2007-09 Saturn Aura

Installation Instructions

Attachment Tabs:

Motorhome mount tow bars are recommended for use with this baseplate. Due to the design of the removable tabs, the RangeFinder II, Adventurer and Ambassador tow bars can not be used. The Acclaim tow bar may be used, but will not fold and store on the front of the vehicle. Adapters, except the BX8833 and BX88151, can not be used with this baseplate.

Installation Notes: The radiator cover, fascia, fascia support, horn bracket, air baffle, air dams and belly pan are removed for installation. Trimming of fascia, fascia support, air dams and the grille style is required. Drilling is required.

The dimensional variations between otherwise identical vehicles can be considerable. While the baseplate was designed for easy installation, it may be necessary to tailor the baseplate slightly to compensate for auto manufacturer's tolerances. These minor adjustments may include filing a hole slightly, bending electrical rods, and/or bending end plates.

The BX8869 Bulb and Socket Wiring Kit is recommended for this vehicle.



Installation Instructions



1. On top of the radiator cover, remove five (5) metric bolts using the 10MM socket. Set bolts aside to be reinstalled later.

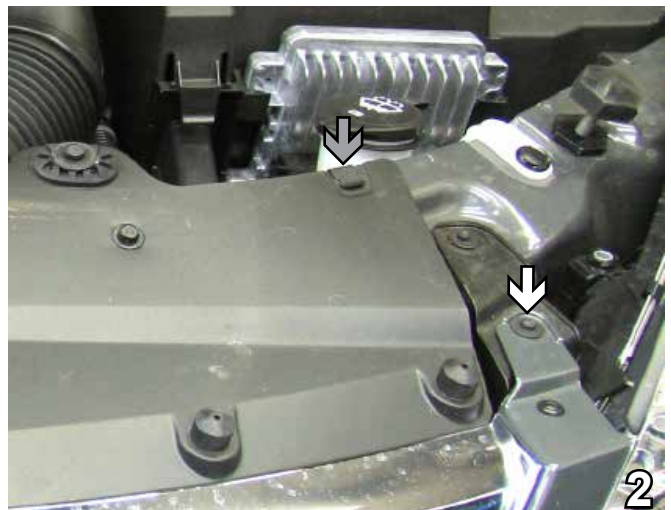

2. Using the 7MM socket, remove one (1) metric bolt from the top corner of fascia (see white arrow). On the top corner of radiator cover, remove one (1) clip (see grey arrow) using the flat screwdriver. Do this to both sides of the vehicle. Pull radiator cover forward to remove. Set bolts, clips and radiator cover aside to be reinstalled later.

BX3329
2007-09 Saturn Aura
Installation Instructions



3. On outside edge of wheel well, remove three (3) christmas tree pushpins. Do this to both sides of the vehicle. Set pushpins aside to be reinstalled later.



4. Push wheel well cover aside to remove one metric bolt using the 10MM socket. Do this to both sides of the vehicle. Set bolts aside to be reinstalled later.



5. Using the 7MM socket, remove four (4) metric bolts from inside front edge of fascia. Do this to both sides of the vehicle. Pull fascia forward to remove. Set bolts and fascia aside to be reinstalled later.



6. Remove two (2) christmas tree pushpins (see white arrows) and one (1) regular pushpin (see grey arrow) from the lower corner of belly pan. Do this to both sides of the vehicle. Set pushpins aside to be reinstalled later.

BX3329
2007-09 Saturn Aura
Installation Instructions



7. Remove two (2) pushpins from bottom of belly pan. Pull belly pan forward to remove. Set pushpins and belly pan aside to be reinstalled later.



8. On the driver's side, disconnect electrical from the horn. Using the 10MM socket, remove one (1) metric bolt from the horn bracket. Set bolt and horn bracket aside to be reinstalled later.



9. On the passenger's side, remove one (1) pushpin from the air baffle. Set pushpin aside to be reinstalled later.



10. On the passenger's side, remove one (1) pushpin between the air baffle and the wheel well. Pull air baffle down to remove. Set pushpin and air baffle aside to be reinstalled later.

BX3329
2007-09 Saturn Aura
Installation Instructions

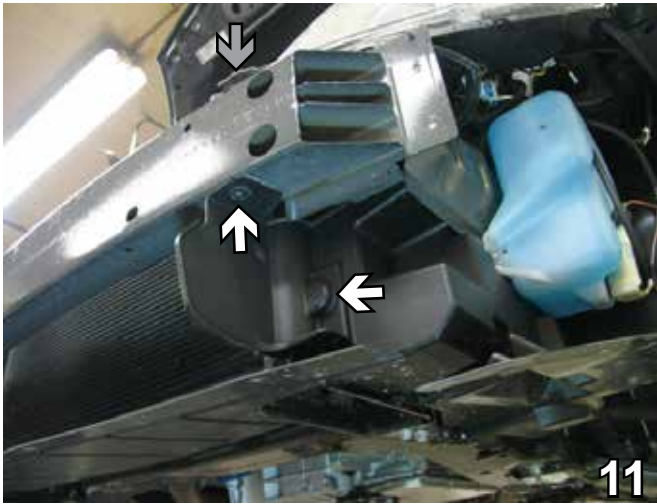

11. Remove one (1) pushpin from the air dam and one (1) from the bottom of metal bumper (see white arrows). Remove one (1) pushpin from top of metal bumper (see grey arrow). Pull air dam forward to remove. Do this to both sides of the vehicle. Set pushpins and air dams aside to be reinstalled later.



12. Lay fascia face down on a smooth, flat surface. Press in to release clip on the side of fascia support (see white arrow). Do this to both sides of fascia support. Press back to release clip on center of fascia support (see grey arrow). Pull fascia support to remove.

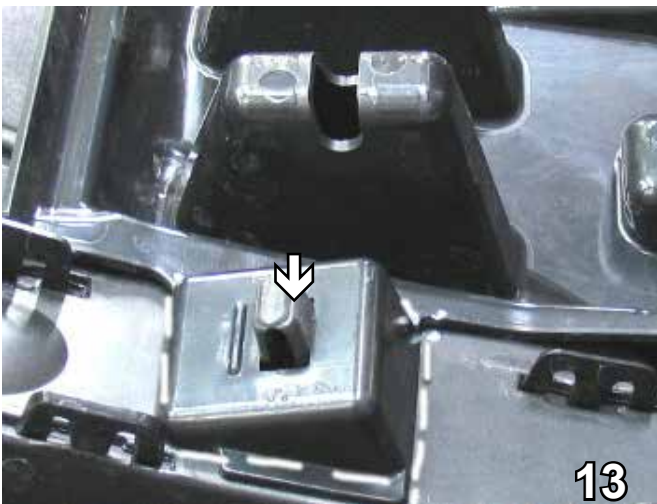

13. After removing fascia support, use the utility knife to remove the clip on both corners of fascia support.



14. Using the utility knife, remove the tab from the back corner of the fascia. Do this to both sides of vehicle.

BX3329
2007-09 Saturn Aura
Installation Instructions



15. On the driver's side, align the upper back hole of the baseplate with the existing horn bracket hole and clamp in place with the vise grips. Using the baseplate as a template, drill the three (3) remaining holes into the frame using the 13/32" drill bit.



16. Install 3/8"-16 x 1-1/4" hex bolts with 3/8" lock washers and 3/8"-16 hex nuts to lower two (2) holes.



17. On the driver's side, insert 3/8" nut plate through opening in the bottom of the frame rail and align to the upper front hole (see white arrow). Install 3/8"-16 x 1-1/4" hex bolt with 3/8" lock washers and tighten to nut plate. Reinstall horn bracket to upper back hole using 6MM hex bolt, 1/4" lock washer and 1/4" flat washer (see grey arrow). Trim excess nut plate wire.



18. On the passenger's side, align the upper front baseplate hole with the existing air baffle hole and clamp in place with the vise grips. Using the baseplate as a template, drill four (4) holes into the frame using the 13/32" drill bit.

BX3329
2007-09 Saturn Aura
Installation Instructions



19. On the passenger's side, insert 3/8" nut plates through opening in the bottom of frame rail and align to the upper two (2) holes (see white arrows). Install 3/8"-16 x 1-1/4" hex bolts with 3/8" lock washers and tighten to nut plates. Install 3/8"-16 x 1 1/4" hex bolts with 3/8" lock washers and 3/8"-16 hex nuts to the lower two holes (see grey arrows). Trim excess nut plate wires.



20. Mark the passenger's side of the air dam from the back portion of lip diagonally to the bend and down 3 inches around the contour of the air dam mold. Then mark straight down from the air dam tab three inches and horizontally back to the air dam contour and trim this area with the utility knife.



21. On the passenger's side upper rear of the air dam, use the utility knife to make a 1" horizontal cut level with the opening next to the air dam then trim vertically to remove this portion of the air dam.



22. On the passenger's side of the air dam, just behind the tab, mark 3" down and 2" horizontally. Then mark upwards, following the contour of the air dam, to the top of the air dam and trim away this area with the utility knife.

BX3329
2007-09 Saturn Aura
Installation Instructions



23. On the driver's side, just behind air dam tab, cut down 3". Then, cut horizontally toward rear of air dam approximately 2". Cut upwards to the top, following the contour of the air dam.



24. On the driver's side, approximately 1" from the top of the air dam, cut horizontally from the front of the air dam to the back.



25. Align the fascia to its original position and, using the hack saw blade, trim necessary openings in the grille style for the attachment tabs. Do this to both sides of the vehicle.



26. Attach the permanent baseplate safety cables to the provided convenience link on the baseplate (see grey arrow). The photo above shows the recommended installation of the permanent baseplate safety cables to frame of the vehicle (see white arrow). If the vehicle has additional options, not shown above, which interfere with mounting the permanent baseplate safety cables, secure the cable to a solid piece of the vehicle's frame as described in the instructions included with the permanent baseplate safety cables.

BX3329
2007-09 Saturn Aura
Installation Instructions

27. Reinstall air dams, air baffle, belly pan, fascia, radiator cover, pushpins and bolts.

Install the tow bar and safety cables according to the instructions provided in their packages. When demonstrating this to the customer, be sure to include all the contents and packages.

Do **NOT** substitute other devices if the tow bar pins and clips are misplaced.



Be sure that **ALL** electrical connections are plugged in properly and functioning **BEFORE** installing the fascia.



Shown without removable tabs installed.



Shown with removable tabs installed.

General Information

1. It is the owner's responsibility to inspect all towing equipment for cracked welds, missing or worn parts and loose bolts before each towing trip. Be sure to use Loctite® Red on all bolts and tighten to the recommended specifications.
2. It is the owner's responsibility to hook up all towing equipment per manufacturer's instructions/ recommendations.
3. Remove the attachment tabs when not in use (if applicable).

Notice To Baseplate Installer

1. It is YOUR responsibility to watch for:

- Oil cooler and air conditioner lines
- Electrical wires and hoses
- Missing parts or attaching points on the frame

** If the baseplate is improperly installed and is against a wire or hose, it could cause fluid leaks or electrical shorts some time after the actual baseplate installation.

Permanent Baseplate Safety Cable Installation

Permanent baseplate safety cables are strongly recommended when towing a vehicle with a tow bar. The principle function of the permanent baseplate safety cables is to prevent the towed vehicle from breaking loose in the event the connection between the frame of the towed vehicle and the baseplate fails or becomes disconnected. The cables must be connected from the baseplate to the frame rail or cross member of the vehicle's frame. The illustrations below show the possible arrangements recommended by Blue Ox®. Each permanent baseplate safety cable must have an adequate weight rating for the towing system. The weight rating of the two (2) cables together will not qualify.

Do not mount the permanent baseplate safety cables against wires, hoses or brake lines.

These permanent baseplate safety cables should remain installed as long as the baseplate is installed on the vehicle. Permanent baseplate safety cables are to be used in conjunction with, and NOT a replacement for legally required safety cables attaching the towed vehicle to the towing vehicle.

OPTION #1

Permanent Baseplate Safety Cables to Cross Member or Frame of Towed Vehicle.

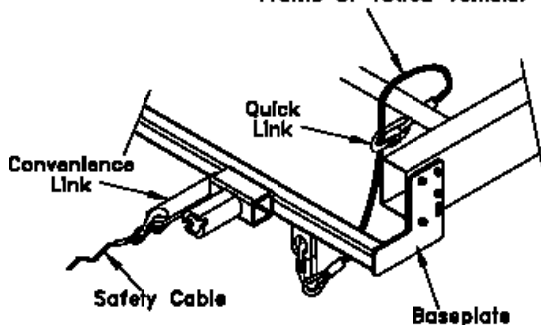

OPTION #2

Permanent Baseplate Safety Cables to Cross Member or Frame of Towed Vehicle.

