

BX3325  
2005-07 Saturn Ion  
Non Red Line  
Installation Instructions

**Please read BOTH these Installation Instructions and the General Instructions before attempting to install or operate this equipment.**

- Blue Ox® towing products and accessories are intended to be installed by Blue Ox® Dealers who are familiar with our products and have the equipment necessary and knowledge to do “fit work”.
- Many Blue Ox® Baseplates are designed to use existing holes and hardware to mount the baseplate to the towed vehicle. Even though bolts are there, do not assume they are adequate for baseplate mounting. Always use hardware supplied in the hardware kit and existing hardware specified in the Baseplate Installation Instructions.

Attachment Tab Height: 13”  
Attachment Tab Width: 24”

**Bolt Torque Specifications**  
Torque in Foot-Pounds for Metric Bolts

Bolt Size	Grade 8.8	Grade 10.9
6MM	6	8
8MM	16	22
10MM	31	40
12MM	54	70
14MM	89	117

Confirm the towability and pre-towing procedures for your vehicle with the owner’s manual or contact the vehicle’s manufacturer for specific towing procedures.

**Bolt Torque Specifications**  
Torque in Foot-Pounds for Inch Bolts

Bolt Size	Grade 5	Grade 8
1/4”	10	14
5/16”	19	29
3/8”	33	47
7/16”	54	78
1/2”	78	119
5/8”	154	230



**! WARNING**

Failure to read and follow these instructions could result in separation of the towed vehicle from the tow bar, causing property damage, loss of towed vehicle, personal injury or death.

# BX3325

## 2005-07 Saturn Ion

### Non Red Line

## Installation Instructions

### Parts List

Ref. No.	Qty.	Part #	Description
1	1	61-6102	Weldment, Baseplate, BX3325
2	6	61-5208	3/8" Nutplate, with Wire
3	2	201-0443	3/8-16 x 1" Hex Bolt, Grd. 5, ZP
4	6	201-0440	3/8-16 x 1 1/2" Hex Bolt, Grd. 5, ZP
5	8	203-0010	3/8" Lock Washer, ZP
6	2	202-0003	3/8-16 Hex Nut, ZP
7	2	201-0979	#12-14 x 1" Self Drilling Screw, ZP
8	2	201-0192	#10-32 x 1/2" Slot, Rd. Hd. Screw
9	2	203-0054	#10 Lock Washer
10	2	202-0047	#10-32 Hex Nut
11	2	101-5822	Adapter, 4 Way Connector
12	2	62-3469	Attachment, Assembly, SF/LB (R)
E	1		Existing bolt on the passenger's side for the air baffle
	2	226-0046	Baseplate Safety Cable, 36" CL III (Not Shown)
	4	229-0359	Quicklink, 3/8, ZP (Not Shown)
	2	290-0437	Cap Plug, Black, (Not Shown)

### Tools Required

7MM Socket	Utility Knife
10MM Socket	Reciprocating Saw
9/16" Socket	Loctite® RED
13/32" Drill Bit	

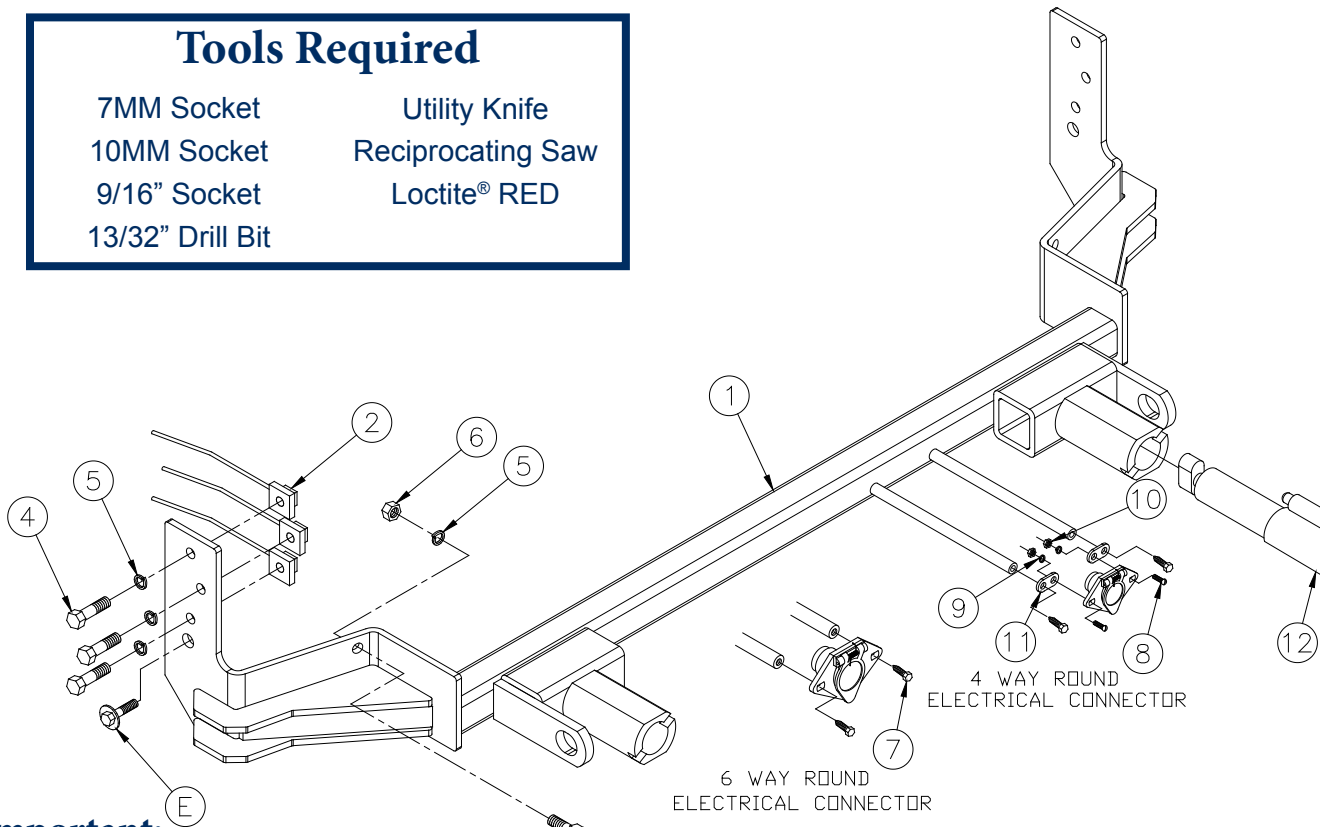

### Important:

Use only genuine factory replacement parts on your baseplate. Do NOT substitute homemade or non-typical parts. If a bolt is lost or in need of replacement, for your safety and the preservation of your baseplate, be sure to use a replacement bolt of the same grade (in most cases it will be Grade 5, please reference the parts list above).

BX3325

# 2005-07 Saturn Ion

Non Red Line

## Installation Instructions

### Attachment Tabs:

Due to the design of the removable tabs, the RangeFinder II tow bar can not be used. Adapters, except for the BX8833 and the BX88151, can not be used with this baseplate.

### Instructions:

The front fascia and horn bracket are removed and reinstalled during the baseplate installation. Drilling is required. Trimming of the air dam and fascia is required. The bumper bracket webbing is removed.

The dimensional variations between otherwise identical vehicles can be considerable. While the baseplate was designed for easy installation, it may be necessary to tailor the baseplate slightly to compensate for auto manufacturer's tolerances. These minor adjustments may include filing a hole slightly, bending electrical rods or bending end plates.

The BX8869 Bulb and Socket Wiring Kit is recommended for this vehicle.



Possible location for the BX8869 Bulb and Socket Kit.

Handling of some cosmetic parts when installing this product may require the use of protective covers, rags, specialty tools, etc. to prevent damage.

### Installation Instructions:



1. Using a 7MM socket, remove four metric bolts from the top side of the fascia. Set the bolts aside to be reinstalled later.



2. Using a 7MM socket, remove one metric bolt from just forward of the front tire on the edge of the wheel well cover. Set bolt aside to be reinstalled later. Remove two pushpins from the same location. Set pushpins aside to be reinstalled later. Do this to both sides of the vehicle.

BX3325  
2005-07 Saturn Ion  
Non Red Line  
Installation Instructions



3. Remove four pushpins from the bottom edge of the fascia, just forward of the front tire. Set the pushpins aside to be reinstalled later. Do this to both sides of the vehicle. Pull fascia's upper corners out to the side of the vehicle and straight forward. Set the fascia aside carefully to be reinstalled later.



4. Remove one pushpin from the styrofoam bumper. Set styrofoam bumper and pushpin aside to be reinstalled later.



5. Using the utility knife, remove the upper portion of the air dam with the tab. Do this to both sides of the vehicle.
6. Using the 10MM socket, remove four metric bolts from the metal bumper. Do this to both sides of the vehicle and set the bumper aside to be reinstalled later. Measure and mark  $2\frac{3}{4}$ " up from the bottom edge of the bumper bracket webbing and approximately 2" in to the frame edge on the back side of the webbing. Using the reciprocating saw, remove this portion. Do this to both sides of the vehicle.

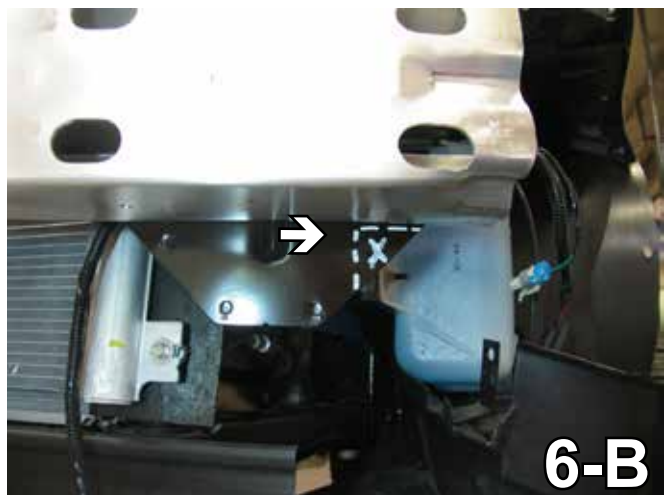
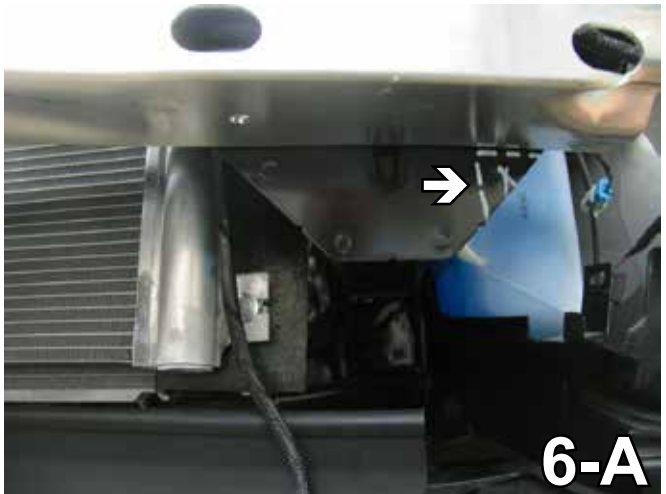

BX3325  
2005-07 Saturn Ion  
Non Red Line  
Installation Instructions



7. Using a 10MM socket, remove one metric bolt from the air baffle on the passenger's side. Set the bolt aside to be reinstalled later.



8. Using a 10MM socket, remove one metric bolt from the horn bracket on the driver's side. Unplug the electrical connections. Set the horn bracket and the metric bolt aside to be reinstalled later.

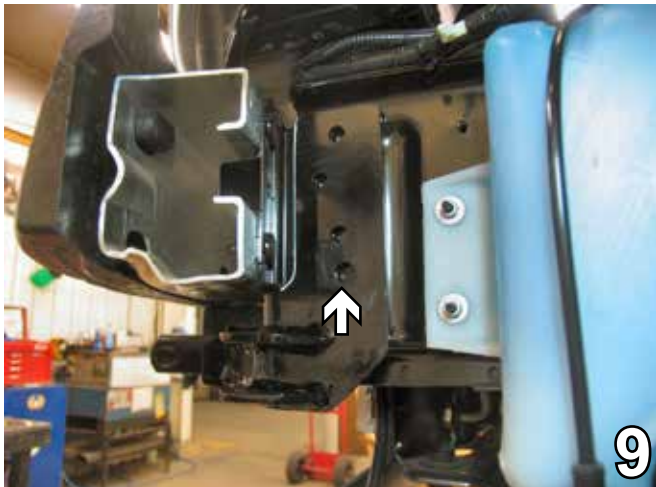

9. Slide the baseplate onto the frame end as far forward as possible. Align the larger lower hole in baseplate end plate existing hole for the air baffle on the passenger's side and tighten the existing metric bolt to hold the baseplate in place. Clamp the both sides of lower baseplate to the lower frame webbing with the vise grip. Using the baseplate as a template, drill the three top holes with the 13/32 drill bit. Do this to both sides of the vehicle. Insert the 3/8" nutplate into the square opening on the bottom of the frame rail to align with the drilled holes, tighten the 3/8" hex bolts and lock washers. Do this to both sides of the vehicle.

When using power drills be aware of the dangers of torque and drill bit length.



10. Using the baseplate as a template, drill the hole just below the metal bumper with the 13/32" drill bit. Do this to both sides of the vehicle. Insert the 3/8" hex bolt into the drilled hole, tighten the 3/8" hex nut and lock washer on the back side of the bumper bracket webbing. Do this to both sides of the vehicle.

**BE SURE TO USE LOCTITE® RED ON ALL BOLTS BEFORE TIGHTENING. TIGHTEN ALL BOLTS ACCORDING TO THE TORQUE CHART ON THE FRONT PAGE OF THESE INSTRUCTIONS OR ON PAGE 3 OF THE BASEPLATE TOWING GENERAL INSTRUCTIONS.**

BX3325  
2005-07 Saturn Ion  
Non Red Line  
**Installation Instructions**

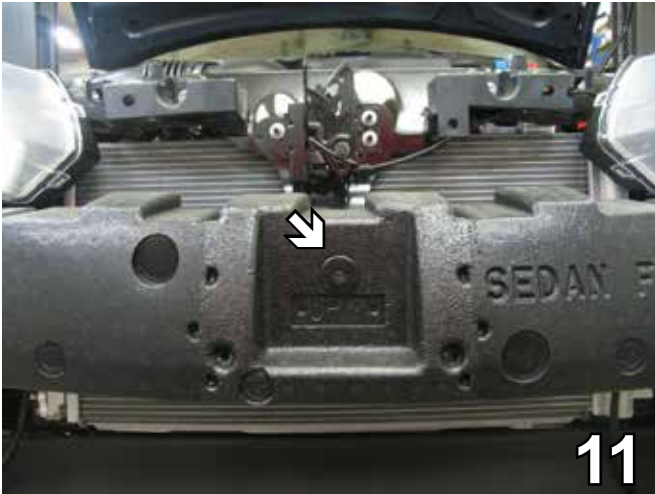

11. Reinstall the horn bracket on the driver's side. Reinstall the metal bumper and styrofoam to their original positions.

**Be sure that ALL electrical connections are plugged in properly and functioning BEFORE Installing the fascia.**

Install the tow bar and safety cables according to the instructions provided in their packages. When demonstrating this to the customer, be sure to include all the contents and packages.

Do **NOT** substitute other devices if the tow bar pins and clips are misplaced.

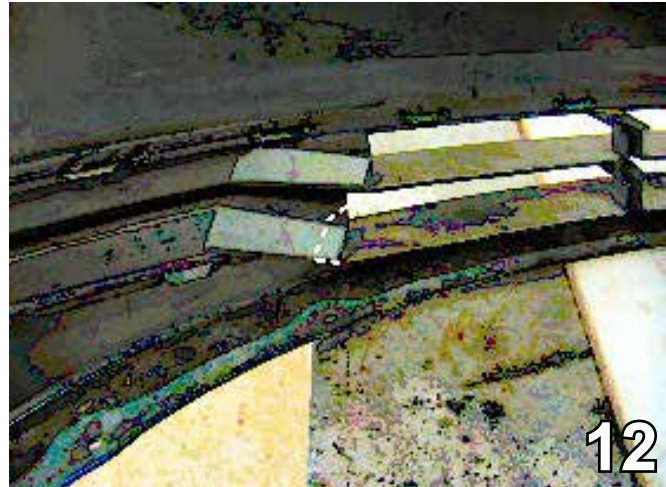

12. Using the utility knife, cut 3/4" deep into the back edge of the fascia to open the area for baseplate installation. Do this to both sides of the vehicle. NOTE: Some models may not need trimming of the back fascia. Slide the fascia on the vehicle to verify. Reinstall the fascia as close to the original position as possible and trim the lower lip of the fascia's rib (12-A). It is not necessary to completely cut out the horizontal rib. Be sure all of the electrical connections are plugged in to their proper locations for the horn (some models may have fog lights) before installing the fascia.

BX3325

# 2005-07 Saturn Ion

## Non Red Line

### Installation Instructions

**DEALER or INSTALLER:**

Be certain the user receives the instruction sheets for their products.



**With removable tabs installed.**

### 2005 Saturn Ion



### 2007 Saturn Ion Quad Coupe

If the baseplate is in an accident, it must be replaced. DO NOT use it again! An accident can cause unseen damage and using it again could result in more damage or serious injury. DO NOT use the baseplate if it is damaged or missing parts.



# General Information

1. It is the owner's responsibility to inspect all towing equipment for cracked welds, missing or worn parts and loose bolts before each towing trip. Be sure to use Loctite® Red on all bolts and tighten to the recommended specifications.
2. It is the owner's responsibility to hook up all towing equipment per manufacturer's instructions/recommendations.
3. Remove the attachment tabs when not in use (if applicable).

## Notice To Baseplate Installer

1. It is YOUR responsibility to watch for:

- Oil cooler and air conditioner lines
- Electrical wires and hoses
- Missing parts or attaching points on the frame

\*\* If the baseplate is improperly installed and is against a wire or hose, it could cause fluid leaks or electrical shorts some time after the actual baseplate installation.

## Permanent Baseplate Safety Cable Installation

Permanent baseplate safety cables are strongly recommended when towing a vehicle with a tow bar. The principle function of the permanent baseplate safety cables is to prevent the towed vehicle from breaking loose in the event the connection between the frame of the towed vehicle and the baseplate fails or becomes disconnected. The cables must be connected from the baseplate to the frame rail or cross member of the vehicle's frame. The illustrations below show the possible arrangements recommended by Blue Ox®. Each permanent baseplate safety cable must have an adequate weight rating for the towing system. The weight rating of the two (2) cables together will not qualify.

***Do not mount the permanent baseplate safety cables against wires, hoses or brake lines.***

These permanent baseplate safety cables should remain installed as long as the baseplate is installed on the vehicle. Permanent baseplate safety cables are to be used in conjunction with, and NOT a replacement for legally required safety cables attaching the towed vehicle to the towing vehicle.

### OPTION #1

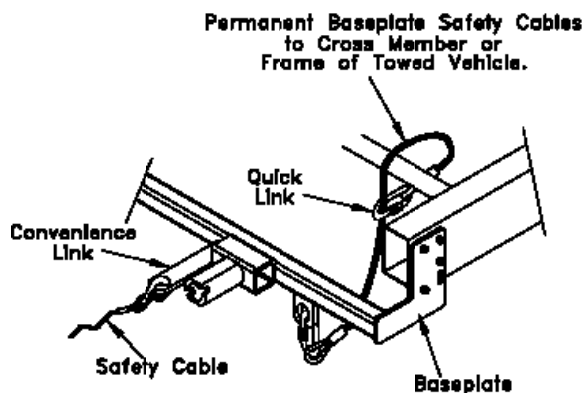

### OPTION #2

