



BX2724

2012-15 Kia Rio Hatchback Installation Instructions

Attachment Tab Height: 15"

Attachment Tab Width: 24"

Please read BOTH these Installation Instructions and the General Instructions prior to installing or operating this equipment.

1. Blue Ox® towing products and accessories are intended to be installed by Blue Ox® Dealers who are familiar with our products and have the equipment and knowledge necessary to do "it work".
2. Many Blue Ox® baseplates are designed to use existing holes and hardware to mount the baseplate to the towed vehicle. Even though bolts are there, do not assume they are adequate for baseplate mounting. Always use the hardware supplied in the hardware kit and existing hardware as specified in the installation instructions.

Bolt Torque Specifications

Torque in Foot-Pounds for Inch Bolts

Bolt Size	Grade 5	Grade 8
1/4"	10	14
5/16"	19	29
3/8"	33	47
7/16"	54	78
1/2"	78	119
5/8"	154	230
3/4"	257	380



Bolt Torque Specifications

Torque in Foot-Pounds for Metric Bolts

Bolt Size	Grade 8.8	Grade 10.9
6MM	6	8
8MM	16	22
10MM	31	40
12MM	54	70
14MM	89	117
16MM	161	230
18MM	222	318

Reference your vehicle owner's manual for manufacturer's towing specifications.



WARNING

Failure to read and follow these instructions could result in separation of the towed vehicle from the tow bar, causing property damage, loss of towed vehicle, personal injury or death.

BX2724
2012-15 Kia Rio Hatchback
Installation Instructions

Removable Tabs: Use only with motorhome mount tow bars or the BX8833 or BX88151 adapters. Removable tabs with only one hole will not attach to car mount tow bars or other adapters. The Acclaim may only be used with removable tab baseplates that have 23" or greater spaced tabs. The Adventurer may only be used with baseplates that have 16" – 36" spaced removable tabs. The Ambassador may only be used with 24" spaced removable tabs.

Instruction Notes: The fascia, horn and temperature sensor are removed for the baseplate installation. Some drilling and trimming is required.

The dimensional variations between otherwise identical vehicles can be considerable. While the baseplate was designed for easy installation, it may be necessary to tailor the baseplate slightly to compensate for vehicle manufacturer's tolerances. These minor adjustments may include filing a hole slightly, bending electrical rods or bending end plates.

The BX8869 Tail Light Wiring Kit is recommended for this vehicle.

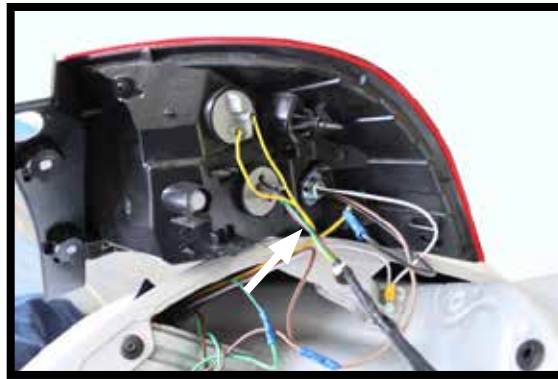

Drill a 1" hole to install the 3 wire
automotive socket.

NOTICE

- Handling of some cosmetic parts when installing this product may require the use of protective covers, rags, specialty tools, etc. to prevent damage.
- When using power drills be aware of the dangers of torque and drill bit length.
- When using a reciprocating saw be aware of objects behind the cutting surface.
- Use a good quality paint to spray cut edges of frame to prevent rusting.
- Be sure that **ALL** electrical connections are plugged in and accessories are functioning properly before reinstalling the fascia.
- The baseplate is computer tested to your vehicle's GVWR, exceeding this weight will void the manufacturer's warranty.
- Be sure to use Loctite® Red on all bolts before tightening. Tighten all bolts according to the torque chart provided.
- Dealer or installer be certain the user receives these instruction sheet.
- If the baseplate is in an accident, it must be replaced. **DO NOT** use it again! An accident can cause unseen damage and using it again could result in more damage or serious injury. **DO NOT** use the baseplate if it is damaged or missing parts.

BX2724
2012-15 Kia Rio Hatchback
Installation Instructions

- Tools Required**
- 10MM Socket
 - 12MM Socket
 - 13MM Socket
 - 9/16" Socket
 - Large Vise Grip
 - Torque Wrench
 - Tape Measure
 - Drill
 - 13/32" Drill Bit
 - Loctite® Red
 - Flat Screwdriver
 - Phillips Screwdriver

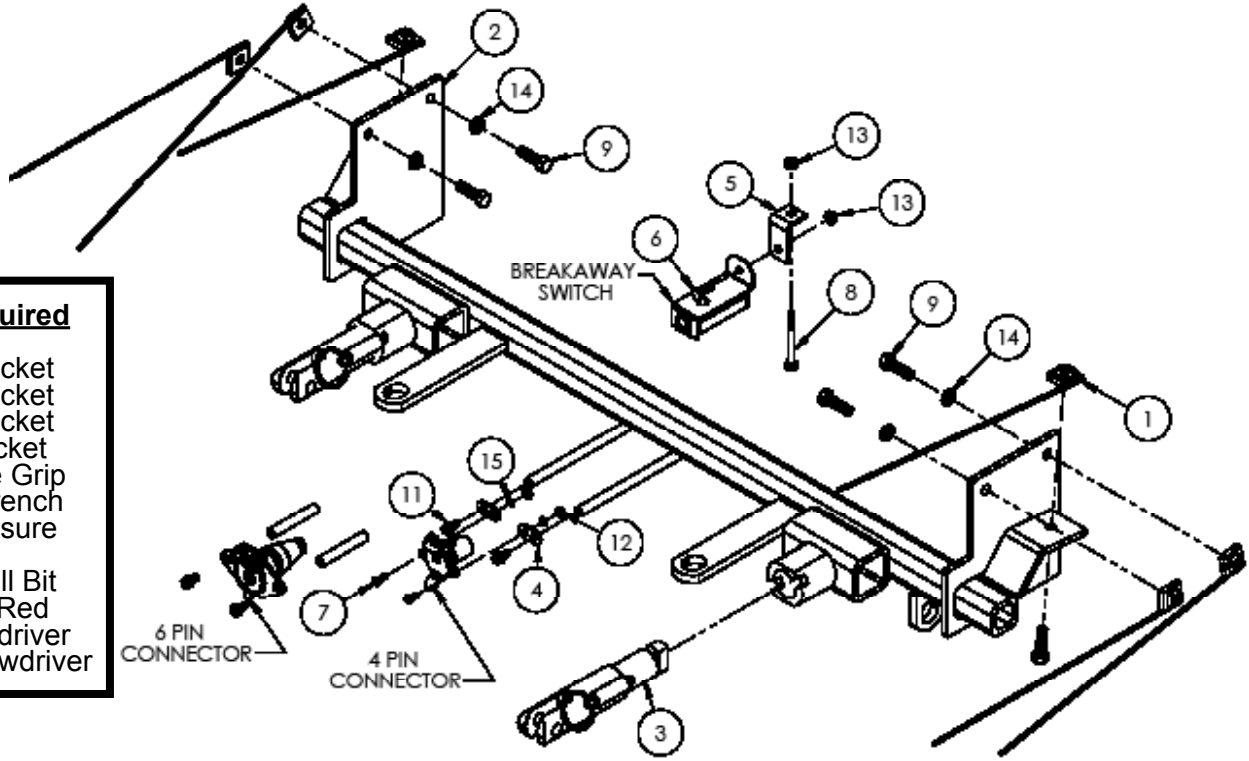

Item No.	Part No.	Description	Qty.
1.....	61-5208.....	3/8"-16 Nut Plate.....	6
2.....	61-7045.....	BX2724 Baseplate.....	1
3.....	62-3468.....	Attachment Tab Assembly with Hole.....	2
4.....	101-5822.....	4 Way Connector Adapter.....	2
5.....	102-7355.....	Breakaway Bracket.....	1
6.....	201-0050.....	1/4"-20 x 3/4" Hex Head Bolt, Grade 5, ZP.....	2
7.....	201-0192.....	#10-32 1/2" Round Slotted Head Screw.....	2
8.....	201-0321.....	1/4"-20 x 2-1/2" Hex Head Bolt, Grade 5, ZP.....	1
9.....	201-0368.....	3/8"-16 x 1-1/4" Hex Head Bolt, Grade 5, ZP.....	6
10.....	201-0446.....	8MM-1.25 x 30MM Hex Head Bolt, Grade 8.8, ZP.....	2
11.....	201-0979.....	#12-14 x 1" Self Drilling Screw, ZP.....	2
12.....	202-0047.....	#10-32 Hex Nut.....	2
13.....	202-0102.....	1/4"-20 Hex Nylon Nut, ZP.....	3
14.....	203-0010.....	3/8" Lock Washer, ZP.....	6
15.....	203-0054.....	#10 Lock Washer, ZP.....	2
16.....	203-0102.....	8MM Lock Washer, ZP.....	1
17.....	203-0107.....	8MM Flat Washer, ZP.....	1
18.....	226-0046(not shown).....	Class III Safety Cables.....	2
19.....	229-0359(not shown).....	3/8" Quicklink, ZP.....	4
20.....	290-0437(not shown).....	Black Cap Plug Receiver.....	1

Important:

Use only genuine factory replacement parts on your baseplate. Do **NOT** substitute homemade or non-typical parts. If a bolt is lost or in need of replacement, for your safety and the preservation of your baseplate, be sure to use a replacement bolt of the same grade (In most cases it will be Grade 5, please reference the parts list above). Replacement parts may be ordered through your nearest Blue Ox® Dealer or Distributor. Failing to follow and/or altering these installation instructions in either installation or required equipment will void the manufacturer's warranty. Towing behind a non-motorized vehicle will void the warranty.

BX2724
2012-15 Kia Rio Hatchback
Installation Instructions

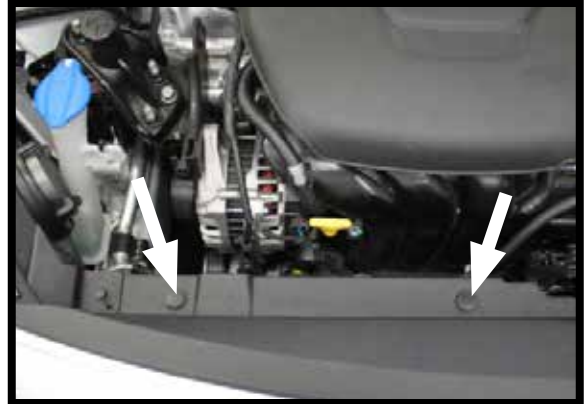
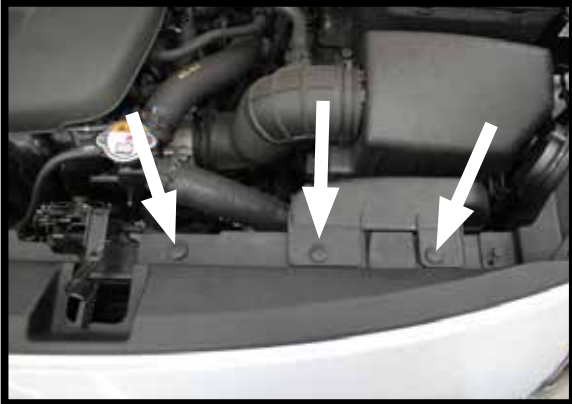

1. Remove the five (5) push pins that are located in the front area, underneath the hood. There are three (3) push pins located on the outer edge of the driver side and two (2) on the outer edge of the passenger side.



2. Once the push pins have been removed, pop the plastic covers off. Underneath the covers there are four (4) additional push pins, two (2) per side, that must be removed.

BX2724
2012-15 Kia Rio Hatchback
Installation Instructions



3. On the front tire wheel well remove the bolt using a 10MM socket. Do this on both sides.



4. Remove the two (2) push pins located under the bumper towards the outer edge. Do this on both sides.



5. Pull the front fascia away from the front of the vehicle. Gently pry the fascia away from under the headlight area.

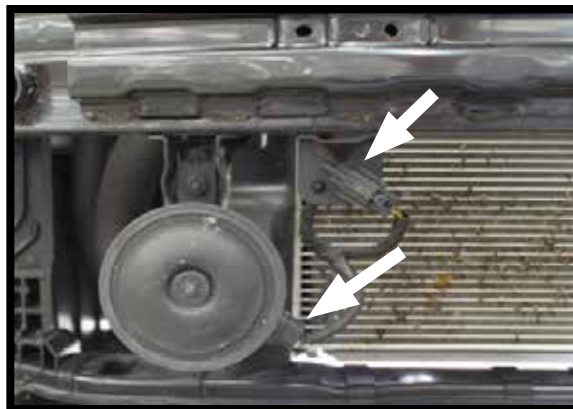

6. Unplug the horn and temperature sensor. They will be repositioned after the baseplate has been completely installed.

BX2724
2012-15 Kia Rio Hatchback
Installation Instructions



7. To remove the front bumper, unclip the wiring harness and place it out of the way. Next, remove the bumper using a 12MM socket for the two (2) outer bolts and 10MM socket for the center bolt on the top of the bumper frame bracket. On the bottom of the bracket there are two (2) 12MM bolts that need to be removed. Do this on both sides of the vehicle.



8. On the passenger side ONLY there is a plastic tab. Remove this tab by pulling upward. It will not be reinstalled.



9. Place the bumper upside down on a flat, steady surface.



10. Remove the horn bracket located on the passenger side. The horn will be relocated after the baseplate has been installed.

BX2724
2012-15 Kia Rio Hatchback
Installation Instructions



11. Place baseplate onto bumper frame. The back edge of the baseplate should be flush with the bumper frame bracket. Using a 13/32" drill bit and the baseplate as a template, drill out the holes. Do this on both sides.

Insert the 3/8"-16 hex head bolts, 3/8" lock washers and 3/8"-16 nut plates. To make the installation of the nut plates easier, tip the baseplate forward slightly.



12. Reattach the bumper frame using the existing hardware except for the top bolt on the bottom section of the bumper bracket. The supplied 8MM bolt replaces the bolt that was removed as the attached washer would not allow the bolt to be started.

BX2724
2012-15 Kia Rio Hatchback
Installation Instructions

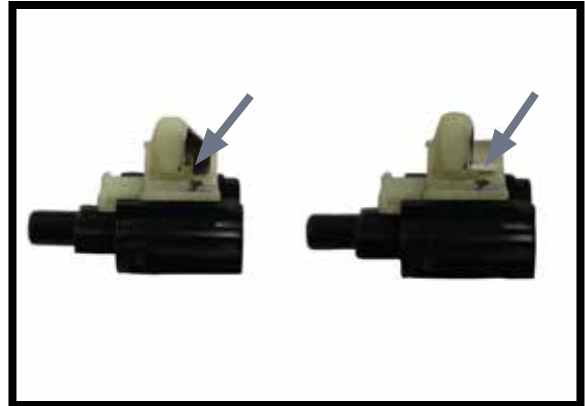
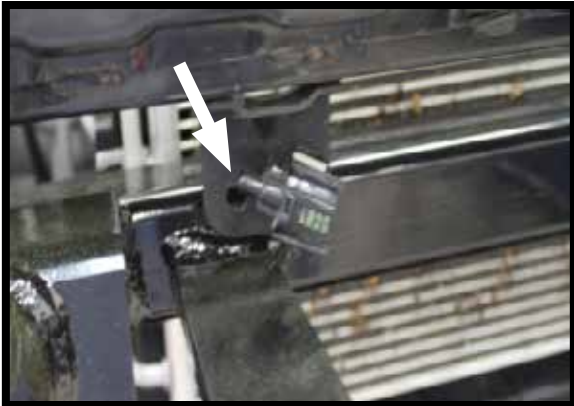

13. The temperature sensor will need to be relocated from the slot to the adjacent hole. In order for the sensor to fit you must trim the attachment bracket. The horn will be placed in the slot that the temperature sensor was originally located in.



14. After the front fascia has been reinstalled trim the grill to allow ample room for the attachment tabs. Do this on both sides.



15. Attach the permanent baseplate safety cables to the provided convenience link on the baseplate. The photo above shows the recommended installation of the cables to frame of vehicle. Additional options may interfere with suggested mounting; in this case, secure the cables to a solid piece of the frame as described in the instructions included with the permanent baseplate safety cables. Be sure the safety cables do not rub against any hoses or moving parts. Do this on **BOTH** sides of the vehicle.

16. In order to install the breakaway bracket you must drill thru the existing hole in the bumper which is located next to the connector rods.

General Information

1. It is the owner's responsibility to inspect all towing equipment for cracked welds, missing or worn parts and loose bolts before each towing trip. Be sure to use Loctite® Red on all bolts and tighten to the recommended specifications.
2. It is the owner's responsibility to hook up all towing equipment per manufacturer's instructions/ recommendations.
3. Remove the attachment tabs when not in use (if applicable).

Notice To Baseplate Installer

1. It is YOUR responsibility to watch for:

- Oil cooler and air conditioner lines
- Electrical wires and hoses
- Missing parts or attaching points on the frame

** If the baseplate is improperly installed and is against a wire or hose, it could cause fluid leaks or electrical shorts some time after the actual baseplate installation.

Permanent Baseplate Safety Cable Installation

Permanent baseplate safety cables are strongly recommended when towing a vehicle with a tow bar. The principle function of the permanent baseplate safety cables is to prevent the towed vehicle from breaking loose in the event the connection between the frame of the towed vehicle and the baseplate fails or becomes disconnected. The cables must be connected from the baseplate to the frame rail or cross member of the vehicle's frame. The illustrations below show the possible arrangements recommended by Blue Ox®. Each permanent baseplate safety cable must have an adequate weight rating for the towing system. The weight rating of the two (2) cables together will not qualify.

Do not mount the permanent baseplate safety cables against wires, hoses or brake lines.

These permanent baseplate safety cables should remain installed as long as the baseplate is installed on the vehicle. Permanent baseplate safety cables are to be used in conjunction with, and NOT a replacement for legally required safety cables attaching the towed vehicle to the towing vehicle.

OPTION #1

Permanent Baseplate Safety Cables to Cross Member or Frame of Towed Vehicle.

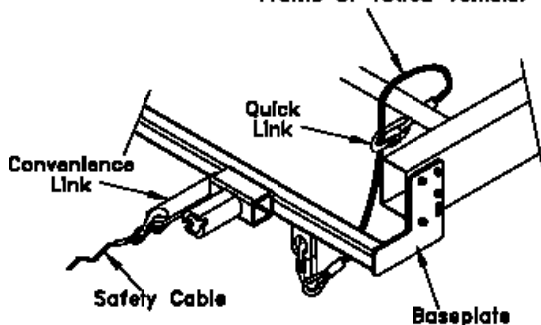

OPTION #2

Permanent Baseplate Safety Cables to Cross Member or Frame of Towed Vehicle.

