



BX2603
 2008-09 Ford Fusion SEL
 Installation Instructions

Please read BOTH these Installation Instructions and the General Towing Instructions before attempting to install or operate this equipment.

- Blue Ox® towing products and accessories are intended to be installed by Blue Ox® Dealers who are familiar with our products and have the equipment and knowledge to do “fit work”.
- Many Blue Ox® Baseplates are designed to use existing holes and hardware to mount the baseplate to the towed vehicle. Even though bolts are there, do not assume they are adequate for baseplate mounting. Always use hardware supplied in the hardware kit or existing hardware specified in the Baseplate Installation Instructions.

Attachment Tab Height: 13 1/2”
 Attachment Tab Width: 22”

Bolt Torque Specifications
 Torque in Foot-Pounds per Metric Bolts

Bolt Size	Grade 8.8	Grade 10.9
6MM	6	8
8MM	16	22
10MM	31	40
12MM	54	70
14MM	89	117

Confirm the towability and pre-towing procedures for your vehicle with the owner’s manual or contact the vehicle’s manufacturer for specific towing procedures.

Bolt Torque Specifications
 Torque in Foot-Pounds per Inch Bolts

Bolt Size	Grade 5	Grade 8
1/4”	10	14
5/16”	19	29
3/8”	33	47
7/16”	54	78
1/2”	78	119
5/8”	154	230



! WARNING
 Failure to read and follow these instructions could result in separation of the towed vehicle from the tow bar, causing property damage, loss of towed vehicle, personal injury or death.

BX2603

2008-09 Ford Fusion SEL

Installation Instructions

Parts List

Ref. No.	Qty.	Part #	Description
1	1	61-6554	Weldment, Baseplate, WLDM'T, BX2603
2	6	61-5208	3/8-16 Nut Plate, with 14" Wire
3	2	61-5558	1/2-13 Nut Plate, with 14" Wire
4	6	201-0440	3/8-16 x 1 1/2" Bolt, Grd. 5, ZP
5	6	203-0010	3/8" Lock Washer, ZP
6	2	201-0051	1/2-13 x 1 1/2" Bolt, Grd. 5, ZP
7	2	203-0012	1/2" Lock Washer, ZP
8	2	201-0979	#12-14 x 1" Self Drilling Screw, ZP
9	2	201-0192	#10-32 x 1/2" Slot, Rd. Hd. Screw
10	2	203-0054	#10 Lock Washer
11	2	202-0047	#10-32 Hex Nut
12	2	101-5822	Adapter, 4 Way Connector
13	2	62-3468	Attachment, Assembly, SF/SB (R)
	2	226-0046	Baseplate Safety Cable, 36" CL III (Not Shown)
	2	229-0359	Quicklink, 3/8, ZP (Not Shown)
	2	290-0437	Cap Plug, Black (Not Shown)

Tools Required

- 7MM Socket
- 10MM Socket
- 13MM Socket/Wrench
- 9/16" Socket/Wrench
- 3/4" Socket/Wrench
- T25 Torx Socket
- Large Vise Grips
- Reciprocating Saw
- Flat Screwdriver
- Utility Knife
- 13/32" Drill Bit
- 1/2" Drill Bit
- Loctite® RED

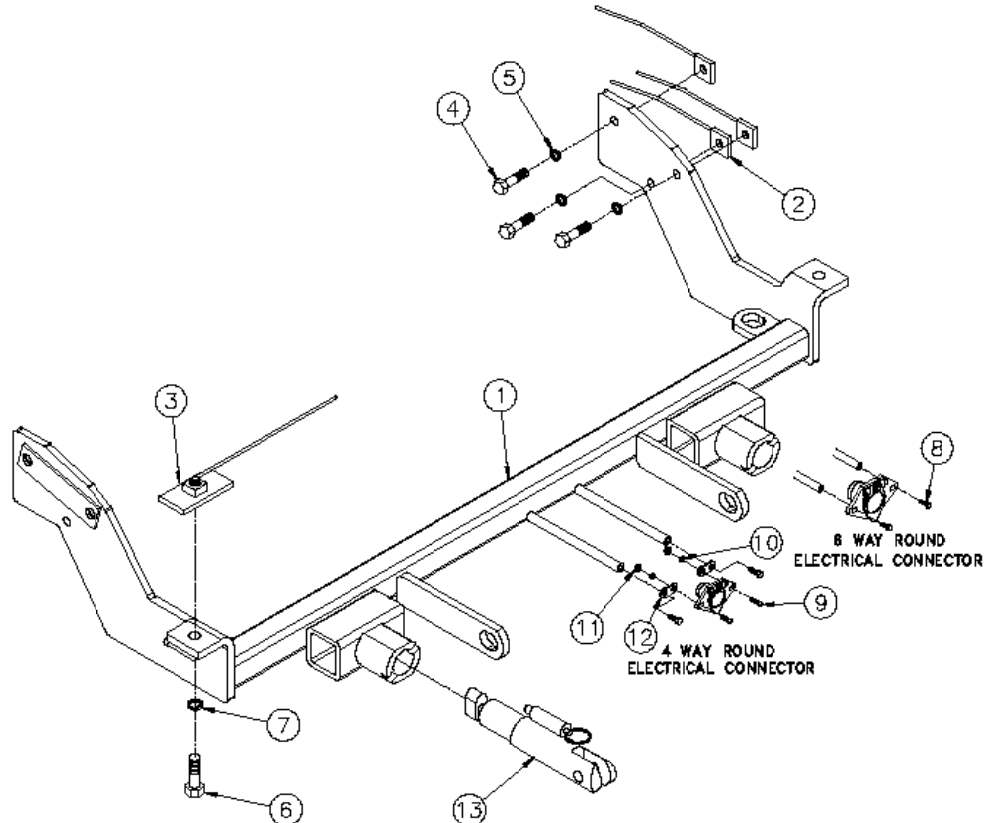

Important:

Use only genuine factory replacement parts on your baseplate. Do **NOT** substitute homemade or non-typical parts. If a bolt is lost or in need of replacement, for your safety and the preservation of your baseplate, be sure to use a replacement bolt of the same grade (In most cases it will be Grade 5, please reference the parts list above). Replacement parts may be ordered through your nearest Blue Ox® Dealer or Distributor.

BX2603

2008-09 Ford Fusion SEL

Installation Instructions

Attachment Tabs:

Motorhome mount tow bars are recommended for use with this baseplate. Due to the design of the removable tabs, the RangeFinderII, Adventurer and Ambassador tow bars can not be used. The Acclaim tow bar may be used, but will not fold and store on the front of the vehicle. Adapters, except the BX8833 and BX88151, can not be used with this baseplate.

Installation Notes: The front fascia, belly pan, metal bumper, plastic bumper cover, air dams, headlights, and fan modulator are removed and replaced during installation. Drilling is required. The grille must be trimmed. The air dams will not be reinstalled.

The dimensional variations between otherwise identical vehicles can be considerable. While the baseplate was designed for easy installation, it may be necessary to tailor the baseplate slightly to compensate for auto manufacturer's tolerances. These minor adjustments may include filing a hole slightly, bending electrical rods, and/ or bending end plates.

The BX8869 Bulb and Socket Wiring Kit is recommended for this vehicle.



Installation Instructions:



1. Using the 10mm socket, remove two metric bolts from the top corners of the grille (white arrows). Remove two pushpins from the top of the grille (gray arrows). Set bolts and pushpins aside to be reinstalled later.



2. Just forward of the front tire, inside the wheel well, remove three pushpins. Do this to both sides of the vehicle. Set pushpins aside to be reinstalled later.

BX2603
2008-09 Ford Fusion SEL
Installation Instructions



3. Using the 7mm socket, remove three metric bolts from the bottom edge of the fascia just forward of the front tire. Do this to both sides of the vehicle. Set bolts aside to be reinstalled later.



4. Using the 7mm socket, remove four metric bolts from underneath the center of the fascia. Pull fascia forward to remove it. Set bolts and fascia carefully aside to be reinstalled later.



5. Using the 7mm socket, remove two metric bolts from the corners of the belly pan, one on each side (white arrows). Remove four pushpins from the bottom of the fascia. Pull outer belly pan down to remove. Set bolts and pushpins aside to be reinstalled later.

BX2603
2008-09 Ford Fusion SEL
Installation Instructions

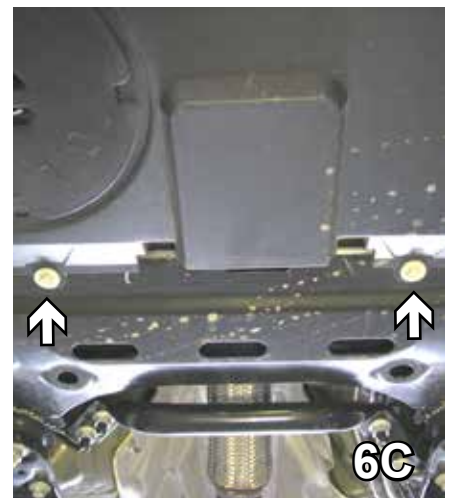
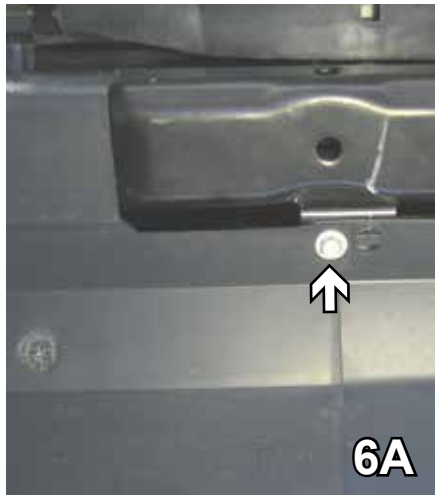

6. Using the 10mm socket, remove seven metric bolts from underneath the plastic belly pan. Pull belly pan down to remove. Set the belly pan and bolts aside to be reinstalled later.

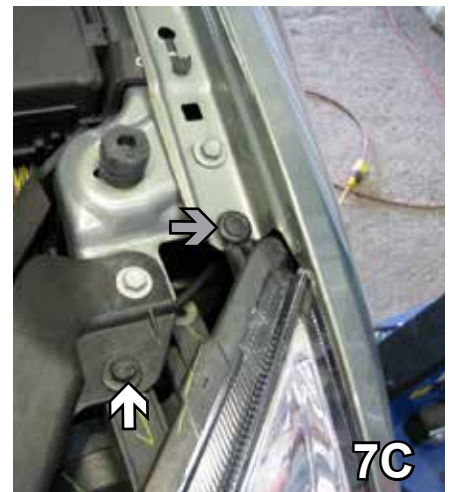

7. Using the 10mm socket, remove four metric bolts from the headlight, one on each side (see 5A & B), two on the top (see 5B & 5C) and remove a push pin on the top (gray arrow). Set the headlight up on top without unplugging. Do this to both sides of the vehicle. Set bolts and push pins aside to be reinstalled later.

BX2603
2008-09 Ford Fusion SEL
Installation Instructions

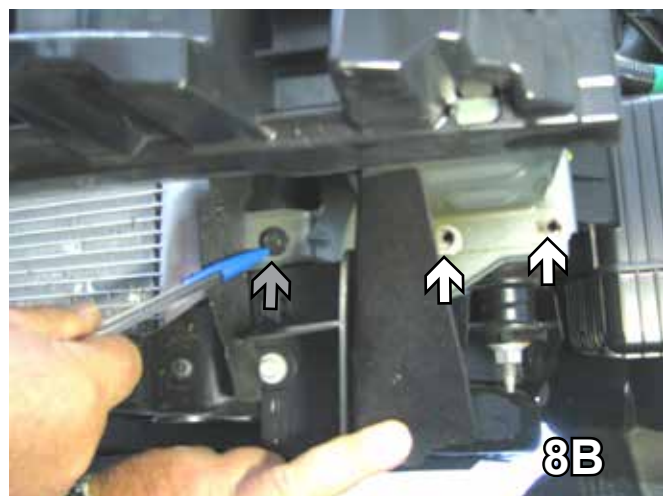
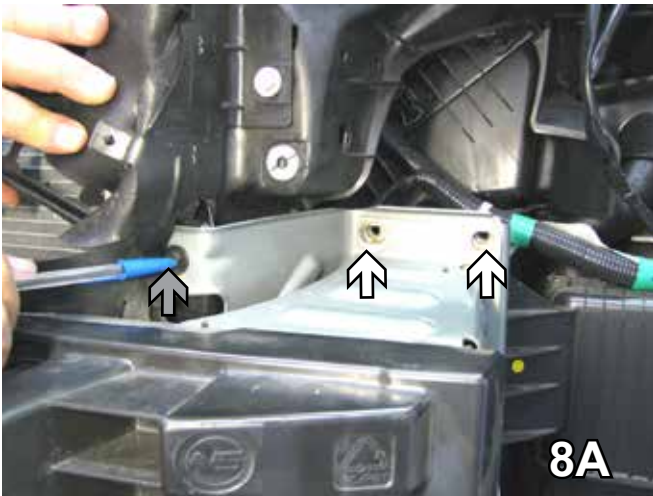

8. Using the 13mm socket, remove four metric bolts from the bumper bracket, two on the top and two on the bottom (see white arrows). Using the 10mm socket, remove two metric bolts from the side of the bumper bracket (see grey arrows). Do this to both sides of the vehicle. Pull the metal bumper forward to remove. Set bolts and metal bumper aside to be reinstalled later.

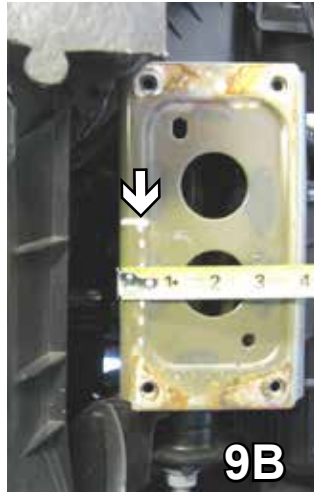
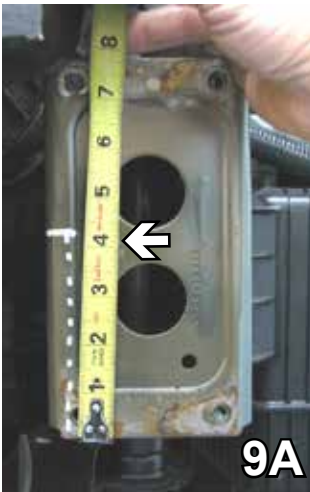

9. Mark the rectangular area on the frame rail end end cap, 1/2" from the inside edge and up 4" from the bottom of the frame rail. Trim away the area using the reciprocating saw. This will clear the area for baseplate installation. Photos show driver's side.
10. Using the 10mm socket, remove the metric bolt securing the air dam to the radiator support. Do this to both sides of the vehicle. Discard the bolts and air dams as they will not be reinstalled.

BX2603
2008-09 Ford Fusion SEL
Installation Instructions

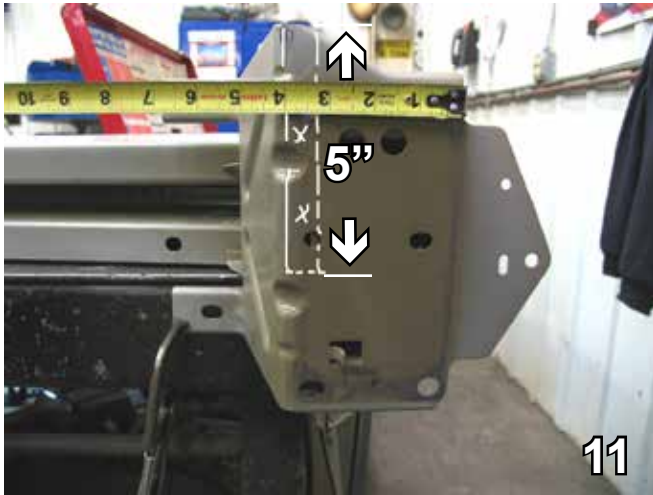

11. Set bumper up side down on the work bench. On the back side of the metal bumper bracket, measure and mark a rectangle, 5" down from the bottom side of the bumper bracket and between the 3 1/4" mark in from the outside edge of the bumper to the 4" mark, making it 3/4" wide. *Note: To make cutting easier, flip the metal bumper over as shown in the photo above. Driver's side is shown in the photo.*



12. Using the T25 Torx socket, remove the bolt in the cut away area above the fan modulator, behind the radiator on the driver's side. Move the fan modulator out of the way to clear the area for baseplate drilling. Set the bolt aside to be reinstalled later.



13. On the bottom side of the bumper plastic, measure and mark a rectangle 2 1/2" wide on the raised molding 2 1/2" from the outside edge of the plastic and 1" high. Trim away the area with the utility knife to open for baseplate installation. Do this to both sides of the plastic. Driver's side is shown in the photo.



14. Reinstall the metal bumper. Install only two bolts on each side to hold the bumper in place because it will be removed again. It is not necessary to insert the plastic to the front of the bumper at this time.

BX2603
2008-09 Ford Fusion SEL
Installation Instructions



15. Slide the baseplate up through notches in the bumper bracket until flush with the bottom of the metal bumper. Insure the baseplate is level. Clamp baseplate in place to bumper and fascia with the large vise grips. Using the baseplate as a template, drill holes into the frame rail with the 13/32" drill bit. Do this to both sides of the vehicle. *Note: On passenger's side, using a drill bit shield to protect the vehicle's hoses is recommended.*



16. Remove the metal bumper. Insert the 3/8-16 nut plates into the frame rail to align with the 3/8-16 x 1 1/2" bolts, use Loctite, and tighten with the 9/16" socket. Do this to both sides of the vehicle. Remove the vise grips.

BE SURE TO USE LOCTITE® RED ON ALL BOLTS BEFORE TIGHTENING. TIGHTEN ALL BOLTS ACCORDING TO THE TORQUE CHART ON THE FRONT PAGE OF THESE INSTRUCTIONS OR ON PAGE 3 OF THE BASEPLATE TOWING GENERAL INSTRUCTIONS.



17. Reinstall metal bumper and plastic cover. Tighten all bolts completely. *Note: Due to the trimming of the bumper brackets, there will be one less 10mm bolt installed on the bottom of each bumper bracket.*

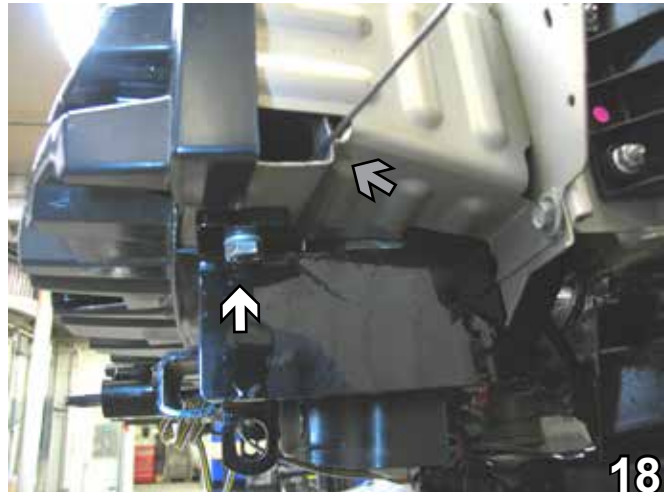

18. Using the baseplate as a template, drill into the bottom of the metal bumper using the 17/32" drill bit. Insert the 1/2-13 x 1 1/2" bolt and 1/2" lock washer (see white arrow). Insert 1/2-13 nut plate (see grey arrow) and tighten to the bolt with the 3/4" socket. Do this to both sides of the vehicle.

BX2603
2008-09 Ford Fusion SEL
Installation Instructions

19. Reinstall headlights, fan modulator and bellypan. Insure all pushpins, bolts, and electrical connections are installed.

Be sure that **ALL** electrical connections are plugged in properly and functioning **BEFORE** installing the fascia.



21. Attach the permanent baseplate safety cables to the provided convenience link on the baseplate (see grey arrow). The photo above shows the recommended installation of the permanent baseplate safety cables to frame of the vehicle (see white arrow). If the vehicle has additional options, not shown above, which interfere with mounting the permanent baseplate safety cables, secure the cable to a solid piece of the vehicle's frame as described in the instructions included with the permanent baseplate safety cables.



20. Hold the fascia up to its original location, mark and trim the grille with the utility knife as necessary for the attachment tabs to come through. The convenience links will come through the second opening from the top of grille and the electrical rods through the third opening from the top. Reinstall the fascia.

DEALER or INSTALLER:

Be certain the user receives the instruction sheets for their products.

Install the tow bar and safety cables according to the instructions provided in their packages. When demonstrating this to the customer, be sure to include all the contents and packages.

Do **NOT** substitute other devices if the tow bar pins and clips are misplaced.

BX2603
2008-09 Ford Fusion SEL
Installation Instructions



Shown without removable tabs installed.



Shown with removable tabs installed.

Customer Service Commitment

Blue Ox is committed to providing you with exceptional customer care throughout your lifetime with our products. Our team is here to assist you with any questions you may have regarding the performance of your product.

Additionally, please visit our website to see which rallies our Destination America team will be attending. For a nominal fee, our service technician will service your towing system to ensure it's in proper working condition. Also as a commitment to our customers, should you visit our factory you can stay at our full service Blue Ox campground at no charge along with enjoying a factory tour.

Again thank you for being our customer and for the confidence you have shown in the performance of our products. It is because of customers like you we enjoy the success we have today.

General Information

1. Ensure that your product(s) are registered online. It is crucial to register your product(s) so that you may be alerted of product offerings, updates, upgrades, maintenance and safety bulletins, and/or recalls.
2. **It is the owner's responsibility to inspect all towing equipment for cracked welds, missing or worn parts and loose bolts before each towing trip.** Be sure to use Loctite® Red on all bolts and tighten to the recommended specifications.
3. **It is the owner's responsibility to hook up all towing equipment per manufacturer's instructions/ recommendations.**
4. Remove the attachment tabs when not in use (if applicable).

Notice To Baseplate Installer

1. It is YOUR responsibility to watch for:

- Oil cooler and air conditioner lines
- Electrical wires and hoses
- Missing parts or attaching points on the frame

** If the baseplate is improperly installed and is against a wire or hose, it could cause fluid leaks or electrical shorts some time after the actual baseplate installation.

Permanent Baseplate Safety Cable Installation

Permanent baseplate safety cables are strongly recommended when towing a vehicle with a tow bar. The principle function of the permanent baseplate safety cables is to prevent the towed vehicle from breaking loose in the event the connection between the frame of the towed vehicle and the baseplate fails or becomes disconnected. The cables must be connected from the baseplate to the frame rail or cross member of the vehicle's frame. The illustrations below show the possible arrangements recommended by Blue Ox®. Each permanent baseplate safety cable must have an adequate weight rating for the towing system. The weight rating of the two (2) cables together will not qualify.

Do not mount the permanent baseplate safety cables against wires, hoses or brake lines.

These permanent baseplate safety cables should remain installed as long as the baseplate is installed on the vehicle. Permanent baseplate safety cables are to be used in conjunction with, and NOT a replacement for legally required safety cables attaching the towed vehicle to the towing vehicle.

OPTION #1

Permanent Baseplate Safety Cables to Cross Member or Frame of Towed Vehicle.

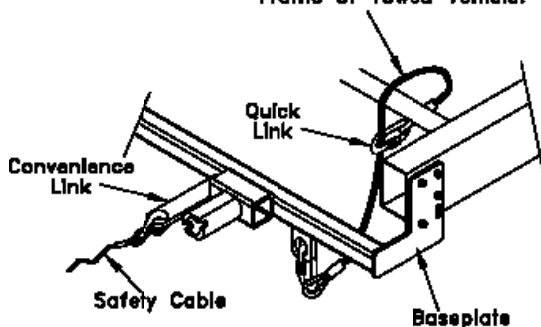

OPTION #2

Permanent Baseplate Safety Cables to Cross Member or Frame of Towed Vehicle.

