

Please read **BOTH** these Installation Instructions and the General Instructions before attempting to install or operate this equipment.

1. Blue Ox® towing products and accessories are intended to be installed by Blue Ox® Dealers who are familiar with our products and have the equipment necessary and knowledge to do "fit work".
2. Many Blue Ox® Baseplates are designed to use existing holes and hardware to mount the baseplate to the towed vehicle. Even though bolts are there, do not assume they are adequate for baseplate mounting. Always use hardware supplied in the hardware kit and existing hardware specified in the Baseplate Installation Instructions.

Attachment Tab Height: 14"

Attachment Tab Width: 24"

Bolt Torque Specifications

Torque in Foot-Pounds for Metric Bolts

Bolt Size	Grade 8.8	Grade 10.9
6MM	6	8
8MM	16	22
10MM	31	40
12MM	54	70
14MM	89	117

Confirm the towability and pre-towing procedures for your vehicle with the owner's manual or contact the vehicle's manufacturer for specific towing procedures.

Bolt Torque Specifications

Torque in Foot-Pounds for Inch Bolts

Bolt Size	Grade 5	Grade 8
1/4"	10	14
5/16"	19	29
3/8"	33	47
7/16"	54	78
1/2"	78	119
5/8"	154	230



! WARNING

Failure to read and follow these instructions could result in separation of the towed vehicle from the tow bar, causing property damage, loss of towed vehicle, personal injury or death.

BX2229 2002-05 Honda Accord

(Including LX, EX, DX)

Installation Instructions

Parts List

Ref. No.	Qty.	Part #	Description
1	1	61-5863	Weldment, Baseplate, BX2229
2	1	61-5288	Weldment, 1/2-13 DS, Nutplate
3	1	61-5289	Weldment, 1/2-13, PS, Nutplate
4	4	61-5208	Weldment, 3/8-16, Nutplate, with Wire
5	2	62-3469	Attachment Assembly, SF/LB (R)
6	4	201-0051	1/2-13 x 1 1/2" Hex Bolt, Grade 5, ZP
7	4	203-0012	1/2" Lock Washer, ZP
8	6	201-0368	3/8-16 x 1 1/4" Hex Bolt, Grade 5, ZP
9	2	203-0003	3/8" Flat Washer, ZP
10	6	203-0010	3/8" Lock Washer, ZP
11	2	202-0003	3/8-16 Hex Nut, ZP
12	2	201-0979	#12-14 x 1" Self Drilling Screw, ZP
13	2	202-0047	#10-32 Hex Nut
14	2	203-0054	#10 Lock Washer
15	2	201-0192	#10-32 x 1/2" Slot, Rd. Hd. Screw
16	2	101-5822	Adapter, 4 Way Connector
17	1	201-0655	6MM-1" x 30MM Hex Bolt, Grade 8.8, ZP
18	1	203-0008	1/4" Lock Washer, ZP
19	1	203-0001	1/4" Flat Washer, ZP
	2	226-0046	Baseplate Safety Cable, 36" CL III (Not Shown)
	2	229-0359	Quicklink, 3/8, ZP (Not Shown)
	2	290-0437	Cap Plug, Black (Not Shown)

Tools Required

8MM Socket
 10MM Socket
 12MM Socket
 13MM Socket
 13/32" Drill Bit
 Vise Grips
 LOCTITE Red

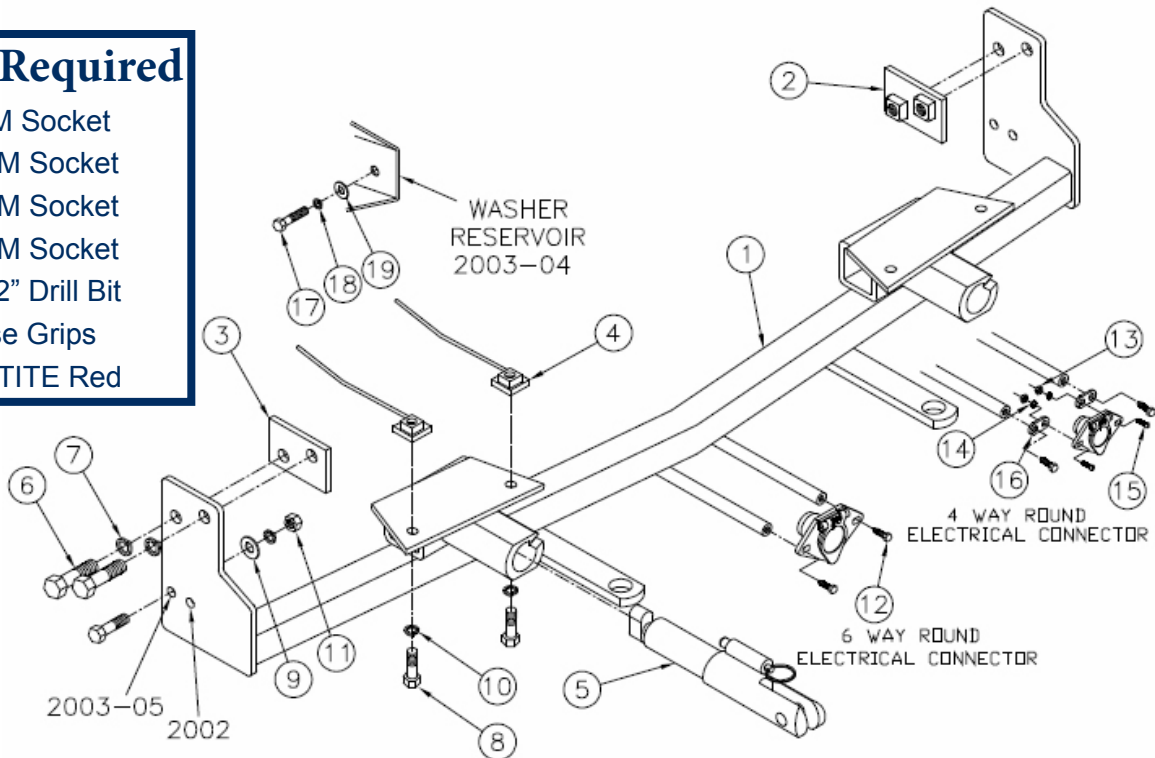

Important:

Use only genuine factory replacement parts on your baseplate. Do NOT substitute homemade or non-typical parts. If a bolt is lost or in need of replacement, for your safety and the preservation of your baseplate, be sure to use a replacement bolt of the same grade (In most cases it will be Grade 5, please reference the parts list above).

BX2229
2002-05 Honda Accord
(Including LX, EX, DX)
Installation Instructions

Removable Tabs:

Due to the design of the removable tabs, the RangeFinder II tow bar can not be used. Adapters, except for the BX8833 and the BX88151, can not be used with this baseplate.

Instructions:

The front fascia, metal bumper, and head light assemblies are removed and reinstalled for the baseplate installation. Drill is required.

The dimensional variations between otherwise identical vehicles can be considerable. While the baseplate was designed for easy installation, it may be necessary to tailor the baseplate slightly to compensate for auto manufacturer's tolerances. These minor adjustments may include filing a hole slightly, bending electrical rods or bending end plates.

The BX8869 Bulb and Socket Wiring Kit is available for this vehicle.



1. Remove two pushpins from the top side of the grille. Set the pushpins aside to be reinstalled later.



2. Using the 8MM socket, just behind the fascia's upper corner, remove one metric bolt. Set the bolt aside to be reinstalled later. Do this to both sides of the vehicle.

BX2229
2002-05 Honda Accord
(Including LX, EX, DX)
Installation Instructions



3. Using the 10MM socket, remove the metric bolt from the bottom side of the fascia corner. Set the metric bolt aside to be reinstalled later. Do this to both sides of the vehicle.



4. Remove six pushpins from the bottom side of the fascia. Set the pushpins aside to be reinstalled later.



5. Using the 10MM socket, remove five bolts under and one on the outside of the headlight assemblies, unplug and set aside to be reinstalled later. Set metric bolts aside to be reinstalled later. Do this to both sides of the vehicle.

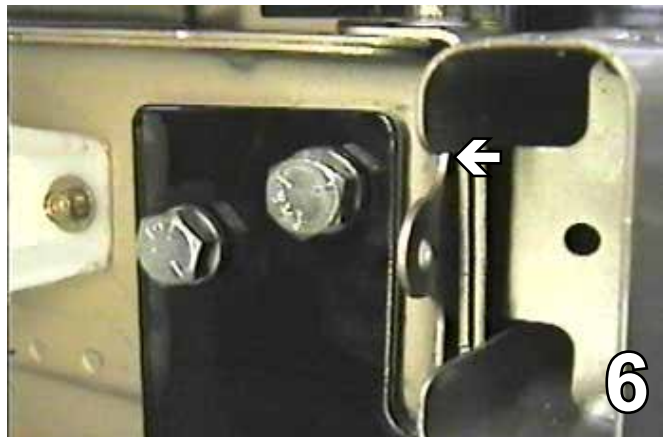

6. **2002 Models:** Hold the baseplate in place, clamp with the vise grips, and center to the bottom of the metal bumper.

2003-05 Models: Hold the baseplate sides to align with the front edge of the frame end. Mark and drill all holes into the frame using the 13/32" drill bit and the 17/32" (upper holes) drill bit. Do this to both sides of the vehicle.

BX2229
2002-05 Honda Accord
(Including LX, EX, DX)
Installation Instructions



7. Using the 12MM socket, remove metric bolts from the top and bottom of metal bumper and set metal bumper aside to be reinstalled later. Set baseplate in place with drilled holes. Insert the 3/8-16 nut plates into the frame end and start the 3/8-16 x 1 1/2" hex bolts and the 3/8" lock washers, do **NOT** tighten. Slide the metal bumper between baseplate and frame to align with existing holes. Use the 3/8" flat washer between the metal bumper and the baseplate to level as needed, vehicles may vary. Tighten the 8MM-1.25 x 30MM hex bolts, 8MM lock washers, and the 3/8" flat washers on the top side and existing bolts on the bottom side. **BE SURE TO USE LOCTITE Red on ALL bolts.**

Install the tow bar and safety cables according to the instructions included in their packages.

Do not substitute other devices if the tow bar pin and clip are lost.

DEALER OR INSTALLER: BE CERTAIN THE USER RECEIVES THE INSTRUCTION SHEETS.



8. Reinstall the metal bumper, align the 3/8-16 nutplate inside the metal bumper with the drilled 13/32" hole and tighten the 1/2" lock washer, 3/8" lock washer. for upper supports.



9. Reinstall the fascia and headlight assemblies. Some trimming may be required.

2003-04 Models: The front washer reservoir bolt plastic will need to be trimmed before the installation . Install the washer reservoir. Be sure to reconnect all electrical and fluid lines.

BX2229
2002-05 Honda Accord
(Including LX, EX, DX)
Installation Instructions



Shown with Removable Tabs Installed.



If the baseplate is in an accident, it must be replaced. DO NOT use it again! An accident can cause unseen damage and using it again could result in more damage or serious injury. DO NOT use the baseplate if it is damaged or missing parts.

General Information

1. It is the owner's responsibility to inspect all towing equipment for cracked welds, missing or worn parts and loose bolts before each towing trip. Be sure to use Loctite® Red on all bolts and tighten to the recommended specifications.
2. It is the owner's responsibility to hook up all towing equipment per manufacturer's instructions/recommendations.
3. Remove the attachment tabs when not in use (if applicable).

Notice To Baseplate Installer

1. It is YOUR responsibility to watch for:

- Oil cooler and air conditioner lines
- Electrical wires and hoses
- Missing parts or attaching points on the frame

** If the baseplate is improperly installed and is against a wire or hose, it could cause fluid leaks or electrical shorts some time after the actual baseplate installation.

Permanent Baseplate Safety Cable Installation

Permanent baseplate safety cables are strongly recommended when towing a vehicle with a tow bar. The principle function of the permanent baseplate safety cables is to prevent the towed vehicle from breaking loose in the event the connection between the frame of the towed vehicle and the baseplate fails or becomes disconnected. The cables must be connected from the baseplate to the frame rail or cross member of the vehicle's frame. The illustrations below show the possible arrangements recommended by Blue Ox®. Each permanent baseplate safety cable must have an adequate weight rating for the towing system. The weight rating of the two (2) cables together will not qualify.

Do not mount the permanent baseplate safety cables against wires, hoses or brake lines.

These permanent baseplate safety cables should remain installed as long as the baseplate is installed on the vehicle. Permanent baseplate safety cables are to be used in conjunction with, and NOT a replacement for legally required safety cables attaching the towed vehicle to the towing vehicle.

OPTION #1

Permanent Baseplate Safety Cables to Cross Member or Frame of Towed Vehicle.

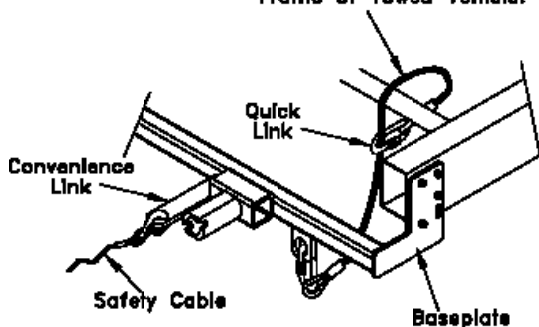

OPTION #2

Permanent Baseplate Safety Cables to Cross Member or Frame of Towed Vehicle.

