



BLUE OX®

Baseplate Installation Instructions

BX2186 2005-09 Ford Mustang Installation Instructions

Please read **BOTH** these Installation Instructions and the General Towing Instructions before attempting to install or operate this equipment.

- 1. Blue Ox® towing products and accessories are intended to be installed by Blue Ox® Dealers who are familiar with our products and have the equipment and knowledge to do "fit work".
 - Attachment Tab Height: 11 1/2"
 - Attachment Tab Width: 27"

- 2. Many Blue Ox® Baseplates are designed to use existing holes and hardware to mount the baseplate to the towed vehicle. Even though bolts are there, do not assume they are adequate for baseplate mounting. Always use hardware supplied in the hardware kit or existing hardware specified in the Baseplate Installation Instructions.

Bolt Torque Specifications

Torque in Foot-Pounds for Metric Bolts

Bolt Size	Grade 8.8	Grade 10.9
6MM	6	8
8MM	16	22
10MM	31	40
12MM	54	70
14MM	89	117

Confirm the towability and pre-towing procedures for your vehicle with the owner's manual or contact the vehicle's manufacturer for specific towing procedures.

Bolt Torque Specifications

Torque in Foot-Pounds for Inch Bolts

Bolt Size	Grade 5	Grade 8
1/4"	10	14
5/16"	19	29
3/8"	33	47
7/16"	54	78
1/2"	78	119
5/8"	154	230



! WARNING

Failure to read and follow these instructions could result in separation of the towed vehicle from the tow bar, causing property damage, loss of towed vehicle, personal injury or death.

BX2186

2005-09 Ford Mustang

Installation Instructions

Parts List

Ref. No.	Qty.	Part #	Description
1	1	61-6296	Weldment, Base Plate, BX2186
2	4	61-5208	3/8-16" Nut Plate with 14" Wire
3	2	106-0368	Pipe, 3/8" Schedule 40, 1/2 Inch
4	4	201-0440	3/8-16 x 1 1/2" Bolt, Grd. 5, ZP
5	2	201-0404	3/8-16 x 1 3/4" Bolt, Grd. 5, ZP
6	6	203-0010	3/8" Lock Washer
7	2	202-0003	3/8-16 Hex Nut, ZP
8	2	201-0979	#12-14 x 1" Self Drilling Screw, ZP
9	2	201-0192	#10-32 x 1/2" Slot, Rd. Hd. Screw
10	2	203-0054	#10 Lock Washer
11	2	202-0047	#10-32 Hex Nut
12	2	101-5822	Adapter, 4 Way Connector
13	2	62-3468	Attachment, Assembly, SF/SB (R)
	2	226-0046	Baseplate Safety Cable, 36" CL III (Not Shown)
	4	229-0359	Quicklink, 3/8, ZP (Not Shown)
	2	290-0437	Receiver, Cap Plug, Black (Not Shown)

Tools Required

Loctite® RED
 10mm Socket
 13mm Socket
 9/16" Socket
 Phillips Screwdriver
 13/32" Carbide Drill Bit
 Vise Grips
 1 1/4" Hole Saw
 Side Cutters
 Tape Measure

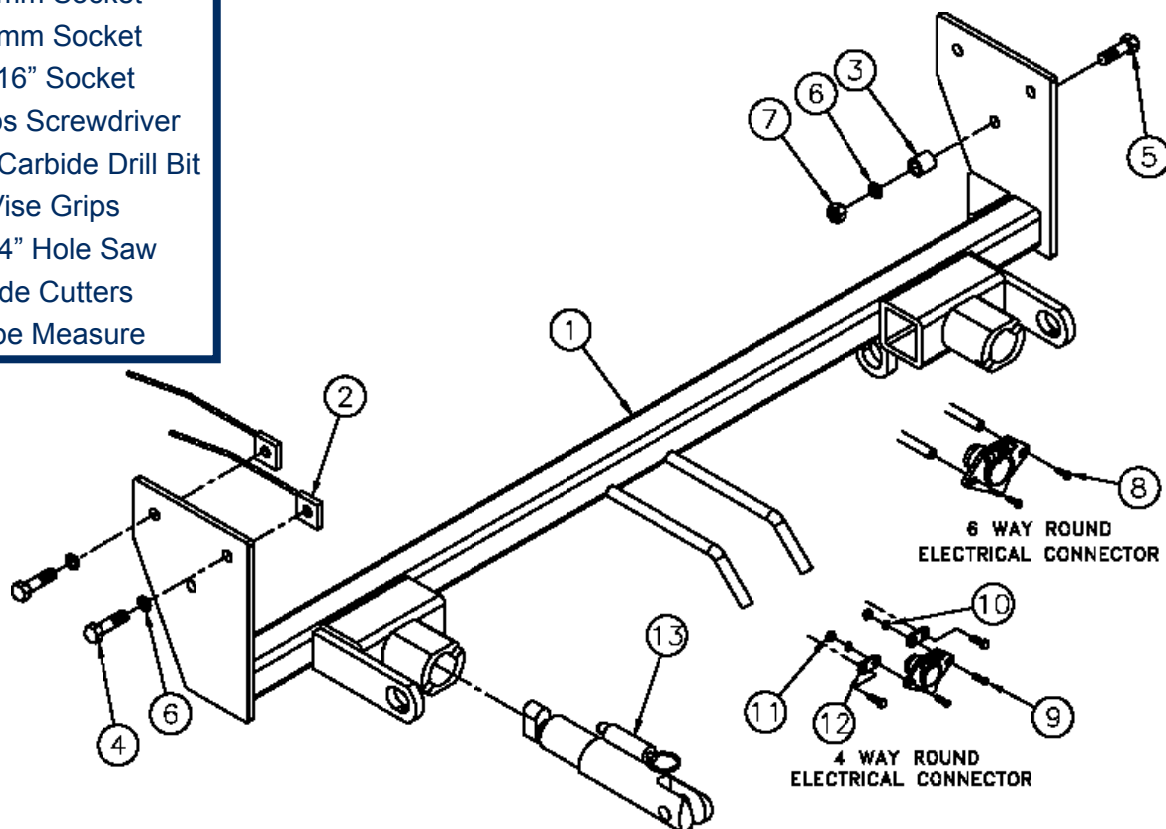

Important:

Use only genuine factory replacement parts on your baseplate. Do **NOT** substitute homemade or non-typical parts. If a bolt is lost or in need of replacement, for your safety and the preservation of your baseplate, be sure to use a replacement bolt of the same grade (In most cases it will be Grade 5, please reference the parts list above). Replacement parts may be ordered through your nearest Blue Ox® Dealer or Distributor.

BX2186

2005-09 Ford Mustang

Installation Instructions

Attachment Tabs:

Due to the design of the removable tabs, the RangeFinderII and Ambassador tow bars can not be used. Adapters, except the BX8833 and BX88151, can not be used with this baseplate.

Installation Notes: The radiator cover, fascia, styrofoam bumper and metal bumper are removed for installation. Drilling is required.

The dimensional variations between otherwise identical vehicles can be considerable.

While the baseplate was designed for easy installation, it may be necessary to tailor the baseplate slightly to compensate for auto manufacturer's tolerances. These minor adjustments may include filing a hole slightly, bending electrical rods, and/ or bending end plates.

The BX8848 4 Diode Wiring Kit is recommended for this vehicle.

Installation Instructions:

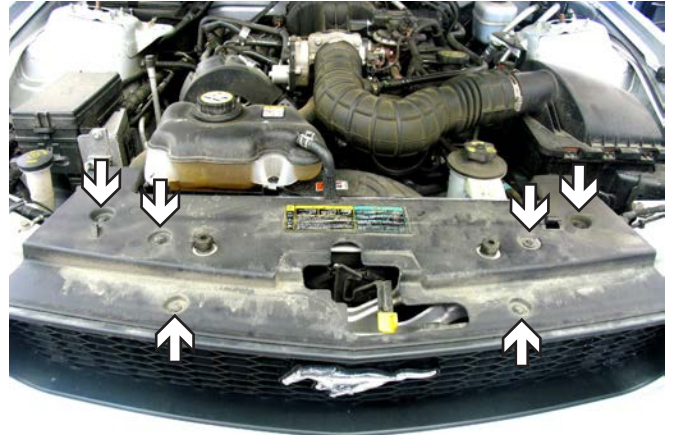

1

1. Remove six pushpins from the radiator cover. Remove radiator cover. Set pushpins and radiator cover aside to be reinstalled later.



2

2. Using the 10mm socket, remove one metric bolt from the top of fascia, next to the headlight assembly. Do this to both sides of the vehicle. Set bolts aside to be reinstalled later.

BX2186
2005-09 Ford Mustang
Installation Instructions



3. Just forward of the front tire, on edge of fascia, remove three Phillips screws. Do this to both sides of the vehicle. Set screws aside to be reinstalled later.



4. Push wheel well cover aside to remove two metric bolts and nuts from the upper corner of fascia using the 10MM socket. Do this to both sides of the vehicle. Set bolts aside to be reinstalled later.



5. Remove seven Phillips pushpins along the bottom of fascia, three each side and one in the center. Pull fascia forward to remove. Set pushpins and fascia aside to be reinstalled later. Passenger's side is shown.

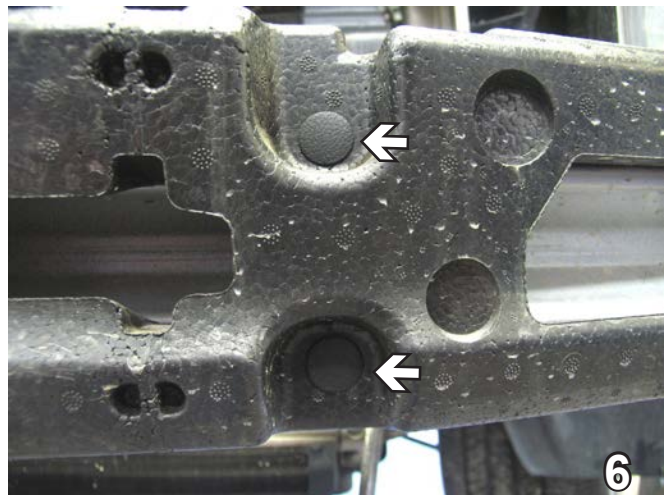

6. Remove two Christmas tree pushpins from front of styrofoam bumper. Do this to both sides of the vehicle. Pull styrofoam bumper forward to remove. Set styrofoam bumper and pushpins aside to be reinstalled later.

BX2186
2005-09 Ford Mustang
Installation Instructions

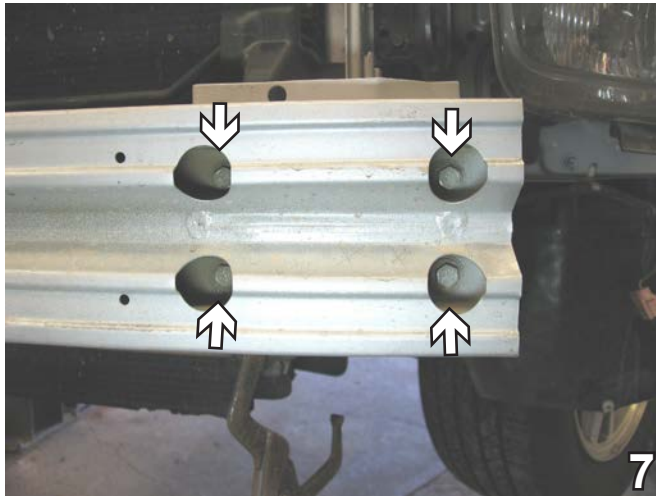

7. Using the 13mm socket, remove four metric bolts from the metal bumper. Do this to both sides of the vehicle. Pull metal bumper forward to remove. Set bolts and metal bumper aside to be reinstalled later.

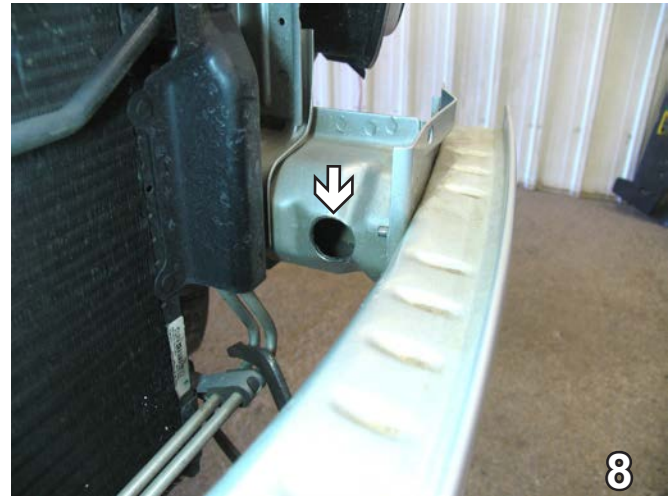

8. Using the 1 1/4" hole saw, drill a hole on the inside edge of frame rail. Do this to both sides of the vehicle. Reinstall metal bumper.

BE SURE TO USE LOCTITE® RED ON ALL BOLTS BEFORE TIGHTENING. TIGHTEN ALL BOLTS ACCORDING TO THE TORQUE CHART ON THE FRONT PAGE OF THESE INSTRUCTIONS OR ON PAGE 3 OF THE BASEPLATE TOWING GENERAL INSTRUCTIONS.



9. Slide baseplate onto the outside of frame rails. Align with upper, existing bolt hole (see grey arrow). The top of the cross tube should be 2 1/4" from the bottom of metal bumper (see white arrow) and the front of baseplate endplate should be resting against the back of the metal bumper bracket. Clamp into place using the vise grips. Do this to both sides of the vehicle.

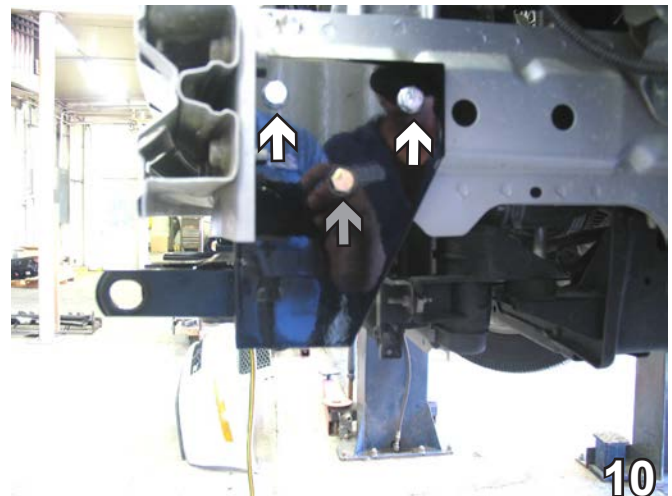

10. Using baseplate as a template, drill 3 holes in frame rail with the 13/32" Carbide drill bit. Insert 3/8-16 nut plates into opening of frame rail and align with upper two holes. Insert 3/8-16 x 1 1/2" bolts and 3/8" lock washers into upper two holes and tighten to 3/8-16" nut plates (see white arrows). Install 3/8-16 x 1 3/4" bolt, 3/8" spacer pipe, 3/8" lock washer and 3/8-16 hex nut to lower hole (see grey arrow). Do this to both sides of the vehicle.

BX2186
2005-09 Ford Mustang
Installation Instructions



11. Hold fascia up to it's original position and, using the side cutters, trim grille style to allow convenience link and attachment tab receiver to come through. Do this to both sides of the vehicle.



12. Attach the permanent baseplate safety cables to the provided convenience link on the baseplate (see grey arrow). The photo above shows the recommended installation of the cables to frame of vehicle (see white arrow). Additional options may interfere with suggested mounting; in this case secure the cables to a solid piece of the frame as described in the instructions included with the permanent baseplate safety cables. Be sure the safety cables do not rub against any hoses or moving parts.

Be sure that **ALL** electrical connections are plugged in properly and functioning **BEFORE** installing the fascia.

13. Reinstall the metal bumper, styrofoam bumper, fascia, radiator cover, pushpins, bolts and screws.

Install the tow bar and safety cables according to the instructions provided in their packages. When demonstrating this to the customer, be sure to include all the contents and packages.

Do **NOT** substitute other devices if the tow bar pins and clips are misplaced.

DEALER or INSTALLER:
Be certain the user receives the instruction sheets for their products.

BX2186
2005-09 Ford Mustang
Installation Instructions



Shown without removable tabs installed.

If the baseplate is in an accident, it must be replaced. DO NOT use it again! An accident can cause unseen damage and using it again could result in more damage or serious injury. DO NOT use the baseplate if it is damaged or missing parts.



Shown with removable tabs installed.

General Information

1. It is the owner's responsibility to inspect all towing equipment for cracked welds, missing or worn parts and loose bolts before each towing trip. Be sure to use Loctite® Red on all bolts and tighten to the recommended specifications.
2. It is the owner's responsibility to hook up all towing equipment per manufacturer's instructions/ recommendations.
3. Remove the attachment tabs when not in use (if applicable).

Notice To Baseplate Installer

1. It is YOUR responsibility to watch for:

- Oil cooler and air conditioner lines
- Electrical wires and hoses
- Missing parts or attaching points on the frame

** If the baseplate is improperly installed and is against a wire or hose, it could cause fluid leaks or electrical shorts some time after the actual baseplate installation.

Permanent Baseplate Safety Cable Installation

Permanent baseplate safety cables are strongly recommended when towing a vehicle with a tow bar. The principle function of the permanent baseplate safety cables is to prevent the towed vehicle from breaking loose in the event the connection between the frame of the towed vehicle and the baseplate fails or becomes disconnected. The cables must be connected from the baseplate to the frame rail or cross member of the vehicle's frame. The illustrations below show the possible arrangements recommended by Blue Ox®. Each permanent baseplate safety cable must have an adequate weight rating for the towing system. The weight rating of the two (2) cables together will not qualify.

Do not mount the permanent baseplate safety cables against wires, hoses or brake lines.

These permanent baseplate safety cables should remain installed as long as the baseplate is installed on the vehicle. Permanent baseplate safety cables are to be used in conjunction with, and NOT a replacement for legally required safety cables attaching the towed vehicle to the towing vehicle.

OPTION #1

Permanent Baseplate Safety Cables to Cross Member or Frame of Towed Vehicle.

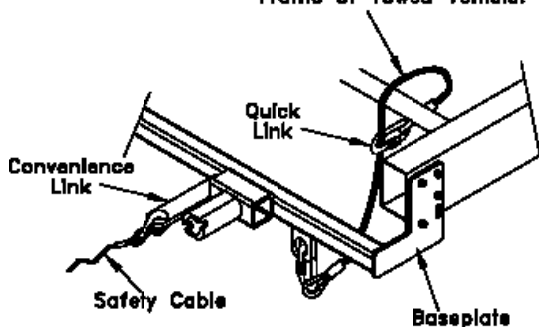

OPTION #2

Permanent Baseplate Safety Cables to Cross Member or Frame of Towed Vehicle.

