



BX1725

2016-18 Chevy Spark Installation Instructions

Attachment Tab Height: 15"

Attachment Tab Width: 24"

Please read BOTH these Installation Instructions and the General Information sheet prior to installing or operating this equipment.

1. Blue Ox® towing products and accessories are intended to be installed by Blue Ox® Dealers who are familiar with our products and have the equipment and knowledge necessary to do "it work".
2. Many Blue Ox® baseplates are designed to use existing holes and hardware to mount the baseplate to the towed vehicle. Even though bolts are there, do not assume they are adequate for baseplate mounting. Always use the hardware supplied in the hardware kit and existing hardware as specified in the installation instructions.

Bolt Torque Specifications		
Torque in Foot-Pounds for Inch Bolts		
Bolt Size	Grade 5	Grade 8
1/4"	10	14
5/16"	19	29
3/8"	33	47
7/16"	54	78
1/2"	78	119
5/8"	154	230
3/4"	257	380



Bolt Torque Specifications		
Torque in Foot-Pounds for Metric Bolts		
Bolt Size	Grade 8.8	Grade 10.9
6MM	6	8
8MM	16	22
10MM	31	40
12MM	54	70
14MM	89	117
16MM	161	230
18MM	222	318

Reference your vehicle owner's manual for manufacturer's towing specifications.

! WARNING

Failure to read and follow these instructions could result in separation of the towed vehicle from the tow bar, causing property damage, loss of towed vehicle, personal injury or death.

BX1725
2016-18 Chevy Spark
Installation Instructions

Instruction Notes: The fascia and bumper are removed and reinstalled for the baseplate installation. Some drilling and trimming is required.

Place all components that are removed on a flat, sturdy surface. All items will be reinstalled unless otherwise noted after the baseplate is installed.

The dimensional variations between otherwise identical vehicles can be considerable. While the baseplate was designed for easy installation, it may be necessary to tailor the baseplate slightly to compensate for vehicle manufacturer's tolerances.

The BX8869 Tail Light Wiring Kit is recommended for this vehicle.



Drill a hole according to the tail
light wiring kit instructions.

NOTICE

- Handling of some cosmetic parts when installing this product may require the use of protective covers, rags, specialty tools, etc. to prevent damage.
- When using power drills be aware of the dangers of torque and drill bit length.
- When using a reciprocating saw be aware of objects behind the cutting surface.
- Use a good quality paint to spray cut edges of frame to prevent rusting.
- Be sure that **ALL** electrical connections are plugged in and accessories are functioning properly before reinstalling the fascia.
- The baseplate is computer tested to your vehicle's GVWR, exceeding this weight will void the manufacturer's warranty.
- Be sure to use a sufficient amount of Loctite® Red on all bolt threads before tightening. Tighten all bolts according to the torque chart provided.
- Dealer or installer be certain the user receives these instruction sheets.
- If the baseplate is in an accident, it must be replaced. **DO NOT** use it again! An accident can cause unseen damage and using it again could result in more damage or serious injury. **DO NOT** use the baseplate if it is damaged or missing parts.

BX1725

2016-18 Chevy Spark Installation Instructions

Tools Required

Flat Screwdriver
 Utility Knife
 Torque Wrench
 Drill
 Loctite® RED
 3/8" Drill Bit
 7MM Socket
 10MM Socket
 13MM Socket
 5/16" Nut Driver
 7/16" Socket
 7/16" Wrench
 9/16" Socket
 9/16" Wrench

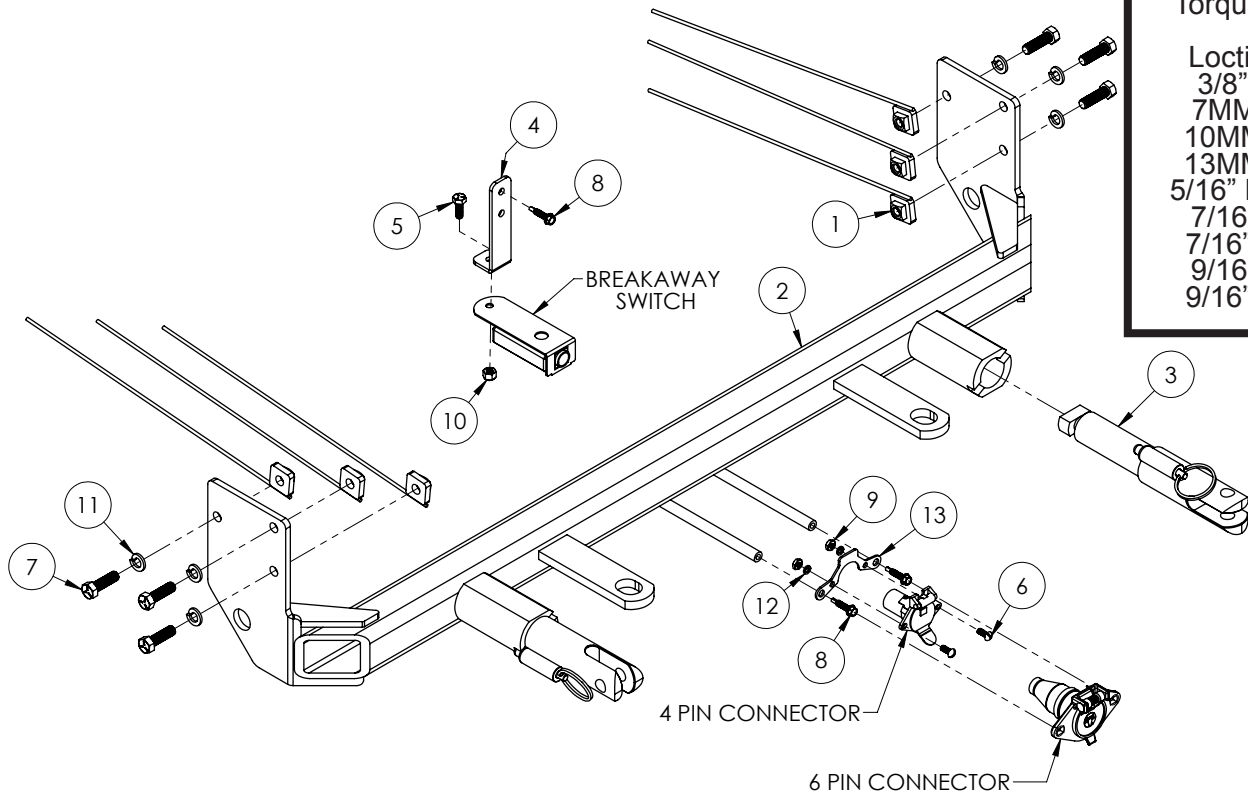

Item No.	Part No.	Description	Qty.
1.....	61-5208	3/8" Nut Plate w/ 14" Wire	6
2.....	61-7669	BX1725 Baseplate.....	1
3.....	62-3469	Attachment Tab Assembly with Hole	2
4.....	102-7186	Breakaway Bracket	1
5.....	201-0050	1/4"-20 x 3/4" Hex Head Bolt, Grade 5, ZP	1
6.....	201-0192	#10-32 1/2" Round Slotted Head Screw.....	2
7.....	201-0368	3/8"-16 x 1-1/4" Hex Head Bolt, Grade 5, ZP	6
8.....	201-0979	#12-14 x 1" Self Drilling Screw, ZP.....	3
9.....	202-0047	#10-32 Hex Nut	2
10.....	202-0102	1/4"-20 Hex Nylon Nut, ZP	1
11.....	203-0010	3/8" Lock Washer, ZP	6
12.....	203-0054	#10 Lock Washer, ZP	2
13.....	299-0685	Electrical Bracket.....	1
14.....	226-0046(not shown)	Class III Safety Cables	2
15.....	229-0359(not shown)	3/8" Quicklink, ZP	2
16.....	290-0437(not shown)	Black Cap Plug Receiver.....	2

Important:

Use only genuine factory replacement parts on your baseplate. Do **NOT** substitute homemade or non-typical parts. If a bolt is lost or in need of replacement, for your safety and the preservation of your baseplate, be sure to use a replacement bolt of the same grade (In most cases it will be Grade 5, please reference the parts list above). Replacement parts may be ordered through your nearest Blue Ox® Dealer or Distributor. Failing to follow and/or altering these installation instructions in either installation or required equipment will void the manufacturer's warranty. Towing behind a non-motorized vehicle will void the warranty.

BX1725
2016-18 Chevy Spark
Installation Instructions

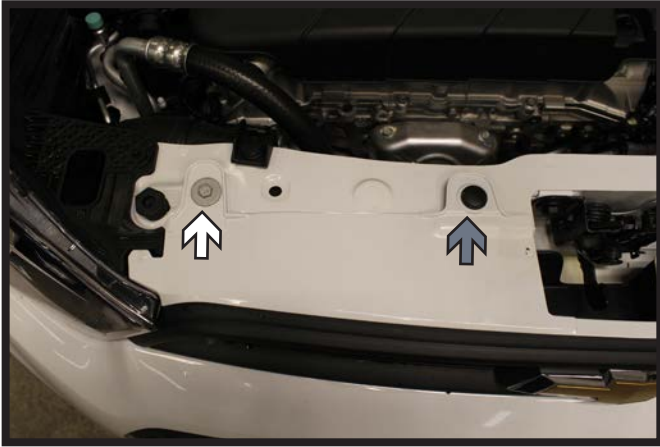

1. Using a 10MM socket, remove the screw from the top edge of the fascia (white). Then remove the push pin inwards toward the hood latch (gray). Do this on both sides of the vehicle.



2. Remove the two (2) push pins from along the edge of the wheel well. Do this on both sides of the vehicle.

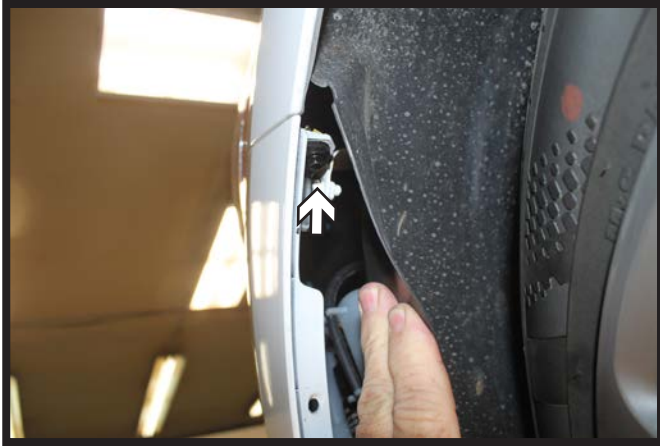

3. Behind the wheel well liner, using a 7MM socket, remove the screw from the fascia/fender joint. Do this on both sides of the vehicle.

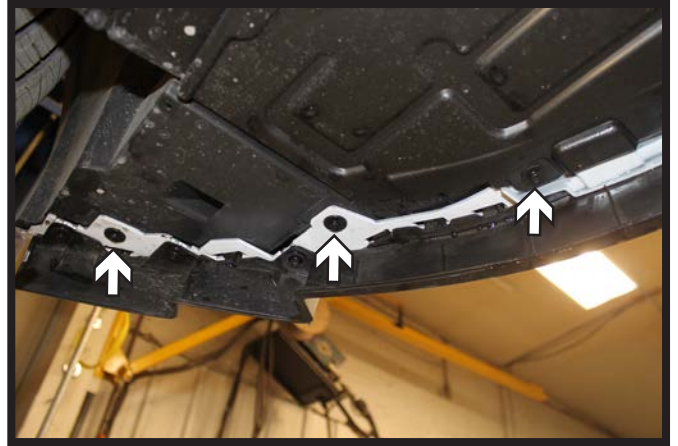

4. Using a 7MM socket, remove the eight (4) screws from the underside of the fascia. There are three (3) on each side and two (2) in the center.

BX1725
2016-18 Chevy Spark
Installation Instructions



5. Pull the corners of the fascia away from the vehicle disconnecting any electrical connections and set the fascia aside.

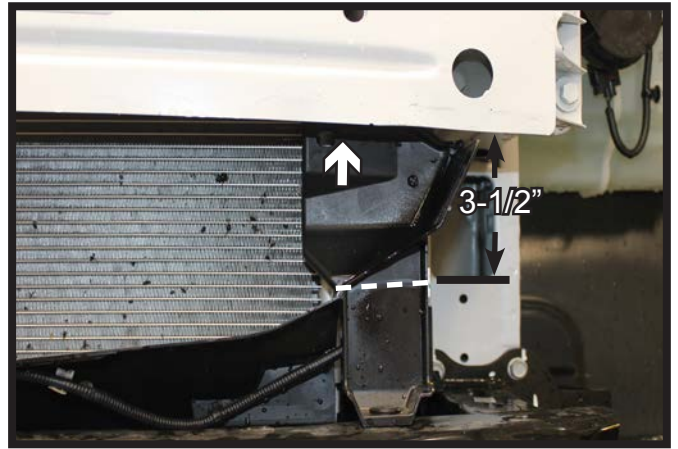

6. Measure down approximately 3-1/2" and cut thru the plastic shielding. Remove the upper push pin and discard the upper portion of the shielding. Do this on both sides of the vehicle.

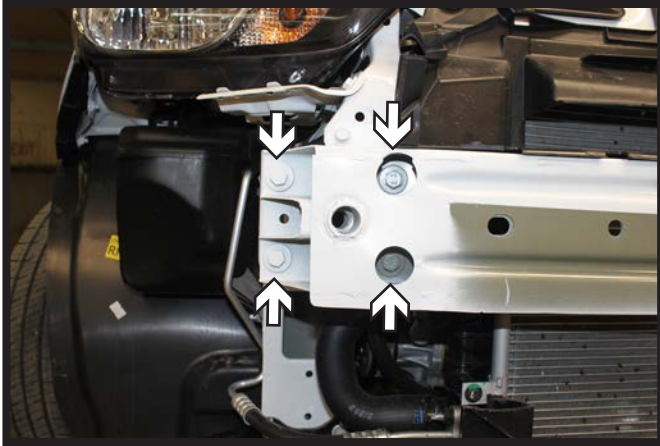

7. Remove the four (4) push pins from the top of the bumper.

Using a 13MM socket, remove the eight (14) screws from the bumper. There are four (4) on each side. Set the bumper aside.



8. Using a 3/8" drill bit, ream out the existing rear passenger side hole.

BX1725
2016-18 Chevy Spark
Installation Instructions

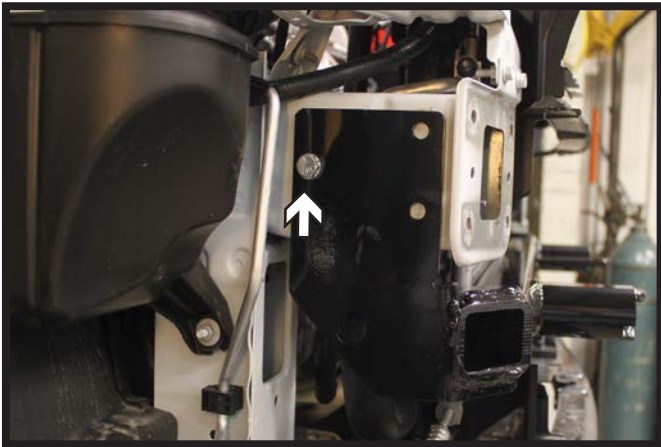

9. Align the baseplate to the frame, installing the 3/8" hardware into the rear holes on both sides. Level the baseplate and fully tighten the hardware.

** Use Loctite® Red on all bolt threads and tighten all bolts to the appropriate torque.

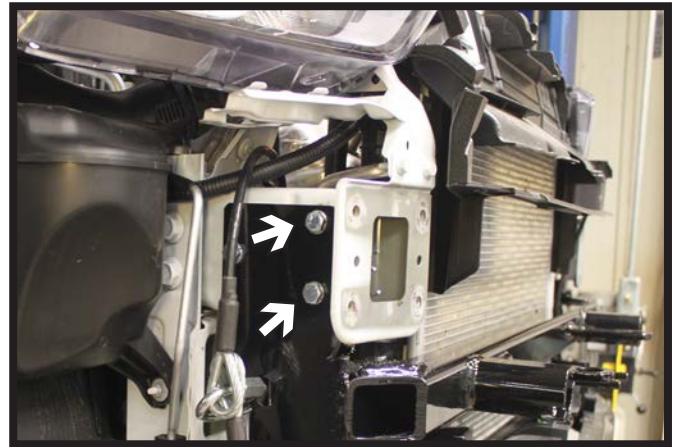

10. Using a 3/8" drill bit, drill the remaining holes thru the frame. Install the 3/8" hardware and fully tighten. Do this on both sides of the vehicle.

** Use Loctite® Red on all bolt threads and tighten all bolts to the appropriate torque.



11. Attach the permanent baseplate safety cables to the provided convenience link on the baseplate. The photo above shows the recommended installation of the cables to frame of vehicle. Additional options may interfere with suggested mounting; in this case, secure the cables to a solid piece of the frame as described in the General Information sheet. Be sure the safety cables do not rub against any hoses or moving parts. Do this on **BOTH** sides of the vehicle.



12. **Optional Breakaway:** Using a self tapping screw, attach the bracket to the lip of the bumper in the desired location. Attache the breakaway to the bracket with the supplied 1/4" hardware.

BX1725
2016-18 Chevy Spark
Installation Instructions



13. Hold the fascia as close to its original position, mark and trim the fascia around the convenience links and attachment tabs. Reinstall the bumper and fascia.



General Information

1. It is the owner's responsibility to inspect all towing equipment for cracked welds, missing or worn parts and loose bolts before each towing trip. Be sure to use Loctite® Red on all bolts and tighten to the recommended specifications.
2. It is the owner's responsibility to hook up all towing equipment per manufacturer's instructions/ recommendations.
3. Remove the attachment tabs when not in use (if applicable).

Notice To Baseplate Installer

1. It is YOUR responsibility to watch for:

- Oil cooler and air conditioner lines
- Electrical wires and hoses
- Missing parts or attaching points on the frame

** If the baseplate is improperly installed and is against a wire or hose, it could cause fluid leaks or electrical shorts some time after the actual baseplate installation.

Permanent Baseplate Safety Cable Installation

Permanent baseplate safety cables are strongly recommended when towing a vehicle with a tow bar. The principle function of the permanent baseplate safety cables is to prevent the towed vehicle from breaking loose in the event the connection between the frame of the towed vehicle and the baseplate fails or becomes disconnected. The cables must be connected from the baseplate to the frame rail or cross member of the vehicle's frame. The illustrations below show the possible arrangements recommended by Blue Ox®. Each permanent baseplate safety cable must have an adequate weight rating for the towing system. The weight rating of the two (2) cables together will not qualify.

Do not mount the permanent baseplate safety cables against wires, hoses or brake lines.

These permanent baseplate safety cables should remain installed as long as the baseplate is installed on the vehicle. Permanent baseplate safety cables are to be used in conjunction with, and NOT a replacement for legally required safety cables attaching the towed vehicle to the towing vehicle.

OPTION #1

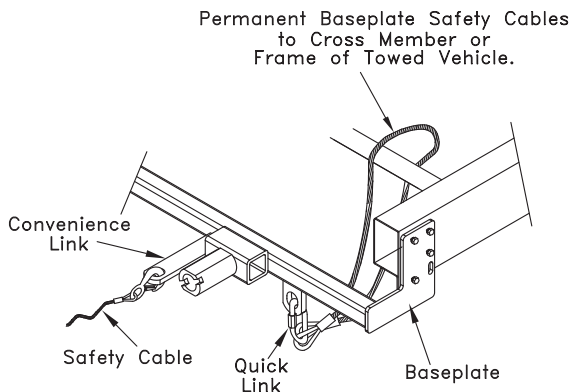

OPTION #2

