



BX1719

2003-16 Chevy Express 1500/2500/3500
2003-16 GMC Savanna 1500/2500/3500
Cargo & Passenger Vans
Installation Instructions

Attachment Tab Height: 13-1/2"

Attachment Tab Width: 24"

Please read BOTH these Installation Instructions and the General Information sheet prior to installing or operating this equipment.

1. Blue Ox® towing products and accessories are intended to be installed by Blue Ox® Dealers who are familiar with our products and have the equipment and knowledge necessary to do "it work".
2. Many Blue Ox® baseplates are designed to use existing holes and hardware to mount the baseplate to the towed vehicle. Even though bolts are there, do not assume they are adequate for baseplate mounting. Always use the hardware supplied in the hardware kit and existing hardware as specified in the installation instructions.

Bolt Torque Specifications
Torque in Foot-Pounds for Inch Bolts

Bolt Size	Grade 5	Grade 8
1/4"	10	14
5/16"	19	29
3/8"	33	47
7/16"	54	78
1/2"	78	119
5/8"	154	230
3/4"	257	380



Bolt Torque Specifications
Torque in Foot-Pounds for Metric Bolts

Bolt Size	Grade 8.8	Grade 10.9
6MM	6	8
8MM	16	22
10MM	31	40
12MM	54	70
14MM	89	117
16MM	161	230
18MM	222	318

Reference your vehicle owner's manual for manufacturer's towing specifications.

! WARNING

Failure to read and follow these instructions could result in separation of the towed vehicle from the tow bar, causing property damage, loss of towed vehicle, personal injury or death.

BX1719

2003-16 Chevy Express 1500/2500/3500 & GMC Savanna 1500/2500/3500 Cargo & Passenger Vans Installation Instructions

Instruction Notes: The headlights, grille and bumper are removed and reinstalled for the baseplate installation. Some drilling and trimming is required.

Place all components that are removed on a flat, sturdy surface. All items will be reinstalled unless otherwise noted after the baseplate is installed.

The dimensional variations between otherwise identical vehicles can be considerable. While the baseplate was designed for easy installation, it may be necessary to tailor the baseplate slightly to compensate for vehicle manufacturer's tolerances.

The BX8869 Tail Light Wiring Kit is recommended for this vehicle.



Drill a hole according to the tail light wiring kit instructions.

NOTICE

- Handling of some cosmetic parts when installing this product may require the use of protective covers, rags, specialty tools, etc. to prevent damage.
- When using power drills be aware of the dangers of torque and drill bit length.
- When using a reciprocating saw be aware of objects behind the cutting surface.
- Use a good quality paint to spray cut edges of frame to prevent rusting.
- Be sure that **ALL** electrical connections are plugged in and accessories are functioning properly before reinstalling the fascia.
- The baseplate is computer tested to your vehicle's GVWR, exceeding this weight will void the manufacturer's warranty.
- Be sure to use a sufficient amount of Loctite® Red on all bolt threads before tightening. Tighten all bolts according to the torque chart provided.
- Dealer or installer be certain the user receives these instruction sheets.
- If the baseplate is in an accident, it must be replaced. **DO NOT** use it again! An accident can cause unseen damage and using it again could result in more damage or serious injury. **DO NOT** use the baseplate if it is damaged or missing parts.

BX1719

2003-16 Chevy Express 1500/2500/3500 & GMC Savanna 1500/2500/3500 Cargo & Passenger Vans Installation Instructions

Tools Required

Large Vise Grip
Flat Screwdriver
Torque Wrench
Drill
Tape Measure
Loctite® RED
17/32" Drill Bit
10MM Socket
15MM Socket
21MM Socket
3/4" Socket

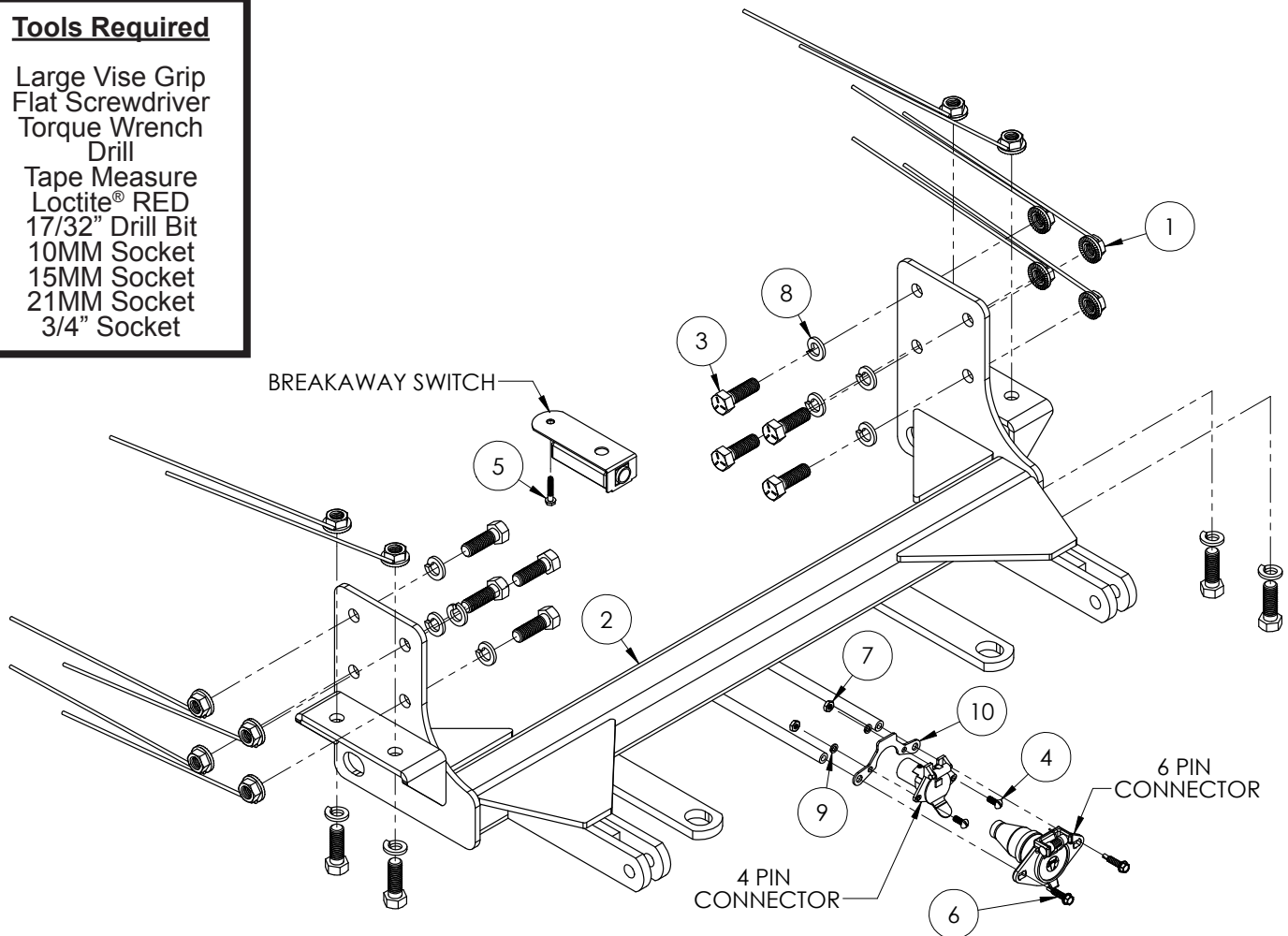

Item No.	Part No.	Description	Qty.
1.....	61-4029.....	1/2"-13 Whiz Nut w/ 10" Wire	12
2.....	61-7360.....	BX1719 Baseplate.....	1
3.....	201-0051.....	1/2"-13 x 1-1/2" Hex Head Bolt, Grade 5, ZP	12
4.....	201-0192.....	#10-32 1/2" Round Slotted Head Screw.....	2
5.....	201-0979.....	#12-14 x 1" Self Drilling Screw, ZP.....	2
6.....	201-0654.....	#10-16 x 1" Self Drilling Screw, ZP.....	1
7.....	202-0047.....	#10-32 Hex Nut	2
8.....	203-0012.....	1/2" Lock Washer, ZP	12
9.....	203-0054.....	#10 Lock Washer, ZP	2
10.....	299-0685.....	4-Way Bracket.....	1
11.....	226-0049(not shown).....	Class IV Safety Cables.....	2
12.....	229-0512(not shown).....	1/2" Quicklink, ZP	2

Important:

Use only genuine factory replacement parts on your baseplate. Do **NOT** substitute homemade or non-typical parts. If a bolt is lost or in need of replacement, for your safety and the preservation of your baseplate, be sure to use a replacement bolt of the same grade (In most cases it will be Grade 5, please reference the parts list above). Replacement parts may be ordered through your nearest Blue Ox® Dealer or Distributor. Failing to follow and/or altering these installation instructions in either installation or required equipment will void the manufacturer's warranty. Towing behind a non-motorized vehicle will void the warranty.

BX1719

2003-16 Chevy Express 1500/2500/3500 & GMC Savanna 1500/2500/3500 Cargo & Passenger Vans Installation Instructions

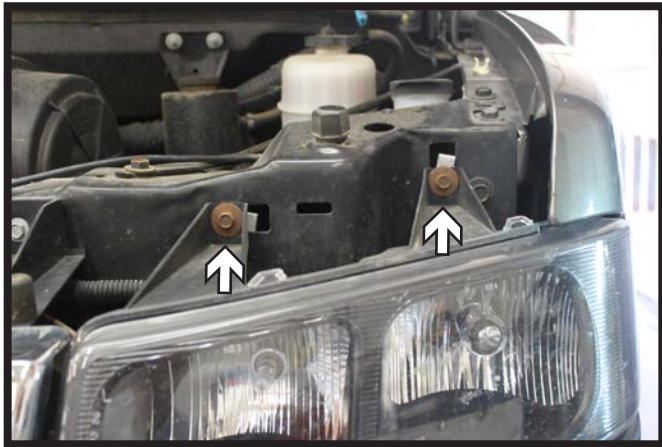

1. Using a 10MM socket, remove the two (2) screws from the headlight. Disconnect all electrical connections and set aside. Do this on both sides of the vehicle.

Note: The headlights do not need to be removed on vehicles equipped with sealed halogen lights.



2. Using a flat screwdriver, pry behind the grille to release the clip and release the park light from frame. Disconnect all electrical connections and set aside. Do this on both sides of the vehicle.



3. Using a 10MM socket, remove the four (4) screws from the grille. There are two (2) on each side.

Behind the grille towards the bottom, release the clips on both sides of the vehicle. Set the grille aside.



4. Position the baseplate onto the frame, lining up front hole on the underside of the frame and the back hole of the baseplate. Square and clamp the baseplate securely to the frame.

BX1719

2003-16 Chevy Express 1500/2500/3500 & GMC Savanna 1500/2500/3500 Cargo & Passenger Vans Installation Instructions



5. Using a 17/32" drill bit, ream out the bottom back hole. Install a 1/2"-13 x 1-1/2" bolt with lock washer into the hole and a 1/2" whiz nut on the inside of the frame. Do this on both sides of the vehicle. Fully tighten all hardware.

Note: The frame hole may need to be slightly reamed to allow whiz nut access.

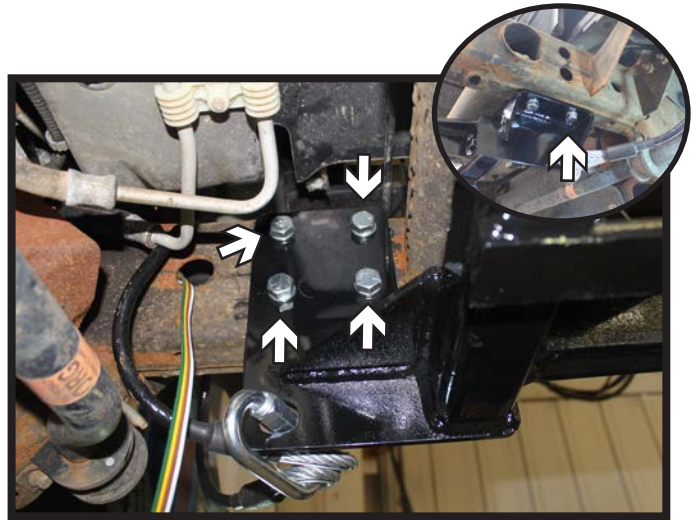

6. Continue drilling the remaining holes in the baseplate thru the frame. Install 1/2"-13 x 1-1/2" bolts with lock washers into the holes and a 1/2" whiz nuts on the inside of the frame. Do this on both sides of the vehicle. Fully tighten all hardware.



7. Attach the permanent baseplate safety cables to the provided convenience link on the baseplate. The photo above shows the recommended installation of the cables to frame of vehicle. Additional options may interfere with suggested mounting; in this case, secure the cables to a solid piece of the frame as described in the instructions included with the permanent baseplate safety cables. Be sure the safety cables do not rub against any hoses or moving parts. Do this on **BOTH** sides of the vehicle.

BX1719

2003-16 Chevy Express 1500/2500/3500 & GMC Savanna 1500/2500/3500 Cargo & Passenger Vans Installation Instructions

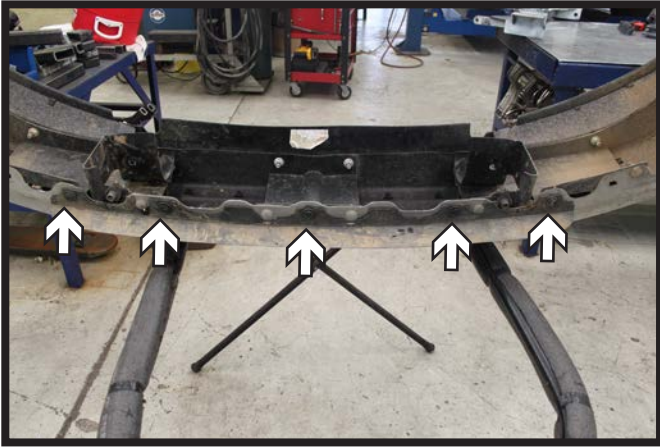

8. Remove the five (5) push pins from the lower valance on the bumper. The valance will not be reinstalled for baseplate clearance.



9. Reinstall the bumper, grille, park lights and headlights.



General Information

1. It is the owner's responsibility to inspect all towing equipment for cracked welds, missing or worn parts and loose bolts before each towing trip. Be sure to use Loctite® Red on all bolts and tighten to the recommended specifications.
2. It is the owner's responsibility to hook up all towing equipment per manufacturer's instructions/ recommendations.
3. Remove the attachment tabs when not in use (if applicable).

Notice To Baseplate Installer

1. It is YOUR responsibility to watch for:

- Oil cooler and air conditioner lines
- Electrical wires and hoses
- Missing parts or attaching points on the frame

** If the baseplate is improperly installed and is against a wire or hose, it could cause fluid leaks or electrical shorts some time after the actual baseplate installation.

Permanent Baseplate Safety Cable Installation

Permanent baseplate safety cables are strongly recommended when towing a vehicle with a tow bar. The principle function of the permanent baseplate safety cables is to prevent the towed vehicle from breaking loose in the event the connection between the frame of the towed vehicle and the baseplate fails or becomes disconnected. The cables must be connected from the baseplate to the frame rail or cross member of the vehicle's frame. The illustrations below show the possible arrangements recommended by Blue Ox®. Each permanent baseplate safety cable must have an adequate weight rating for the towing system. The weight rating of the two (2) cables together will not qualify.

Do not mount the permanent baseplate safety cables against wires, hoses or brake lines.

These permanent baseplate safety cables should remain installed as long as the baseplate is installed on the vehicle. Permanent baseplate safety cables are to be used in conjunction with, and NOT a replacement for legally required safety cables attaching the towed vehicle to the towing vehicle.

OPTION #1

Permanent Baseplate Safety Cables to Cross Member or Frame of Towed Vehicle.

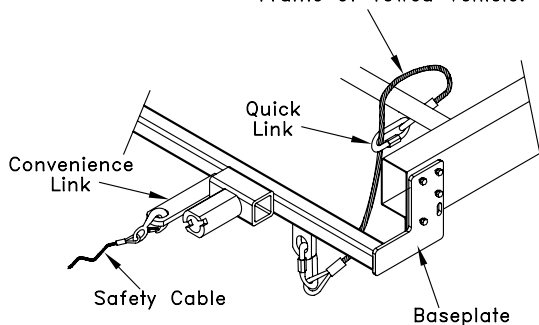

OPTION #2

Permanent Baseplate Safety Cables to Cross Member or Frame of Towed Vehicle.

