

## BX1660



2003-06 Chevy/GMC 1500 Pickup

1999-2007 Chevy/GMC 2500 Pickup

1999-2007 Chevy/GMC 3500 Pickup

2001-06 Chevy Suburban 2500

2000-07 GMC Yukon 2500

The tow hooks are removed for baseplate installation. Some models may require the holes in the frame to be reamed slightly. No trimming is required. The BX8869 is available for the vehicle. Attachment Tabs are 32 1/4 inches center to center and a height of 16 1/2 inches.

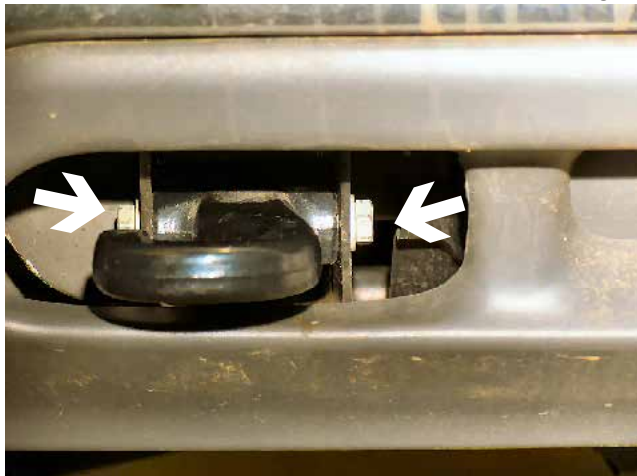

1. Using the 18MM socket, remove the three metric bolts from tow hook, both sides, pull tow hook forward and set aside. **Tow hooks will not be reinstalled.**



2. Using the 21/32" drill bit, ream out the back existing hole on the bottom of frame rail. Slide the driver's side and passenger's side baseplates into the frame rail to align with the two existing holes on the side and two in the bottom of frame rail. Be sure that the proper baseplate is in the correct side (**see last page for correct hole placement for the bottom of frame on driver's side and passenger's side**). Insert the two 1/2-13 x 1 1/4" hex bolts and lock washers into the existing holes in the side of frame rail and tighten with the 3/4" socket, both sides. Align the convenience link to it corresponding side with the existing holes on the bottom of frame rails. Insert the 1/2-13 x 2" hex bolt and 1/2" lock washer into the front hole and tighten with the 3/4" socket, both sides. Insert 5/8-11 x 2" hex bolt and 5/8" lock washers into the back existing hole on the bottom of frame rail and tighten with the 15/16" socket, both sides. **Be sure and use loctite red on all bolts before tightening. Tighten all bolts according to Torque Chart in the General Instruction sheet.**



Strong As An Ox™



*Location for the  
Bx8869 on driver's side  
tail light assembly.*

3. *Some models may require the holes in frame to be reamed slightly to acquire proper fit.*
4. *The dimensional variations between otherwise identical cars can be considerable. While the baseplate was designed for easy installation, it may be necessary to tailor the baseplate slightly to compensate for auto manufactures' tolerances. These minor adjustments may include filing a holes slightly, bending electrical rods, adding shims and/ or bending endplates.*
5. *Install the tow bar and safety cables according to the instructions included in their packages.*
6. *Do **not** substitute other devices if the tow bar pin and clip are lost.*
7. **DEALER OR INSTALLER: BE CERTAIN THE USER RECEIVES THE INSTRUCTION SHEET.**

**IMPORTANT:** Use only genuine factory replacement parts on your Base Plate. Do not substitute homemade or nontypical parts. If a bolt is lost or in need of replacement, for your safety and the preservation of your Base Plate, be sure to use a replacement bolt of the same grade (Usually Grade 5, refer to parts list). Repair parts may be ordered through your nearest **Blue Ox** dealer or distributor.



## Tools Required

18MM Socket  
Loctite Red

3/4" Socket  
1/2" Reaming Tool

15/16" Socket

## Parts List

Ref. No.	Qty.	Part No.	Description
1	1	61-6095	Weldment, Base Plate, DS , BX1660
2	1	61-6096	Weldment, Base Plate, PS , BX1660
3	1	101-6058	Convenience Link, Class IV, DS
4	1	101-6059	Convenience Link, Class IV, PS
5	4	201-0011	1/2-13 x 1 1/4 Hex Bolt, Grd. 5, ZP
6	2	201-0283	1/2-13 x 2 Hex Bolt, Grd. 5, ZP
7	2	201-0351	5/8-11 x 2 Hex Bolt, Grd. 5, ZP
8	6	203-0012	1/2" Lock Washer, ZP
9	2	203-0013	5/8" Lock Washer, ZP
10	2	201-0071	1/4-20 x 1 Hex Bolt, Grd. 5, ZP
11	2	203-0001	1/4" Flat Washer, ZP
12	2	203-0008	1/4" Lock Washer, ZP
13	2	202-0001	1/4-20 Hex Nut, ZP
14	2	62-3468	Attachment, Assembly, SF/ SB (R)
	2	226-0049	Baseplate Safety Cable, 36" CL IV (Not Shown)
	4	229-0512	Quicklink, 1/2, ZP (Not Shown)
	2	290-0437	Cap Plug, Black (Not Shown)

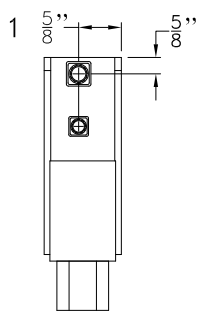

PASSENGER'S  
SIDE

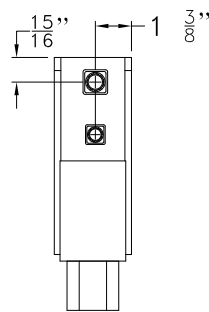

DRIVER'S  
SIDE

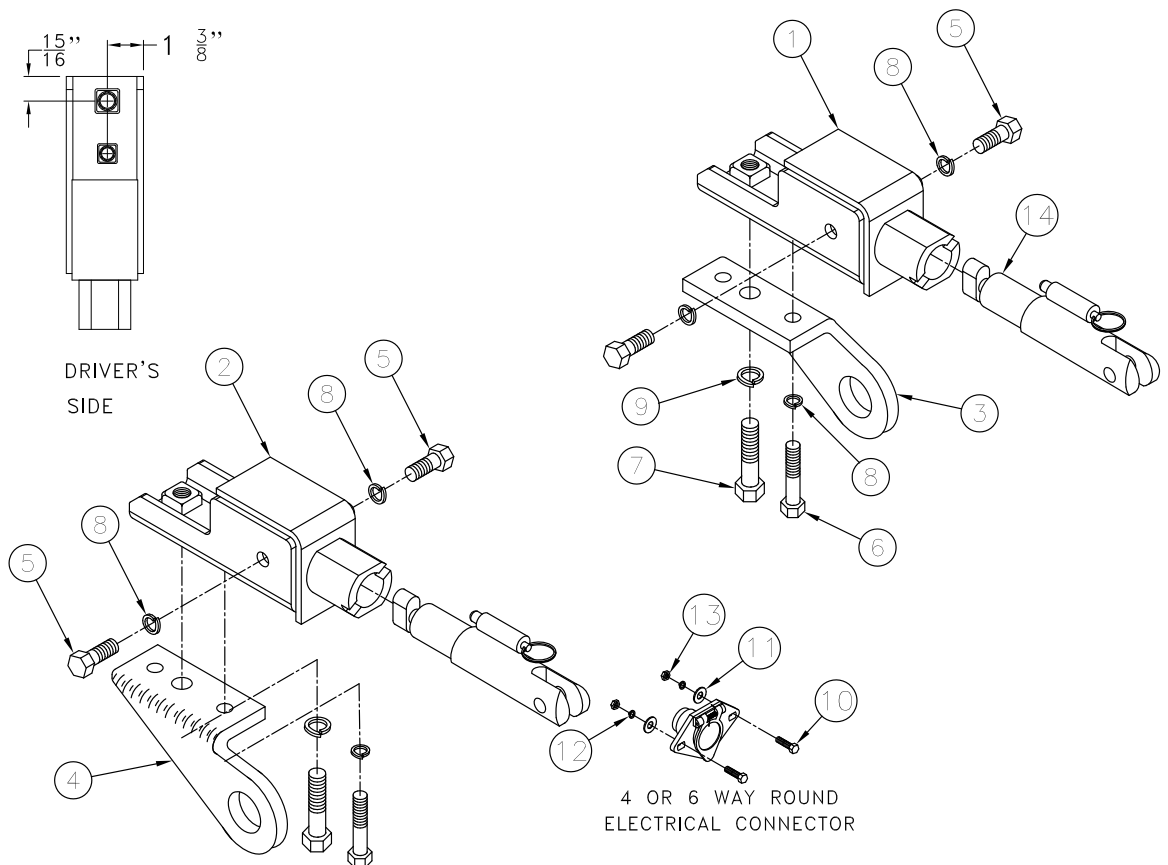

# General Information

1. It is the owner's responsibility to inspect all towing equipment for cracked welds, missing or worn parts and loose bolts before each towing trip. Be sure to use Loctite® Red on all bolts and tighten to the recommended specifications.
2. It is the owner's responsibility to hook up all towing equipment per manufacturer's instructions/ recommendations.
3. Remove the attachment tabs when not in use (if applicable).

## Notice To Baseplate Installer

1. It is YOUR responsibility to watch for:

- Oil cooler and air conditioner lines
- Electrical wires and hoses
- Missing parts or attaching points on the frame

\*\* If the baseplate is improperly installed and is against a wire or hose, it could cause fluid leaks or electrical shorts some time after the actual baseplate installation.

## Permanent Baseplate Safety Cable Installation

Permanent baseplate safety cables are strongly recommended when towing a vehicle with a tow bar. The principle function of the permanent baseplate safety cables is to prevent the towed vehicle from breaking loose in the event the connection between the frame of the towed vehicle and the baseplate fails or becomes disconnected. The cables must be connected from the baseplate to the frame rail or cross member of the vehicle's frame. The illustrations below show the possible arrangements recommended by Blue Ox®. Each permanent baseplate safety cable must have an adequate weight rating for the towing system. The weight rating of the two (2) cables together will not qualify.

***Do not mount the permanent baseplate safety cables against wires, hoses or brake lines.***

These permanent baseplate safety cables should remain installed as long as the baseplate is installed on the vehicle. Permanent baseplate safety cables are to be used in conjunction with, and NOT a replacement for legally required safety cables attaching the towed vehicle to the towing vehicle.

### OPTION #1

Permanent Baseplate Safety Cables to Cross Member or Frame of Towed Vehicle.

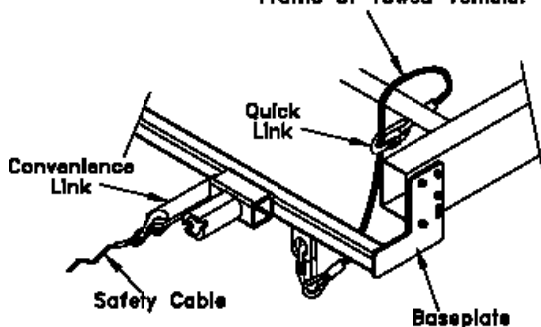

### OPTION #2

Permanent Baseplate Safety Cables to Cross Member or Frame of Towed Vehicle.

