



BX1648

1999-03 Chevrolet Malibu
 2003-05 Chevrolet Malibu Classic
 1999-02 Pontiac Grand Am
 1999-03 Oldsmobile Alero
Installation Instructions

Attachment Tab Height: 13.5"

Attachment Tab Width: 24"

Please read **BOTH** these Installation Instructions and the General Towing Instructions before attempting to install or operate this equipment.

1. Blue Ox® towing products and accessories are intended to be installed by Blue Ox® Dealers who are familiar with our products and have the equipment and knowledge to do "fit work".
2. Many Blue Ox® Baseplates are designed to use existing holes and hardware to mount the baseplate to the towed vehicle. Even though bolts are there, do not assume they are adequate for baseplate mounting. Always use hardware supplied in the hardware kit or existing hardware specified in the Baseplate Towing Installation Instructions.

Bolt Torque Specifications
 Torque in Foot-Pounds per Metric Bolts

Bolt Size	Grade 8.8	Grade 10.9
6MM	6	8
8MM	16	22
10MM	31	40
12MM	54	70
14MM	89	117

Bolt Torque Specifications
 Torque in Foot-Pounds per Inch Bolts

Bolt Size	Grade 5	Grade 8
1/4"	10	14
5/16"	19	29
3/8"	33	47
7/16"	54	78
1/2"	78	119
5/8"	154	230

Confirm the towability and pre-towing procedures for your vehicle with the owner's manual or contact the vehicle's manufacturer for specific towing procedures.

! WARNING

Failure to read and follow these instructions could result in separation of the towed vehicle from the tow bar, causing property damage, loss of towed vehicle, personal injury or death.

BX1648

1999-03 Chevrolet Malibu 2003-05 Chevrolet Malibu Classic 1999-02 Pontiac Grand Am 1999-03 Oldsmobile Alero Installation Instructions

Parts List

Ref. No.	Qty.	Part #	Description
1	1	61-5820	Weldment, Baseplate, BX1648
2	10	61-5208	Weldment 3/8-16 Nutplate
3	2	62-3469	Attachment, Assembly, SF/LB (R)
4	2	201-0368	3/8-16 x 1 1/4" Bolt, Grade 5, ZP
5	8	201-0440	3/8-16 x 1/ 1/2" Bolt, Grade 5, ZP
6	10	203-0010	3/8" Lock Washer, ZP
7	2	201-0979	#12-14 x 1" Self Drilling Screw, ZP
8	2	101-5822	Adapter, 4 Way Connector
9	2	201-0192	#10-32 x 1/2" Slot, Rd. Hd. Screw
10	2	203-0054	#10 Lock Washer
11	2	202-0047	#10-32 Hex Nut
12	2	201-0655	6MM-1" x 30MM Hex Bolt, Grd. 8.8, (Not Shown, replacement for horn bracket and washer reservoir)
13	2	290-0437	Cap Plug, Black, Not Shown

Tools Required

9/16" Socket
7MM Socket
10MM Socket
13/32" Drill Bit
Vise Grips
Loctite® RED

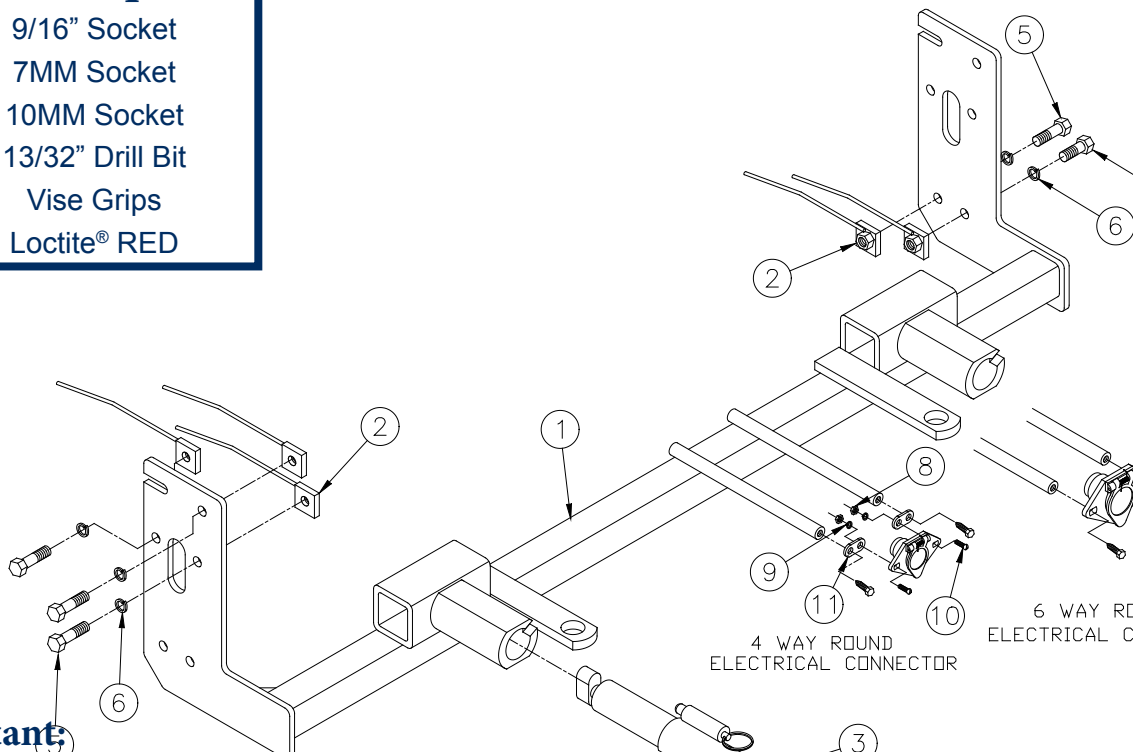

Important:

Use only genuine factory replacement parts on your baseplate. Do **NOT** substitute homemade or non-typical parts. If a bolt is lost or in need of replacement, for your safety and the preservation of your baseplate, be sure to use a replacement bolt of the same grade (In most cases it will be Grade 5, please reference the parts list above). Replacement parts may be ordered through your nearest Blue Ox® Dealer or Distributor.

BX1648

1999-03 Chevrolet Malibu 2003-05 Chevrolet Malibu Classic 1999-02 Pontiac Grand Am 1999-03 Oldsmobile Alero **Installation Instructions**

Removable Tabs:

Due to the design of the removable tabs, the RangeFinder II and Ambassador tow bars can not be used. Adapters, except for the BX8833 and the BX88151, can not be used with this baseplate.

Installation Notes:

The front fascia, horn bracket, headlight assemblies and windshield washer reservoir are removed and reinstalled for the baseplate installation. Drilling is required. Trimming of the fascia is required.

The dimensional variations between otherwise identical vehicles can be considerable. While the baseplate was designed for easy installation, it may be necessary to tailor the baseplate slightly to compensate for auto manufacturer's tolerances. These minor adjustments may include filing a hole slightly, bending electrical rods, and/ or bending end plates.

The BX8869 Bulb and Socket Wiring Kit is recommended for this vehicle.

Installation Instructions:



1. Remove the five pushpins from the top side of the fascia. Set the pushpins aside to be reinstalled later.



2. Just behind the headlight assemblies are two white clips. Pull the clips up, unplug the electrical connections, and remove the headlight assembly. Do this to both sides of the vehicle.

BX1648

1999-03 Chevrolet Malibu 2003-05 Chevrolet Malibu Classic 1999-02 Pontiac Grand Am 1999-03 Oldsmobile Alero **Installation Instructions**

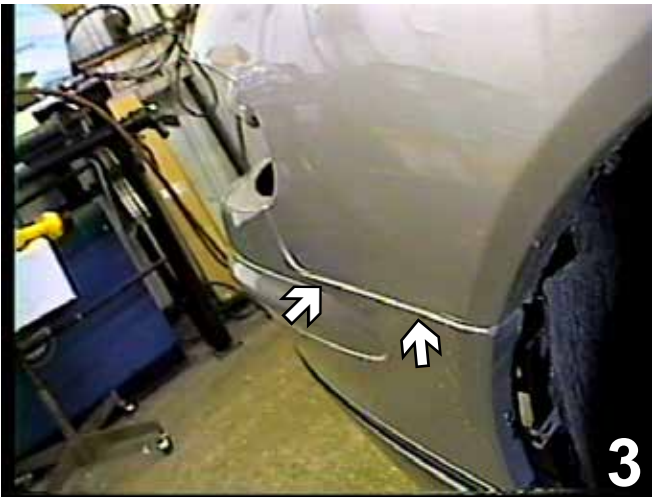

3. Using the 10MM socket, remove two metric bolts, just behind the headlight on the fascia corner. Set the metric bolts aside to be reinstalled later. Do this to both sides of the vehicle.



4. Using the 7MM socket, remove two metric bolts, forward of the front tire in the wheel well. Set the metric bolts aside to be reinstalled later. Do this to both sides of the vehicle.



5. Using the 7MM socket, remove eight metric bolts from the bottom side of the fascia. Remove five pushpins from this same location. Set the metric bolts and pushpins aside to be reinstalled later. Do this to both sides. Pull the fascia forward and set it aside to be reinstalled later.

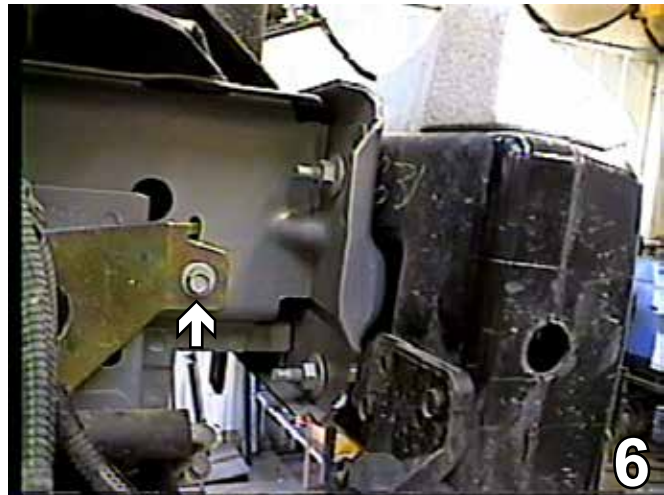

6. Using a 6MM socket, remove the metric bolt from the horn bracket. Unplug and set aside to be reinstalled later.

BX1648

1999-03 Chevrolet Malibu 2003-05 Chevrolet Malibu Classic 1999-02 Pontiac Grand Am 1999-03 Oldsmobile Alero **Installation Instructions**



7. Remove four metric bolts from windshield reservoir, unplug the hose and electrical connections and set aside to be reinstalled later.

BE SURE TO USE LOCTITE® RED ON ALL BOLTS BEFORE TIGHTENING. TIGHTEN ALL BOLTS ACCORDING TO THE TORQUE CHART ON THE FRONT PAGE OF THESE INSTRUCTIONS OR ON PAGE 3 OF THE BASEPLATE TOWING GENERAL INSTRUCTIONS.

9. Reinstall the horn bracket and windshield washer reservoir. Use the 6MM-1" x 30MM hex bolt to replace the upper reservoir and the horn bracket metric bolts.

Be sure that ALL electrical connections are plugged in properly and functioning BEFORE installing the fascia.

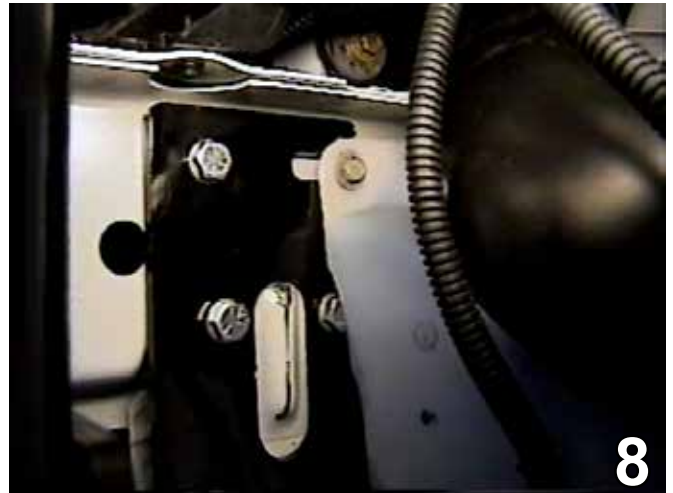

8. Slide the baseplate onto the frame to align with the frame knob and reservoir bolt location on driver's, clamp in place with the vise grips. Set the fascia in place, adjust the baseplate to come through the opening and remove the fascia. Drill all holes with the 13/32" drill bit while assuring that the baseplate is level. Insert the 3/8-16 nutplates into the frame to align with the drilled holes. Tighten 3/8-16 x 1 1/2" bolt, 3/8-16 x 1 1/4" bolt and the 3/8" lock washer.

Install the tow bar and safety cables according to the instructions included in their packages.

Do NOT substitute other devices if the tow bar pin and clip are lost.

Dealer or Installer: be certain the customer receives the instruction sheet.

BX1648

1999-03 Chevrolet Malibu
2003-05 Chevrolet Malibu Classic
1999-02 Pontiac Grand Am
1999-03 Oldsmobile Alero
Installation Instructions

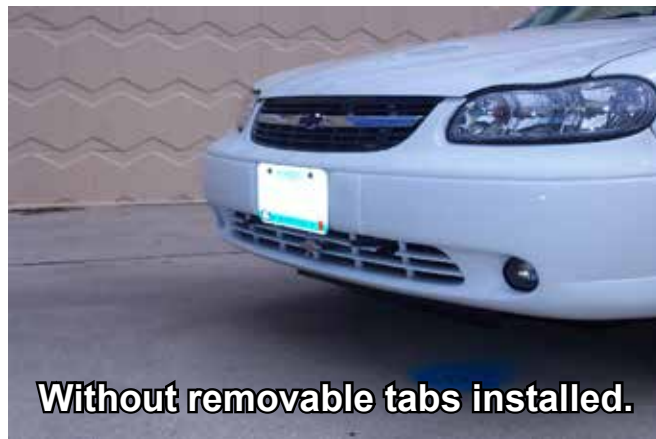

General Information

1. It is the owner's responsibility to inspect all towing equipment for cracked welds, missing or worn parts and loose bolts before each towing trip. Be sure to use Loctite® Red on all bolts and tighten to the recommended specifications.
2. It is the owner's responsibility to hook up all towing equipment per manufacturer's instructions/ recommendations.
3. Remove the attachment tabs when not in use (if applicable).

Notice To Baseplate Installer

1. It is YOUR responsibility to watch for:

- Oil cooler and air conditioner lines
- Electrical wires and hoses
- Missing parts or attaching points on the frame

** If the baseplate is improperly installed and is against a wire or hose, it could cause fluid leaks or electrical shorts some time after the actual baseplate installation.

Permanent Baseplate Safety Cable Installation

Permanent baseplate safety cables are strongly recommended when towing a vehicle with a tow bar. The principle function of the permanent baseplate safety cables is to prevent the towed vehicle from breaking loose in the event the connection between the frame of the towed vehicle and the baseplate fails or becomes disconnected. The cables must be connected from the baseplate to the frame rail or cross member of the vehicle's frame. The illustrations below show the possible arrangements recommended by Blue Ox®. Each permanent baseplate safety cable must have an adequate weight rating for the towing system. The weight rating of the two (2) cables together will not qualify.

Do not mount the permanent baseplate safety cables against wires, hoses or brake lines.

These permanent baseplate safety cables should remain installed as long as the baseplate is installed on the vehicle. Permanent baseplate safety cables are to be used in conjunction with, and NOT a replacement for legally required safety cables attaching the towed vehicle to the towing vehicle.

OPTION #1

Permanent Baseplate Safety Cables to Cross Member or Frame of Towed Vehicle.

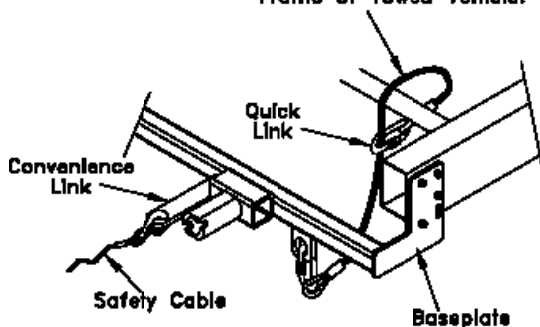

OPTION #2

Permanent Baseplate Safety Cables to Cross Member or Frame of Towed Vehicle.

