



BX1128

2011-13 Dodge Durango

2011-18 Jeep Grand Cherokee

(Includes Trail Rated & Adaptive Cruise Control)

Installation Instructions

Please read BOTH these Installation Instructions and the General Instructions prior to installing or operating this equipment.



Attachment Tab Height: 17-1/2"

Attachment Tab Width: 34-3/4"

1. Blue Ox® towing products and accessories are intended to be installed by Blue Ox® Dealers who are familiar with our products and have the equipment and knowledge necessary to do "fit work".
2. Many Blue Ox® baseplates are designed to use existing holes and hardware to mount the baseplate to the towed vehicle. Even though bolts are there, do not assume they are adequate for baseplate mounting. Always use the hardware supplied in the hardware kit and existing hardware as specified in the installation instructions.



WARNING

Failure to read and follow these instructions could result in separation of the towed vehicle from the tow bar, causing property damage, loss of towed vehicle, personal injury or death.

Reference your vehicle owner's manual for manufacturer's towing specifications.

BX1128

2011-13 Dodge Durango 2011-18 Jeep Grand Cherokee

Installation Instructions

Bolt Torque Specifications		
Torque in Foot-Pounds for Inch Bolts		
Bolt Size	Grade 5	Grade 8
1/4"	10	14
5/16"	19	29
3/8"	33	47
7/16"	54	78
1/2"	78	119
5/8"	154	230
3/4"	257	380

Bolt Torque Specifications		
Torque in Foot-Pounds for Metric Bolts		
Bolt Size	Grade 8.8	Grade 10.9
6MM	6	8
8MM	16	22
10MM	31	40
12MM	54	70
14MM	89	117
16MM	161	230
18MM	222	318

Instruction Notes: The fascia, plastic shielding and windshield washer fluid reservoir are removed and reinstalled for the baseplate installation. Some drilling and trimming is required. If equipped, the tow hooks are removed for baseplate installation and not reinstalled.

Place all components that are removed on a flat, sturdy surface. All items will be reinstalled unless otherwise noted after the baseplate is installed.

The dimensional variations between otherwise identical vehicles can be considerable. While the baseplate was designed for easy installation, it may be necessary to tailor the baseplate slightly to compensate for vehicle manufacturer's tolerances.

The BX8869 Tail Light Wiring Kit is recommended for this vehicle.

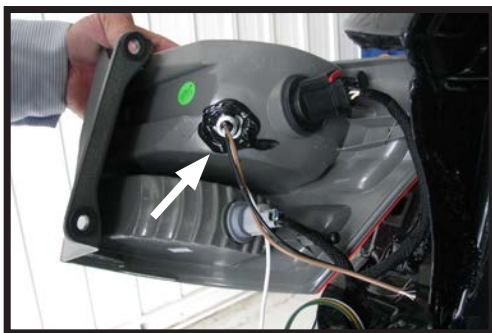

Drill a hole according to the tail light wiring kit instructions.



NOTICE

- Handling of some cosmetic parts when installing this product may require the use of protective covers, rags, specialty tools, etc. to prevent damage.
- When using power drills be aware of the dangers of torque and drill bit length.
- When using a reciprocating saw be aware of objects behind the cutting surface.
- Use a good quality paint to spray cut edges of frame to prevent rusting.
- Be sure that **ALL** electrical connections are plugged in and accessories are functioning properly before reinstalling the fascia.
- The baseplate is computer tested to your vehicle's GVWR, exceeding this weight will void the manufacturer's warranty.
- Be sure to use a sufficient amount of Loctite® Red on all bolt threads before tightening. Tighten all bolts according to the torque chart provided.
- Dealer or installer be certain the user receives these instruction sheets.
- If the baseplate is in an accident, it must be replaced. **DO NOT** use it again! An accident can cause unseen damage and using it again could result in more damage or serious injury. **DO NOT** use the baseplate if it is damaged or missing parts.

BX1128
2011-13 Dodge Durango
2011-18 Jeep Grand Cherokee
Installation Instructions

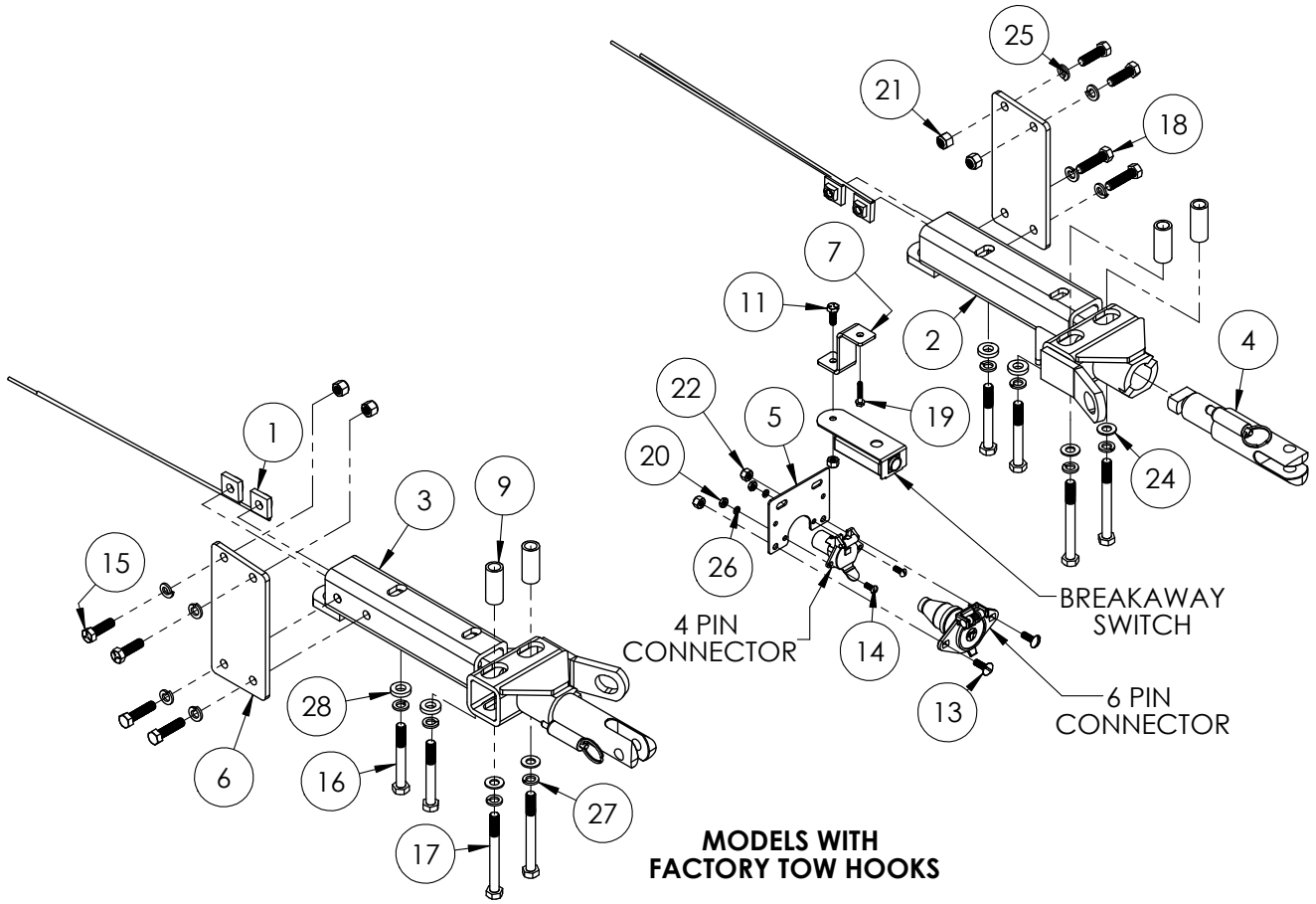

**MODELS WITH
FACTORY TOW HOOKS**

- Tools Required**
- Large Vise Grip
 - Flat Screwdriver
 - Utility Knife
 - Torque Wrench
 - Drill
 - Plastic Pop Rivet Gun
 - Tape Measure
 - Loctite® RED
 - 1/4" Drill Bit
 - 3/8" Drill Bit
 - 8MM Socket
 - 10MM Socket
 - 13MM Socket
 - 16MM Socket
 - 30MM Socket
 - 30MM Wrench
 - 9/16" Socket
 - 9/16" Wrench

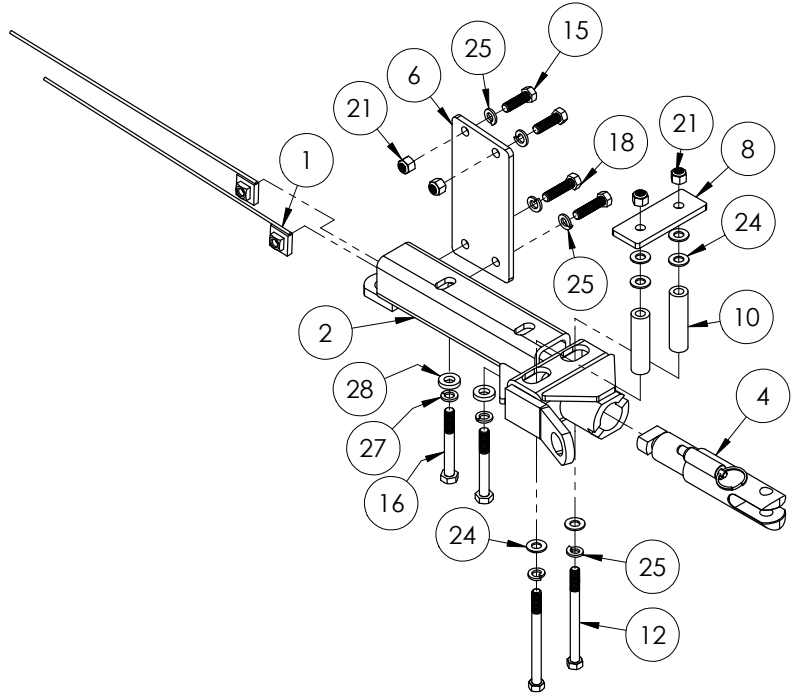

**MODELS WITHOUT
FACTORY TOW HOOKS**

BX1128
2011-13 Dodge Durango
2011-18 Jeep Grand Cherokee
Installation Instructions

Item No.	Part No.	Description	Qty.
1.....	61-5208.....	3/8"-16 Nut Plate w/ 14" Wire	4
2.....	61-6770.....	BX1128 DS Baseplate.....	1
3.....	61-6771.....	BX1128 PS Baseplate.....	1
4.....	62-3468.....	Attachment Tab Assembly with Hole	2
5.....	101-6845.....	Electrical Bracket.....	1
6.....	101-7577.....	BX1128 Support Plate	2
7.....	102-7056.....	Breakaway Bracket	1
8.....	102-7106.....	Spacer Plate.....	2
9.....	107-3184.....	Spacer Tube 3/4"Ø x 1-23/32".....	4
10.....	107-3191.....	Spacer Tube 3/4"Ø x 2-3/4".....	4
11.....	201-0050.....	1/4"-20 x 3/4" Hex Head Bolt, Grade 5, ZP	1
12.....	201-0077.....	3/8"-16 x 4-1/2" Hex Head Bolt, Grade 5, ZP	4
13.....	201-0111.....	1/4"-20 x 3/4" Slot Head Truss Screw	2
14.....	201-0192.....	#10-32 1/2" Round Slotted Head Screw.....	2
15.....	201-0368.....	3/8"-16 x 1-1/4" Hex Head Bolt, Grade 5, ZP	4
16.....	201-0429.....	10MM-1.5 x 80MM Hex Head Bolt, Grade 8.8, ZP.....	4
17.....	201-0432.....	10MM-1.5 x 100MM Hex Head Bolt, Grade 10.9, ZP.....	4
18.....	201-0440.....	3/8"-16 x 1-1/2" Hex Head Bolt, Grade 5, ZP	4
19.....	201-0654.....	#10-16 x 1" Self Drilling Screw	1
20.....	202-0047.....	#10-32 Hex Nut	2
21.....	202-0090.....	3/8"-16 Hex Nylon Insert Lock Nut, ZP.....	8
22.....	202-0102.....	1/4"-20 Hex Nylon Nut, ZP	3
23.....	203-0002(not shown).....	5/16" Flat Washer, ZP.....	3
24.....	203-0003.....	3/8" Flat Washer, ZP.....	16
25.....	203-0010.....	3/8" Lock Washer, ZP	12
26.....	203-0054.....	#10 Lock Washer, ZP	2
27.....	203-0104.....	10MM Lock Washer, ZP	8
28.....	203-0195.....	3/8" x 7Ga Washer	4
29.....	226-0049(not shown).....	Class IV Safety Cables.....	2
30.....	229-0512(not shown).....	1/2" Quicklink, ZP	2
31.....	229-0536(not shown).....	6.3MM Plastic Rivet.....	4
32.....	290-0437(not shown).....	Black Cap Plug Receiver.....	2

Important:

Use only genuine factory replacement parts on your baseplate. Do **NOT** substitute homemade or non-typical parts. If a bolt is lost or in need of replacement, for your safety and the preservation of your baseplate, be sure to use a replacement bolt of the same grade (In most cases it will be Grade 5, please reference the parts list above). Replacement parts may be ordered through your nearest Blue Ox® Dealer or Distributor. Failing to follow and/or altering these installation instructions in either installation or required equipment will void the manufacturer's warranty. Towing behind a non-motorized vehicle will void the warranty.

BX1128
2011-13 Dodge Durango
2011-18 Jeep Grand Cherokee
Installation Instructions

Fascia Removal: 2011-13 Dodge Durango / Jeep Grand Cherokee



1. On the bottom side of the fascia, remove the four (4) push pins.



2. Using a utility knife, remove the two (2) plastic rivets from outer edge of the wheel well. Then release the knob at the bottom inner edge of the wheel well, by turning 90°. Do this on both sides of the vehicle.

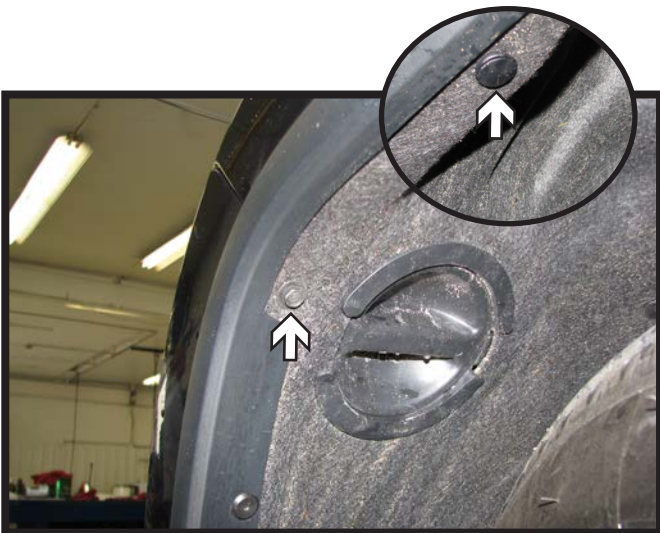

3. Along the upper edge of the wheel well, using a 10MM socket, remove the screw. Then remove the push pin further up (inset). Do this on both sides of the vehicle.



4. Pull the top corners of the fascia out releasing the clips behind. Continue working inward towards the grille releasing the clips under the headlights and grille. Set the fascia aside.

Continue to Step #1 on page #8

BX1128
2011-13 Dodge Durango
2011-18 Jeep Grand Cherokee
Installation Instructions
Fascia Removal: 2014 & up Jeep Grand Cherokee



1. On the topside of the fascia, remove the two (2) push pins.



2. Using a utility knife, remove the two (2) plastic rivets from outer edge of the wheel well (white). Then using a 10MM socket, remove the upper screw (gray). Do this on both sides of the vehicle.



3. Underneath the bumper, remove the two (2) push pins. Do this on both sides of the vehicle.



4. On the underside of the fascia, release the fascia clips by turning 90°. There is one (1) towards the middle (white) and one (1) towards the outer edge by the tire (gray). Do this on both sides of the vehicle.

BX1128
2011-13 Dodge Durango
2011-18 Jeep Grand Cherokee
Installation Instructions
Fascia Removal: 2014 & up Jeep Grand Cherokee continued



5. For models with headlight sprayers, pull out the square piece to allow the sprayer to be disconnected (left). Press down on the indicated clips on both sides of the bracket to disconnect and remove to be reinstalled later (right). Do this on both sides of the vehicle.

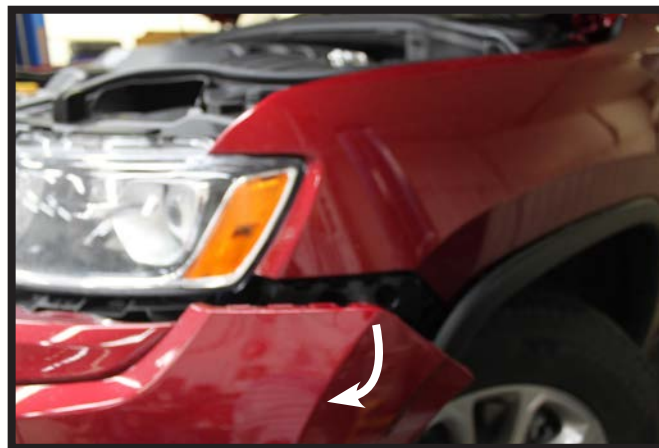

6. Pull the top corners of the fascia out releasing the clips behind. Continue working inward towards the grille releasing the clips under the headlights. Set the fascia aside.

Note: On Summit/High Altitude models push in on the corners to release the clips and then pull downward and out.

BX1128
2011-13 Dodge Durango
2011-18 Jeep Grand Cherokee
Installation Instructions
Baseplate Installation All Models

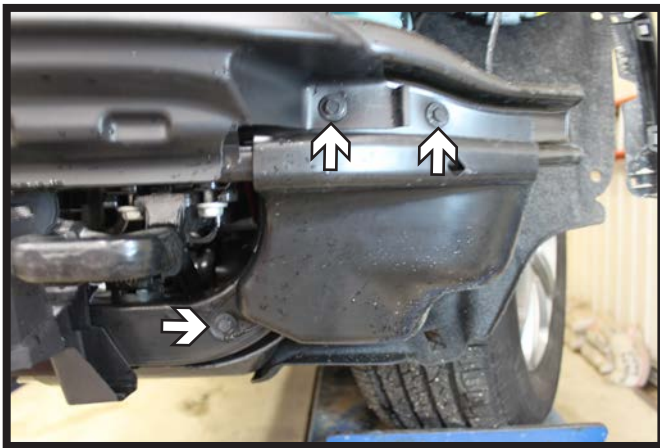

1. If equipped on your model of vehicle, the lower plastic shielding will need to be removed. Using a 10MM socket, remove the three (3) bolts from the shielding. Do this on both sides of the vehicle.



2. In the engine compartment, remove the push pin from the washer reservoir filler tube neck.

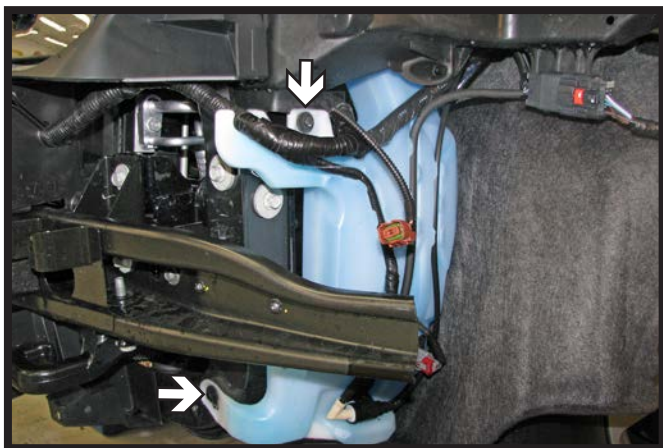

3. Using a 8MM socket, remove the two (2) bolts from the washer fluid reservoir. Disconnect/plug all lines and set reservoir aside.

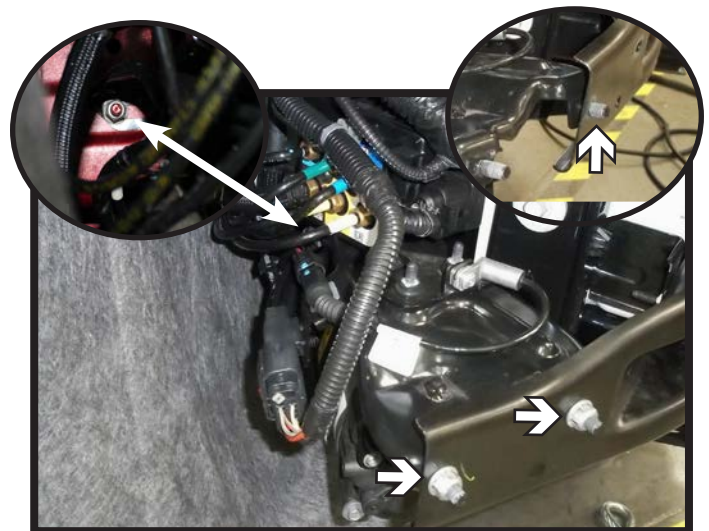

4. On models equipped with a compressor, using a 10MM or 13MM socket, remove the two (2) nuts from the bumper and one (1) nut from the frame behind the compressor (left inset). Move the compressor away from the frame. Put the inner stud into the outer bumper hole and thread on a nut to secure in position (right inset). This will allow room for baseplate installation.

BX1128
2011-13 Dodge Durango
2011-18 Jeep Grand Cherokee
Installation Instructions

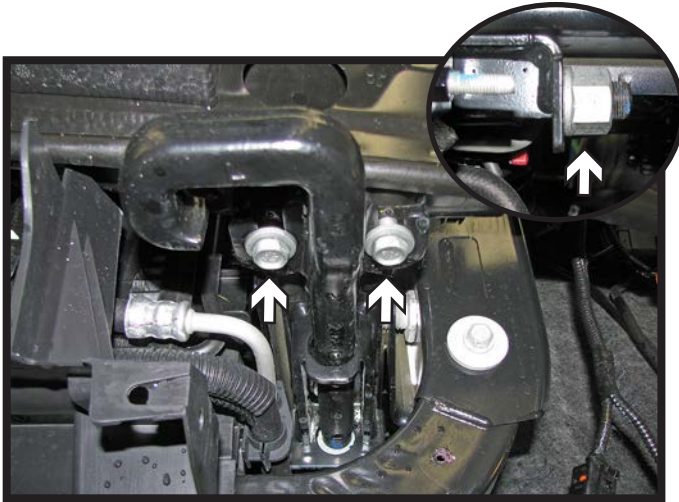

5. **Models equipped with tow hooks:** Using a 16MM socket, remove the two (2) bolts from the front side. Then using a 30MM socket or wrench, remove the nut from the backside of the tow hook. Remove the tow hook from the vehicle. Do this on both sides of the vehicle.



6. **Models equipped with tow hooks:** Using a 16MM socket, remove the two (2) bolts from the tow hook bracket. Remove the tow hook bracket from the vehicle. Do this on both sides of the vehicle.

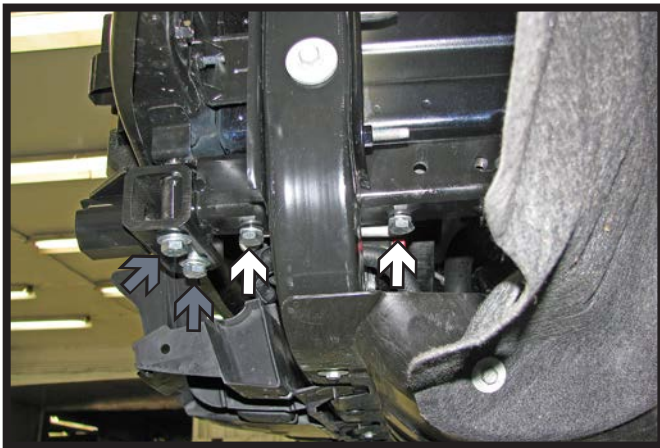

7. **Models equipped with tow hooks:** Slide the baseplate into position on the frame. Install two (2) 10MM-1.5 x 80MM bolts with 10MM lock washers into the bottom holes (white). Install a 3/4"Ø x 1-23/32" spacer tube with a 10MM-1.5 x 100MM bolt, 10MM lock and flat washer thru the spacer into the frame into both the front holes (gray). Tighten all hardware. Do this on both sides of the vehicle.

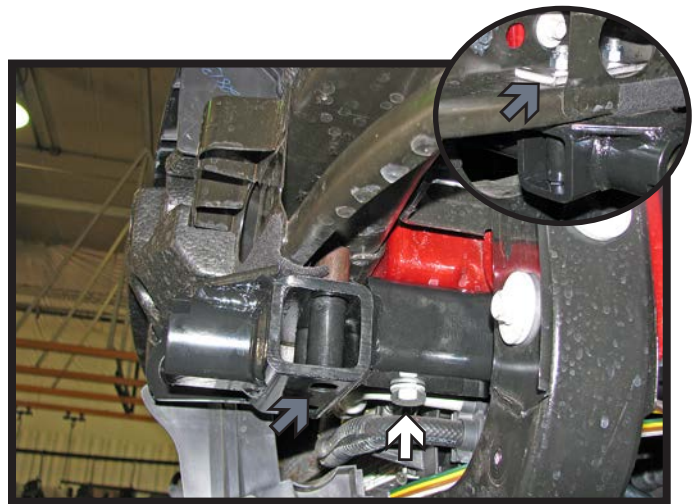

8. **Models equipped without tow hooks:** Slide the baseplate into position on the frame. Install two (2) 3/4"Ø x 2-3/4" spacer tubes into the front holes (gray). Then install two (2) 10MM-1.5 x 80MM bolts with 10MM lock washers into the bottom holes (white). Insert 3/8"-16 x 4-1/2" bolts with 3/8" lock washers into the front holes with the spacer plate and 3/8"-16 nuts on top of bumper (inset) Use 3/8" flat washers if needed in between the spacer and bumper. Tighten all hardware. Do this on both sides of the vehicle.

BX1128
2011-13 Dodge Durango
2011-18 Jeep Grand Cherokee
Installation Instructions

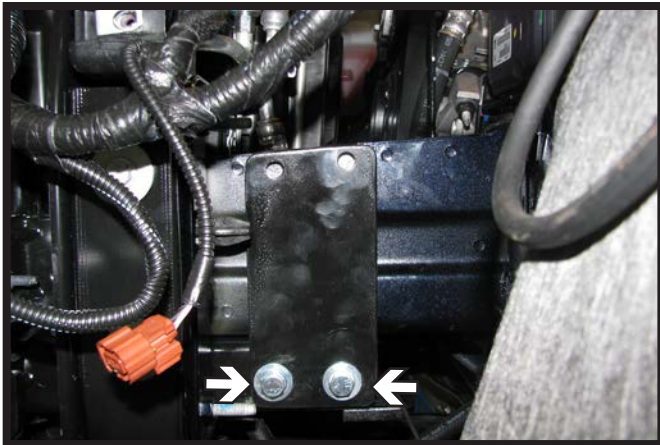

9. With the taper to the front, install the support plate onto the baseplate. Insert the 3/8"-16 x 1-1/2" bolts with 3/8" lock and flat washers into the holes and the 3/8" nut plates on the inside of the baseplate. Flush the top of the plate with the frame and tighten all hardware. Do this on both sides of the vehicle.

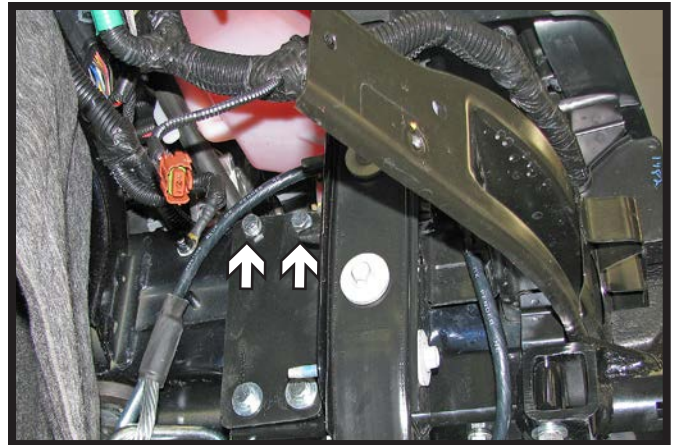

10. Using a 3/8" drill bit, drill the top two (2) holes of the support plate thru the frame. Install 3/8"-16 x 1-1/4" bolts with 3/8" lock washers and 3/8"-16 lock nuts. Do this on both sides of the vehicle. Fully tighten all hardware.

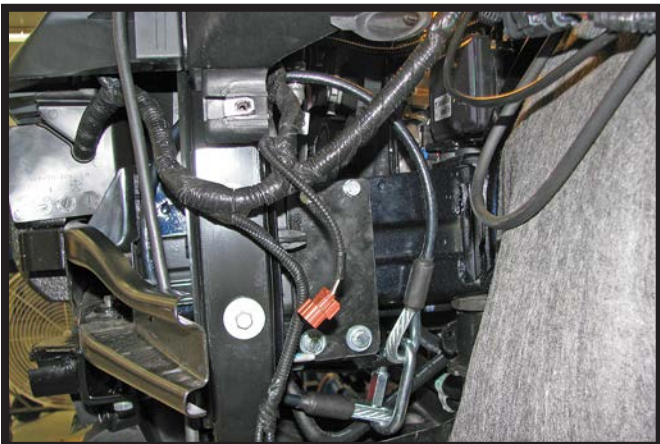

11. Attach the permanent baseplate safety cables to the provided convenience link on the baseplate. The photo shows the recommended installation of the cables to frame of vehicle. Additional options may interfere with suggested mounting; in this case, secure the cables to a solid piece of the frame as described in the General Information sheet. Be sure the safety cables do not rub against any hoses or moving parts. Do this on **BOTH** sides of the vehicle.

BX1128
2011-13 Dodge Durango
2011-18 Jeep Grand Cherokee
Installation Instructions



12. Loosely reinstall the compressor, checking for clearance around the baseplate. If needed shim the compressor away from the baseplate with 5/16" washers. This will keep the compressor from vibrating against the baseplate.



13. Reinstall the washer fluid reservoir and plastic shielding.

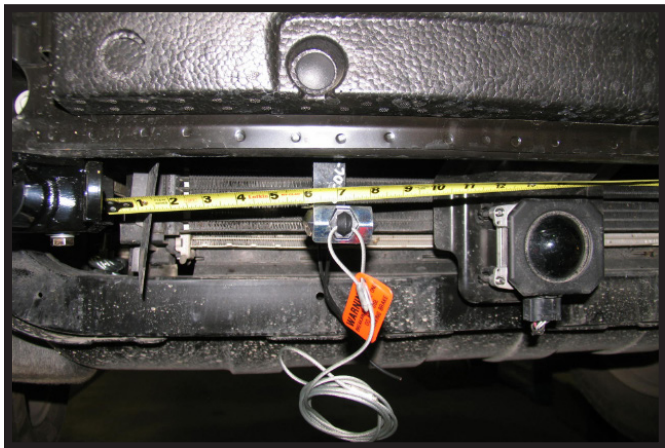

14. **Optional Breakaway:** Measure over approximately 7" from the convenience link or in the desired location, install the bracket to the bumper with a #10-16 x 1" self drilling screw. Attach the breakaway to the bracket with a 1/4"-20 x 3/4" bolt and 1/4"-20 lock nut.



15. Install the electrical bracket to the fascia at the desired location and bent to the desired angle. With a 1/4" drill bit drill out the two (2) mounting holes thru the fascia and attach the bracket to the fascia with 1/4"-20 x 3/4" bolts and 1/4"-20 lock nuts.

BX1128
2011-13 Dodge Durango
2011-18 Jeep Grand Cherokee
Installation Instructions

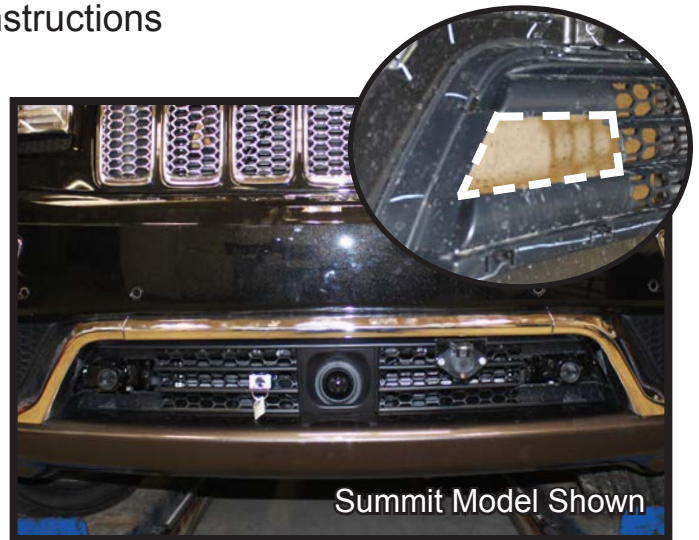

16. Hold the fascia as close to its original position as possible, mark and trim the fascia around the convenience links and attachment tabs. Reinstall the fascia. Using the plastic pop rivet gun, replace the two (2) rivets in the wheel well. Do this on both sides of the vehicle.

Note: Summit/High Altitude models have a different style fascia with no tow hook pockets on the fascia. It is recommended to trim a preliminary area the approximate size or smaller as shown in the right inset picture and test fit/trim as needed to fit around the convenience links and attachment tabs.



General Information

1. **It is the owner's responsibility to inspect all towing equipment for cracked welds, missing or worn parts and loose bolts before each towing trip.** Be sure to use Loctite® Red on all bolts and tighten to the recommended specifications.
2. **It is the owner's responsibility to hook up all towing equipment per manufacturer's instructions/ recommendations.**
3. Remove the attachment tabs when not in use (if applicable).

Notice To Baseplate Installer

1. It is YOUR responsibility to watch for:

- Oil cooler and air conditioner lines
- Electrical wires and hoses
- Missing parts or attaching points on the frame

** If the baseplate is improperly installed and is against a wire or hose, it could cause fluid leaks or electrical shorts some time after the actual baseplate installation.

Permanent Baseplate Safety Cable Installation

Permanent baseplate safety cables are strongly recommended when towing a vehicle with a tow bar. The principle function of the permanent baseplate safety cables is to prevent the towed vehicle from breaking loose in the event the connection between the frame of the towed vehicle and the baseplate fails or becomes disconnected. The cables must be connected from the baseplate to the frame rail or cross member of the vehicle's frame. The illustrations below show the possible arrangements recommended by Blue Ox®. Each permanent baseplate safety cable must have an adequate weight rating for the towing system. The weight rating of the two (2) cables together will not qualify.

Do not mount the permanent baseplate safety cables against wires, hoses or brake lines.

These permanent baseplate safety cables should remain installed as long as the baseplate is installed on the vehicle. Permanent baseplate safety cables are to be used in conjunction with, and NOT a replacement for legally required safety cables attaching the towed vehicle to the towing vehicle.

Option #1

(Baseplates with Convenience Link Tabs)



Option #2

(Baseplates with out Convenience Link Tabs)

