



Strong As An Ox™

BX1117 Installation Instructions 1996-98 Jeep Grand Cherokee (All Models)

A BX88116 Adapter is needed when using a Blue Ox car mounted tow bar. If vehicle has tow hooks, they need to permanently be removed.

1. The frame mounts (Items 1 and 2) bolt to existing holes in the main frame of the vehicle. Locate and remove the two bolts securing the radiator cross member to the frame on each side of the vehicle. Also remove the plastic splash guard retainer located 1 1/2" behind the rear cross member bolt. This will expose a frame weldnut.
2. Unbolt the tubular cowl support from the radiator cross member and loosen the bolts that attach it to the cowl. These are located beneath the splash panel.
3. Insert each frame mount (Items 1 and 2) through the lower outside grill openings of the bumper molding and place over the bolt holes mentioned in step 2. Bolt the frame mounts to the frame using the 3-10mm x 1.5 x 40mm bolts and washers provided (Items 12, 13 and 14). Use Loctite to ensure that the bolts do not loosen while the car is being towed. Do not tighten.

The dimensional variations between otherwise identical cars can be considerable. While the location and size of the holes in the baseplate were designed to allow for easy installation, it may be necessary to file a hole slightly.

4. Remove the lower plastic push pins on the lower bumper molding. Pull back on the bottom of the bumper molding and insert the main weldment (Item 1) up into the space between the bumper molding and the radiator. Line up the holes of the main weldment to the face of the frame mount plates as shown in the diagram on page 2. Use the 1/2 inch hardware (Items 8, 9, 16 and 11) as shown in the drawing on page two
5. Notice the small braces of the main weldment (Item 1) extending back to existing holes in the cross member below the radiator. Use the 3/8 inch hardware (Items 5, 6 and 7) provided. Tighten all bolts (according to the torque chart in the General Instruction Sheet). Use Loctite to ensure that the bolts do not loosen while the car is being towed.
6. Now bolt the extension braces (Item 4) to the back of the radiator cross member using the existing bolt in the cross member. Bolt the loose end of the flat support to the tab using a 3/8 x 1 1/2 bolt washers and nut provided (Items 5, 6, 10 and 7).
7. Replace the bumper moldings push pins.
8. Install the tow bar and safety cables according to the instructions included in their packages. Do not substitute other devices if the tow bar pin and clip are lost.
9. **DEALER OR INSTALLER: BE CERTAIN THE USER RECEIVES THE INSTRUCTION SHEET.**

Operation

To install the tow bar connectors, push the connector all the way in through the bumper mount with the release pin housing up. Rotate the connector until the locking pin engages. To remove the tow bar connectors from the car, pull on the ring to release the lock pin and rotate the connector. Pull the connector straight ahead to remove. Be sure to rotate the connectors so the pin assemblies point up.

Tools Required

16MM Socket	17MM Socket
18MM Socket	3/4" Socket
Drill	Loctite
	Flathead Screwdriver

Parts List

Ref. No.	Qty.	Part No.	Description
1	1	61-5257	Drivers Side Frame Mount
2	1	61-5258	Passenger Side Frame Mount
3	2	61-5285	Weldment, 3/8 Bolt With Wire
4	1	61-5318	Baseplate, BX1117
5	2	62-3468	Removable Tabs, SF/SB
6	2	102-5583	Panel Brace
7	4	201-0051	1/2-13 x 1 1/2 Bolt, Grade 5, ZP
8	2	201-0192	#10-32 x 1/2 Slotted Screw, ZP
9	6	201-0410	10MM-1.5 x 35mm Bolt, Grade 8.8, ZP
10	2	201-0440	3/8-16 x 1 1/2 Hex Bolt, Grd 5, ZP
11	2	201-0979	#12-14 x 1" Self Drilling Screw, ZP
12	2	202-0047	#10 Hex Nut, ZP
13	2	202-0071	3/8-16 Hex Flange Whiz Lock Nut, ZP
14	4	202-0072	1/2-13, Hex Flange Whiz Lock Nut, ZP
15	2	203-0003	3/8 Flat Washer, ZP
16	4	203-0005	1/2 Flat Washer, ZP
17	2	203-0010	3/8 Lock Washer, ZP
18	4	203-0012	1/2 Lock Washer, ZP
19	2	203-0054	#10 Lock Washer, ZP
20	6	203-0103	10mm Flat Washer, ZP
21	6	203-0104	10MM Lock Washer, ZP
22	1	299-0685	4-Way Bracket
	2	226-0046	Baseplate Safety Cable, 36" CL III (Not Shown)
	2	229-0359	Quicklink, 3/8, ZP (Not Shown)
	6	229-0536	6.3MM Plastic Rivet (Not Shown)
	2	290-0437	Receiver, Cap Plug (BLK) (Not Shown)

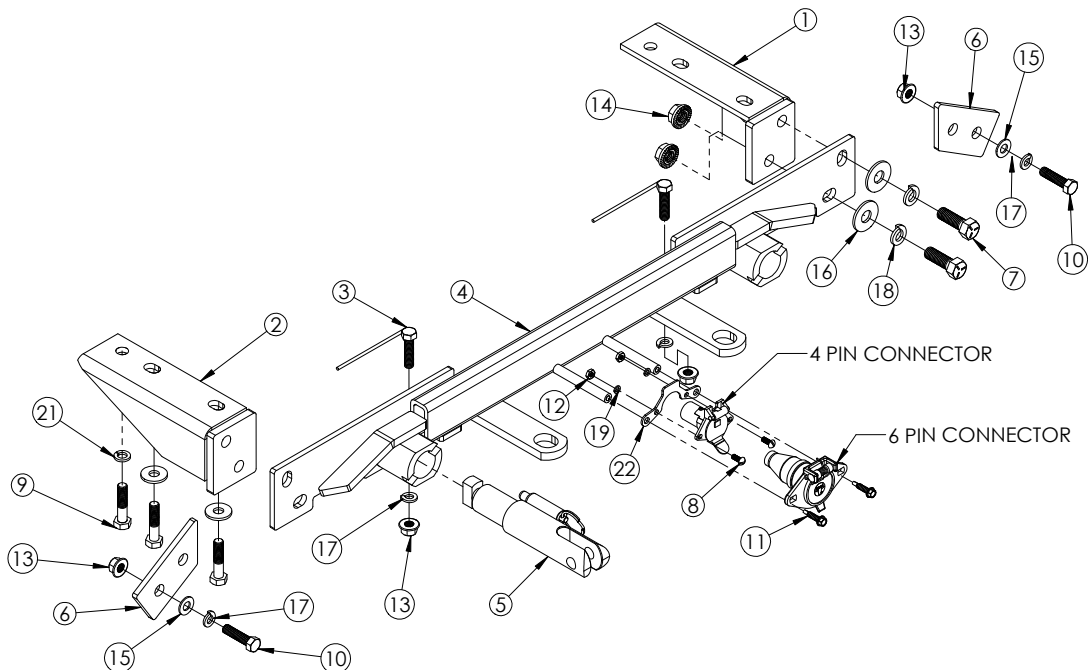

General Information

1. It is the owner's responsibility to inspect all towing equipment for cracked welds, missing or worn parts and loose bolts before each towing trip. Be sure to use Loctite® Red on all bolts and tighten to the recommended specifications.
2. It is the owner's responsibility to hook up all towing equipment per manufacturer's instructions/recommendations.
3. Remove the attachment tabs when not in use (if applicable).

Notice To Baseplate Installer

1. It is YOUR responsibility to watch for:

- Oil cooler and air conditioner lines
- Electrical wires and hoses
- Missing parts or attaching points on the frame

** If the baseplate is improperly installed and is against a wire or hose, it could cause fluid leaks or electrical shorts some time after the actual baseplate installation.

Permanent Baseplate Safety Cable Installation

Permanent baseplate safety cables are strongly recommended when towing a vehicle with a tow bar. The principle function of the permanent baseplate safety cables is to prevent the towed vehicle from breaking loose in the event the connection between the frame of the towed vehicle and the baseplate fails or becomes disconnected. The cables must be connected from the baseplate to the frame rail or cross member of the vehicle's frame. The illustrations below show the possible arrangements recommended by Blue Ox®. Each permanent baseplate safety cable must have an adequate weight rating for the towing system. The weight rating of the two (2) cables together will not qualify.

Do not mount the permanent baseplate safety cables against wires, hoses or brake lines.

These permanent baseplate safety cables should remain installed as long as the baseplate is installed on the vehicle. Permanent baseplate safety cables are to be used in conjunction with, and NOT a replacement for legally required safety cables attaching the towed vehicle to the towing vehicle.

Option #1

(Baseplates with Convenience Link Tabs)

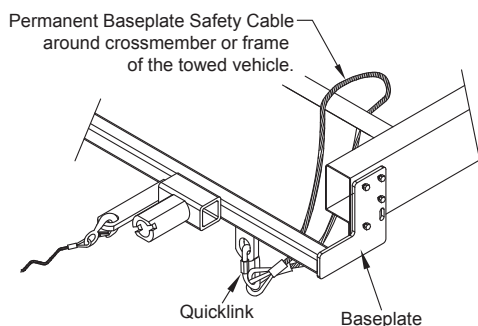

Option #2

(Baseplates with out Convenience Link Tabs)

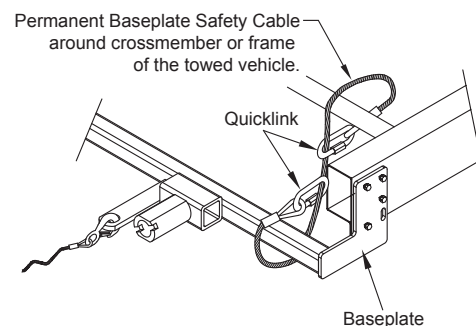

Rely only on high-grade trailer hitches and towing on our virtual shelves.