



INSTALLATION INSTRUCTIONS

**MODULAR RUGGED GRILLE GUARD FOR
2019 SILVERADO 1500
(Excl. Diesel models with DEF tanks & 2019 Silverado 1500 LD)
PART# RU-CHSI19-B**

PARTS LIST:

1	Main Body	18	8mm x 24mm OD x 2mm Flat Washers
1	Driver/Left Brush Guard	10	8mm x 25mm Button Head Allen Screws
1	Passenger/Right Brush Guard	8	8mm Nylon Lock Nuts
2	LED lamp Bracket	2	10mm Nylon Lock Nuts
1	Driver/Left GG Mounting Bracket	4	10mm x 27mm OD x 3mm Flat Washers
1	Passenger/Right GG Mounting Bracket	2	10mm x 30mm Hex Bolts
1	Driver/Left Top Bracket	4	12mm x 35mm Hex Bolts
1	Passenger/Right Top Bracket	14	12mm x 32mm OD x 3mm Flat Washers
2	Adhesive Backed Foam Tapes	10	12mm Hex Nuts
2	12-1.75mm x 30mm Double Bolt Plates	10	12mm Lock Washers
2	12-1.75mm x 35mm Single Bolt Plates	1	Allen Wrench S=5
		1	Allen Wrench S=2.5

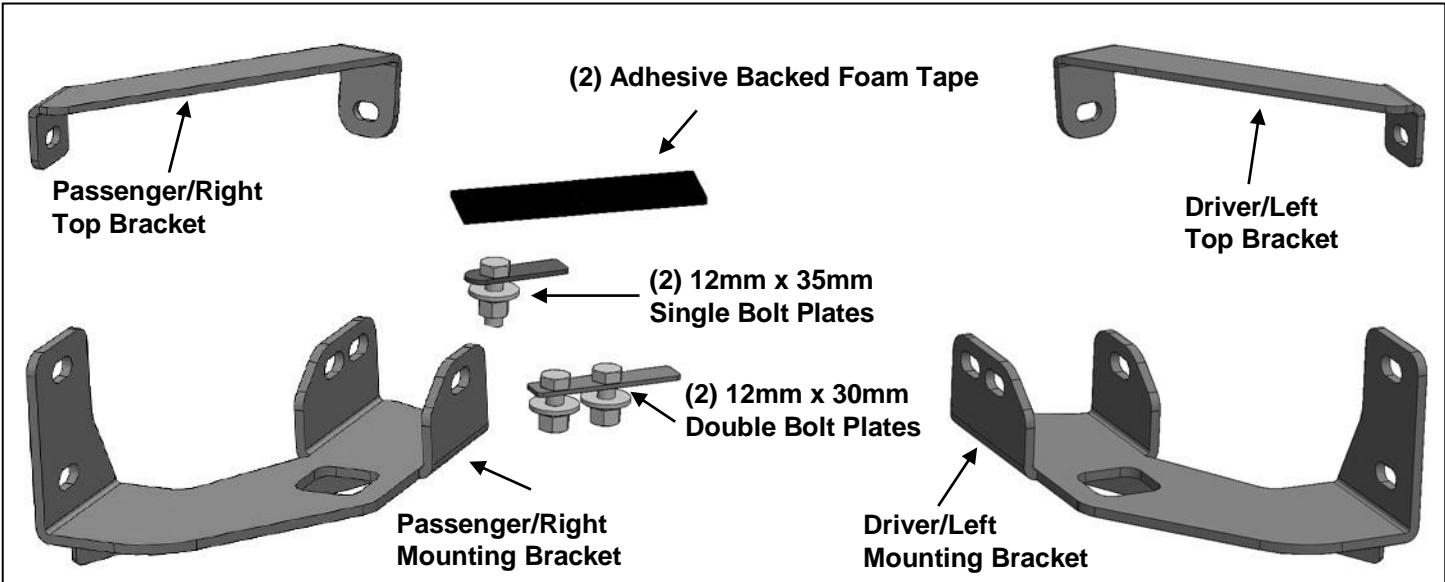

(2)LED lamp Bracket

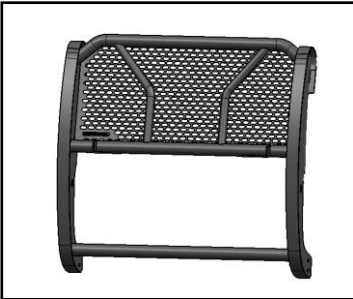

Main Body
For example only



Passenger/Right
Brush Guard
For example only

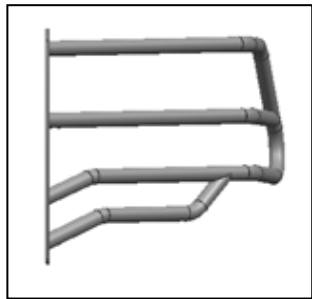

Driver/Left
Brush Guard
For example only

Please Noted:

1. Before you install the Grille Guard on the vehicle, please install the Driver/Left Brush Guard and Passenger/Right Brush Guard on the main body first.
2. Before you install the LED Lamp on the main body please install the LED Lamp Bracket first.
3. If you are not going to install a LED Lamp, the LED Lamp Bracket installation is unnecessary. For main body installation follow the instruction as bellow.

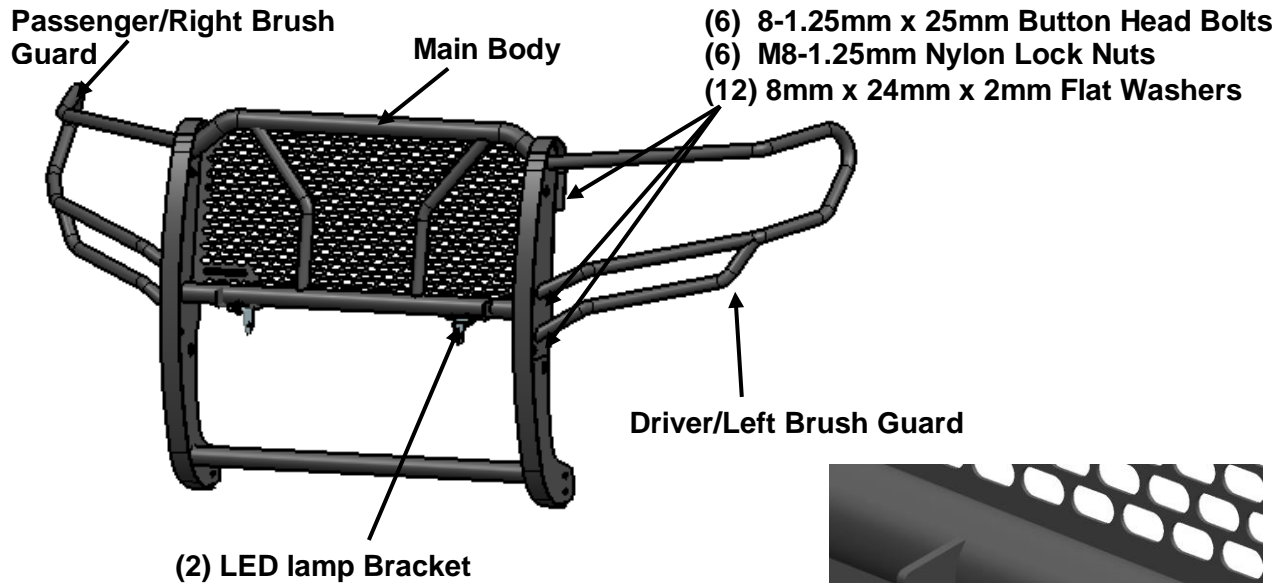

- (2) 8-1.25mm x 25mm Button Head Bolts
(2) M8-1.25mm Nylon Lock Nuts
(4) 8mm x 24mm x 2mm Flat Washers

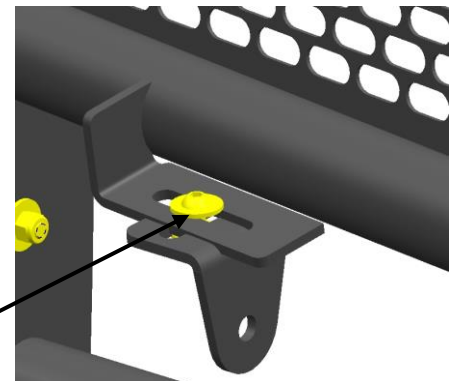

PROCEDURE:

REMOVE CONTENTS FROM BOX AND VERIFY ALL PARTS ARE PRESENT. READ INSTRUCTIONS CAREFULLY. CUTTING MAY BE REQUIRED. ASSISTANCE IS HIGHLY RECOMMENDED. INSTALLATION MAY INTERFERE WITH FRONT MOUNTED SENSORS.

1. Remove the factory tow hook hardware only if equipped, **(Figures 1 & 2)**. Leave the tow hooks in the frame.
2. Cut out the indented area in both sides of the plastic bumper insert to clear the Brackets as pictured, **(Figure 3 & 4)**. **NOTE:** Models with tow hooks will only require minor trimming to the bottom of the opening. **IMPORTANT:** Make several small cuts for best fit. Do not cut through the top or bottom edge of the panel.
3. Select the driver side Frame Mounting Bracket, **(Figure 6)**. Insert the Frame Bracket through the opening in the bumper. Line up the holes in the Frame Bracket with the holes in the frame for the tow hook.

Models with tow hooks:

- a. Reuse the factory hardware to attach the Bracket to the bottom of the frame.

Models without tow hooks:

- a. Select (1) 12mm Single Bolt Plate, **(Figures 6 & 7)**. Insert the Bolt Plate into the end of the frame, through the hole in the side of the frame and out through the Frame Bracket, Attach

the Frame Bracket to the Bolt Plate with (1) 12mm Flat Washer, (1) 12mm Lock Washer and (1) 12mm Hex Nut, **(Figure 8)**. Snug but do not tighten at this time.

- b. Select (1) 12mm Double Bolt Plate, **(Figures 6 & 9)**. Attach the Frame Bracket to the Bolt Plate with (2) 12mm Flat Washers, (2) 12mm Lock Washers and (2) 12mm Hex Nuts, **(Figure 10)**. Snug but do not fully tighten hardware at this time.
 4. Repeat **Steps 2 & 3** to install the passenger/right Frame Mounting Bracket.
 5. Open the hood and remove the cover between the top of the radiator and the grille, **(Figure 11)**.
 6. Carefully remove the grille from the vehicle. **NOTE:** Grille is held in place with screws at the top and several clips. Remove the screws and firmly pull the grille straight out from the vehicle to release the grille from clips, **(Figure 12)**.
 7. Move up to the top of the bumper. Select the Driver/left Top Bracket. Apply a layer of the included Adhesive Backed Foam Tame to the bottom of the Bracket, **(Figure 13)**. Trim Foam for best fit.
 8. Locate the (2) factory hex bolts attaching the top of the bumper to the inner bumper bracket. Remove the outer hex bolt, **(Figure 14)**. Reuse the factory hex bolt to attach the Top Bracket to the back of the bumper, **(Figure 15)**. Do not tighten hardware at this time.
 9. Repeat **Steps 7 & 8** to install the passenger/right Top Bracket, **(Figure 16)**.
 10. With assistance, hold the Grille Guard up in position on the outside of the Mounting Brackets, **(Figures 16 & 17)**. Attach the Grille Guard to the Frame Brackets with (4) 12mm Hex Bolts, (8) 12mm Flat Washers, (4) 12mm Lock Washers and (4) 12mm Hex Nuts, **(Figures 17 & 18)**. Do not tighten hardware at this time.
 11. Attach the Top Brackets to the Grille Guard with the included (2) 10mm Hex Bolts, (4) 10mm Flat Washers and (2) 10mm Nylon Lock Nuts, **(Figure 19)**. Check the Grille guard alignment with the vehicle. Adjust as required then fully tighten the Top and Frame Bracket to vehicle hardware only. Do not fully tighten the Grille Guard to Bracket hardware at this time.
 12. Reinstall the grille and top cover. **NOTE:** Loosen the hardware attaching the Grille Guard to the Brackets and tilt the Grille Guard forward to make room to reinstall the grille. **IMPORTANT:** Top Bracket to back of bumper hardware must be fully tightened before reinstalling the grille.
 13. Level and adjust the Grille Guard and fully tighten all hardware.
 14. On models with grille mounted front camera, remove the center panel from the Grille Guard, **(Figure 20)**.
 15. Do periodic inspections to the installation to make sure that all hardware is secure and tight.
- To protect your investment**, wax this product after installing. Regular waxing is recommended to add a protective layer over the finish. Do not use any type of polish or wax that may contain abrasives that could damage the finish.
- For stainless steel:** Aluminum polish may be used to polish small scratches and scuffs on the finish. Mild soap may be used also to clean the Grille Guard.
- For gloss black finishes:** Mild soap may be used to clean the Grille Guard.

Driver Side Mounting Bracket Installation Pictured

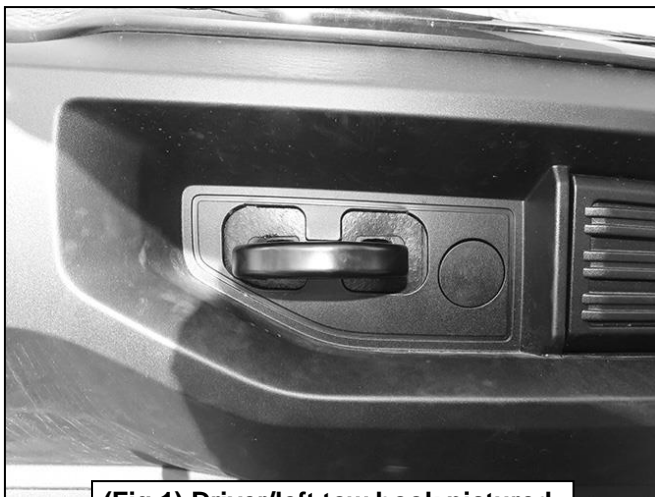

(Fig 1) Driver/left tow hook pictured

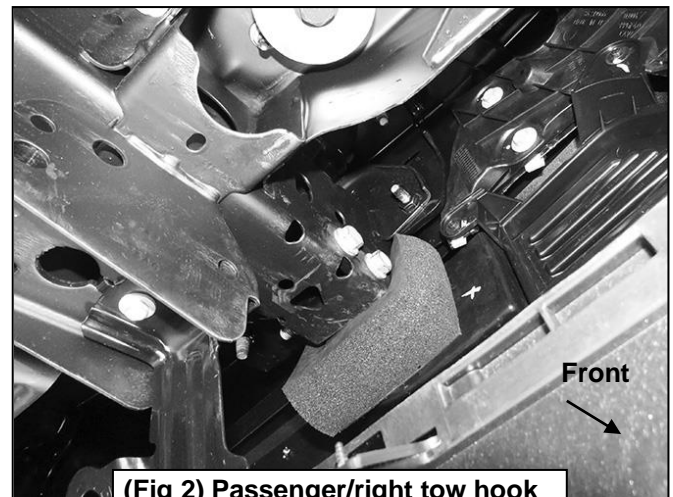

(Fig 2) Passenger/right tow hook pictured from behind bumper

Driver Side Mounting Bracket Installation Pictured



(Fig 3) Tow hook removed. Opening may need to be trimmed to clear the Mounting Bracket assembly

Area to cut out illustrated for example only

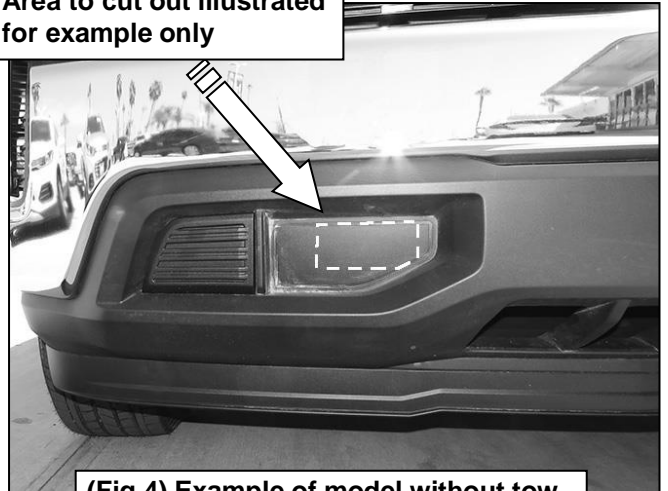

(Fig 4) Example of model without tow hooks, passenger/right side pictured

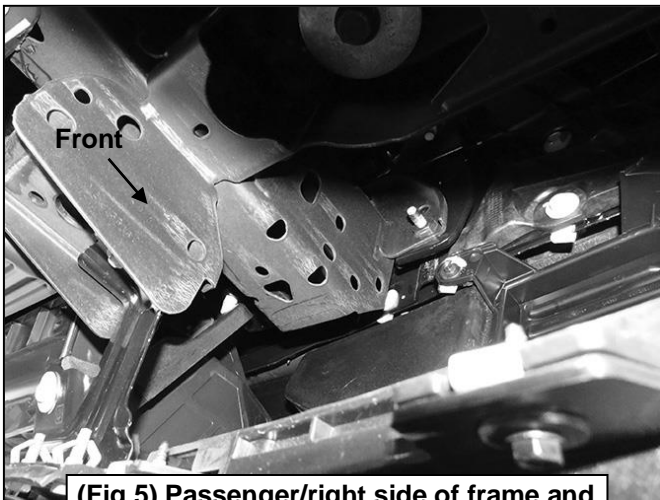

(Fig 5) Passenger/right side of frame and bumper pictured from behind bumper

- 12mm Bolt Plate
- 12mm Flat Washer
- 12mm Lock Washer
- 12mm Hex Nut

- 12mm Double Bolt Plate
- (2) 12mm Flat Washers
- (2) 12mm Lock Washers
- (2) 12mm Hex Nuts

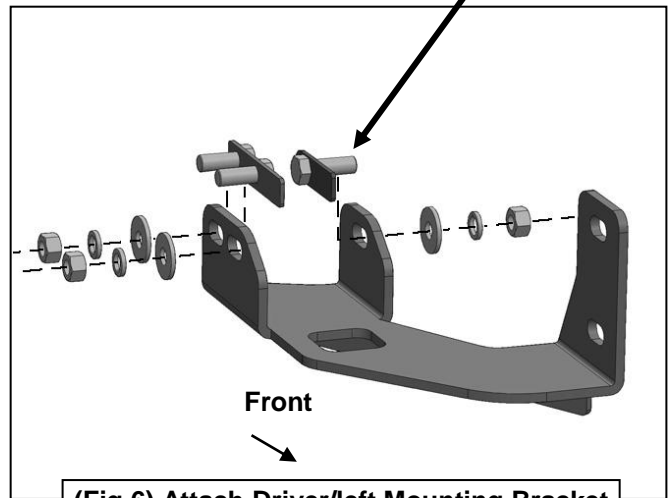

(Fig 6) Attach Driver/left Mounting Bracket to end of frame with Bolt Plates

Driver Side Mounting Bracket Installation Pictured

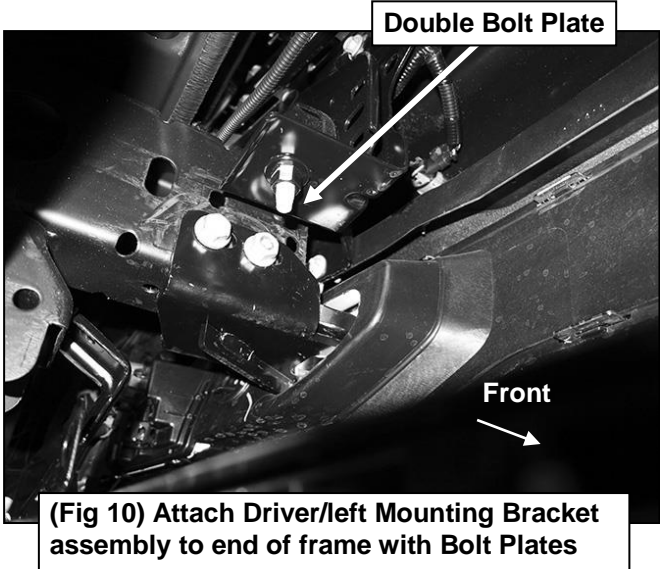
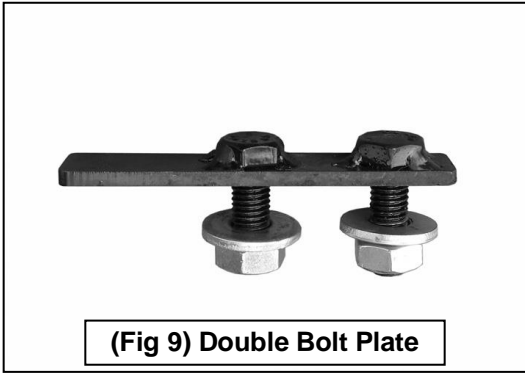
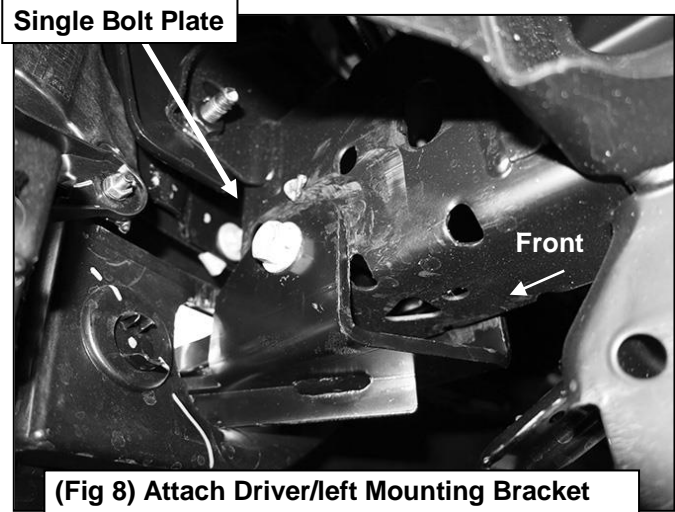
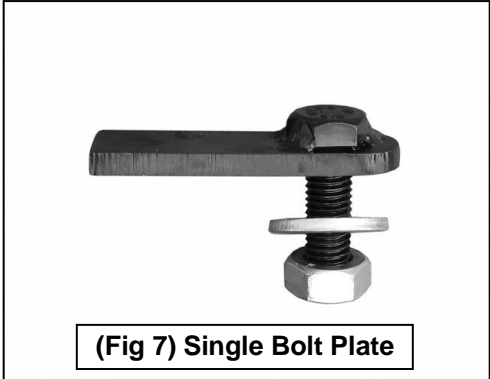

Driver Side Mounting Bracket Installation Pictured



(Fig 12) Remove screws attaching grille and carefully pull grille straight out to remove grille

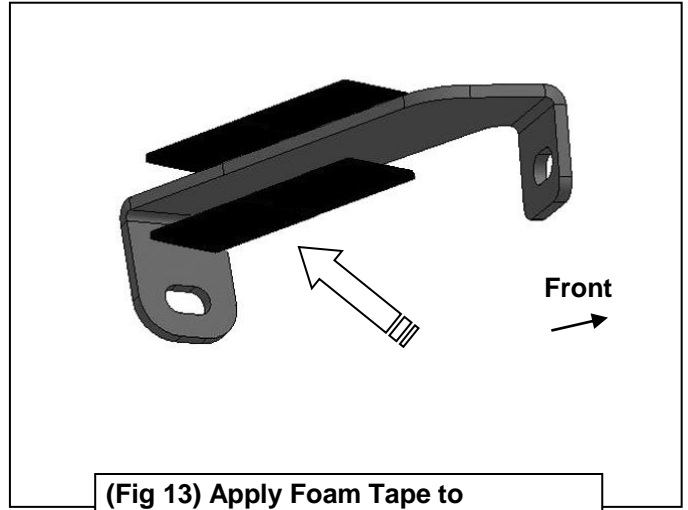

(Fig 13) Apply Foam Tape to underside of Driver/left Top Bracket

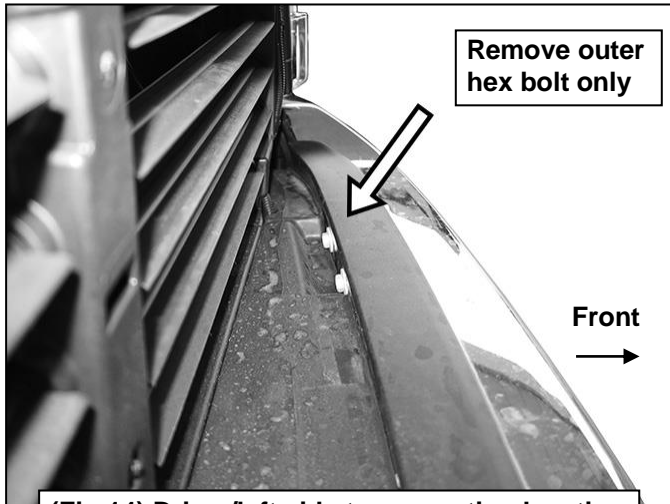

Remove outer hex bolt only

(Fig 14) Driver/left side top mounting location

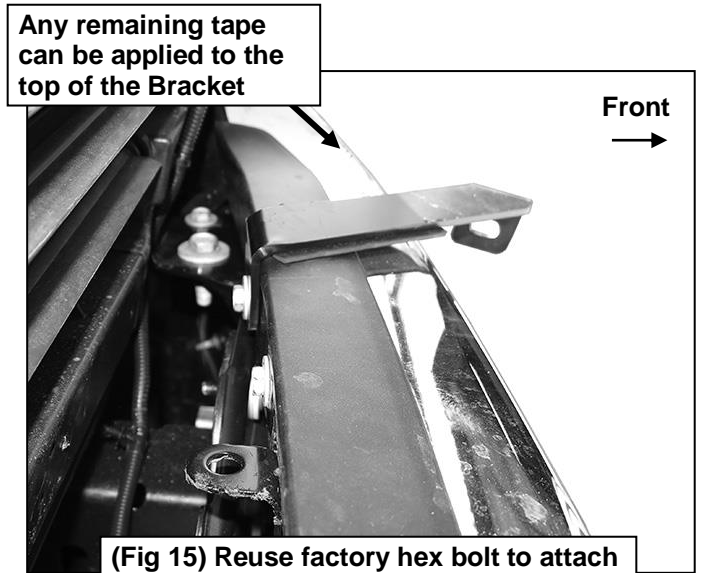

Any remaining tape can be applied to the top of the Bracket

(Fig 15) Reuse factory hex bolt to attach Top Bracket to back of bumper



(Fig 16) All Mounting Brackets installed

MODULAR RUGGED GRILLE GUARD

2019 SILVERADO 1500

EXCL. DIESEL MODELS WITH DEF TANKS & 2019 SILVERADO 1500 LD

Driver Side Mounting Bracket Installation Pictured

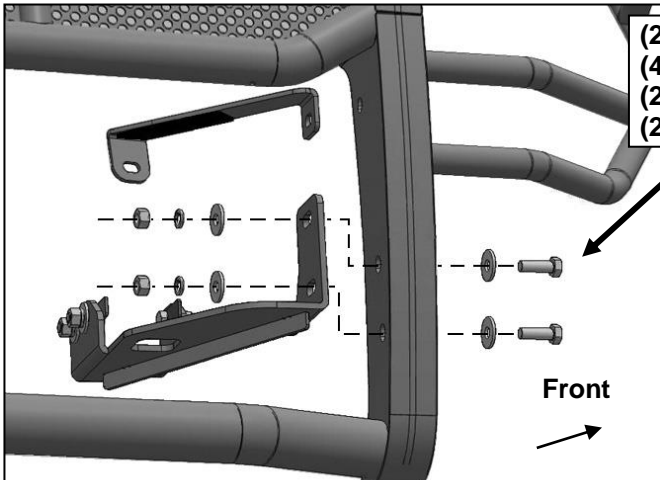

- (2) 12mm x 35mm Hex Bolts
- (4) 12mm Flat Washers
- (2) 12mm Lock Washers
- (2) 12mm Hex Nuts

Mounting holes for optional parking sensor relocation kit (available separately)

(Fig 17) Attach Grille Guard to Frame Brackets



(Fig 18) Grille Guard attached to driver/left Frame Bracket

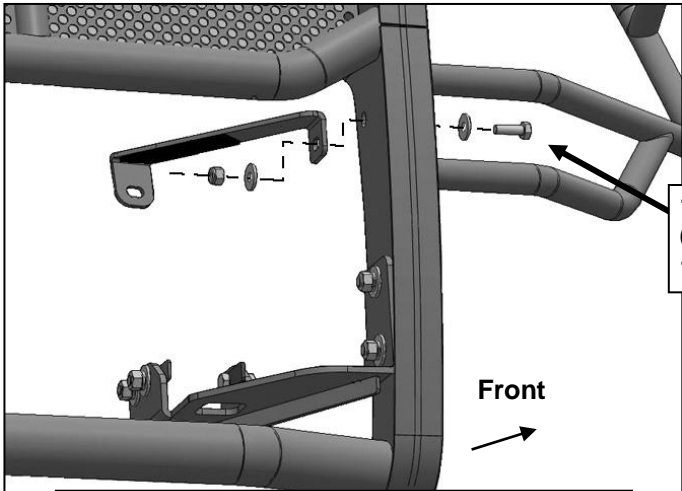

- 10mm x 30mm Hex Bolt
- (2) 10mm Flat Washers
- 10mm Nylon Lock Nut

(Fig 19) Attach Grille Guard to Top Bracket

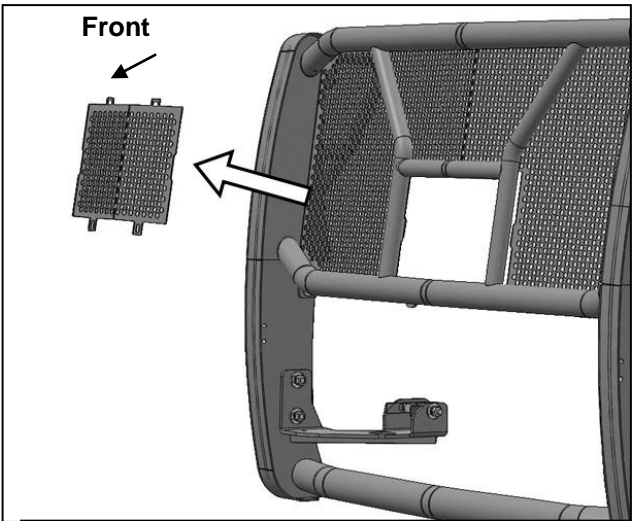

(Fig 20) On models equipped with grille mounted camera, remove center grille panel



Complete Installation