



PGBZA008SS-Installation Instructions

99-07 Mercedes G500/G55AMG W463 Stainless Steel Grille Guard

A. Installation

- 1 Place bumper bracket (1) with turned-in hinge bolt (3) on impact protection bar.
- 2 Place protection bar with bumper bracket on bumper and center it relative to the two outer edges of the fenders.

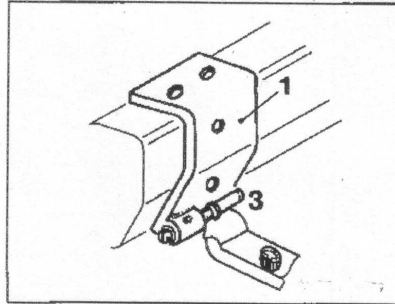

- 3 On the bumper, mark positions for two upper holes in bumper bracket.

Note: The bumper bracket must be in contact with the bumper across its entire contact surface.

- 4 Drill upper holes to a diameter of 13 mm (arrows).
- 5 Remove impact protection bar from brackets.

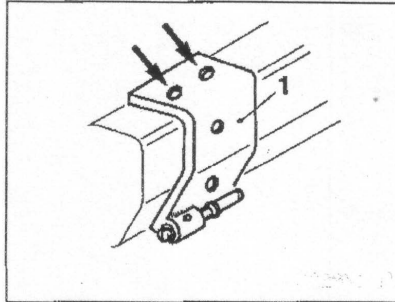

- 6 Bolt bumper bracket (1) with stop plate (4) and support (5) to bumper.

Note: Lightly tighten bolts.

- 7 Drill holes, dia. 10,5 mm, for countersunk screws (11). Attach bumper bracket at bottom with countersunk screws, washers and nuts.

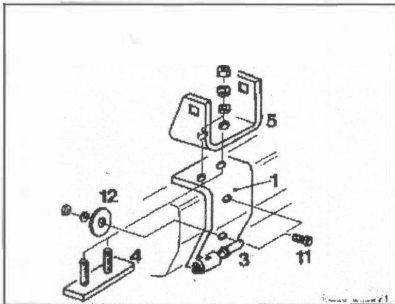

- 8 Fit stop joint (6) to support (5).

Note: Lightly tighten nuts.

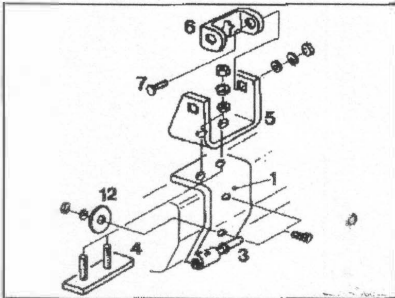

9 Screw quick-fastener into impact protection bar. Slide protection bar onto hinge bolt (5).

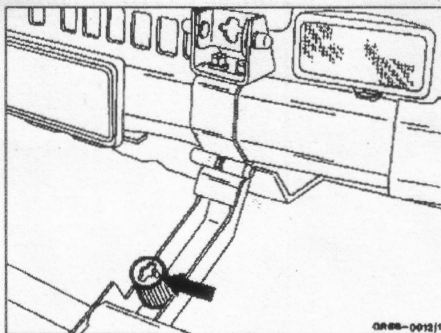

10 Adjust quick-fastener (8) to front end of vehicle by screwing in or out.

Note: Locking pin (detail X) must engage in cross-shaped cutout in stop joint (6). (Twist prevention).

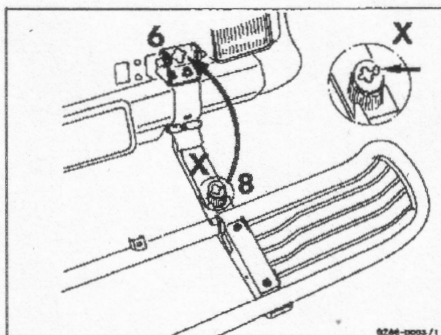

Note: Clearance between impact protection bar and front edge of vehicle should be 20 mm (arrows).

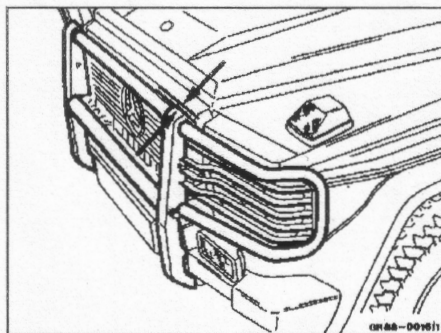

11 Align protection bar left and right by finely adjusting the hinge bolts (8).

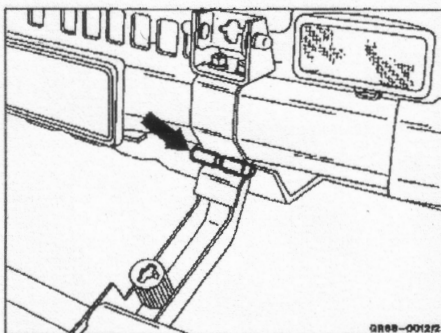

12 Remove impact protection bar.

13 Secure threads of hinge bolts (2) with adhesive (Loctite 241).

Note: Coat all holes with paint. Fully tighten all nuts and bolted connections.

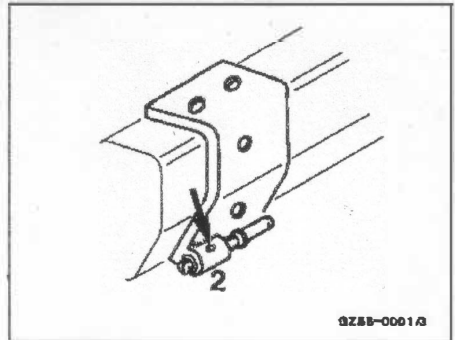

14 Fit impact protection bar. Secure hinge bolts with cotter pins (arrow).

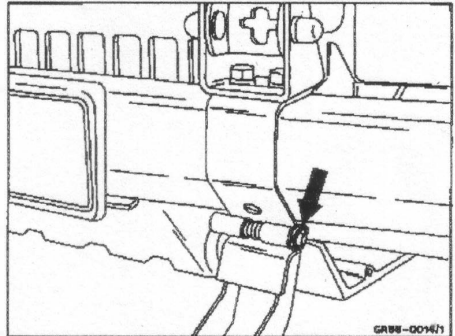

15 Insert quick-release bolts in stop joint.

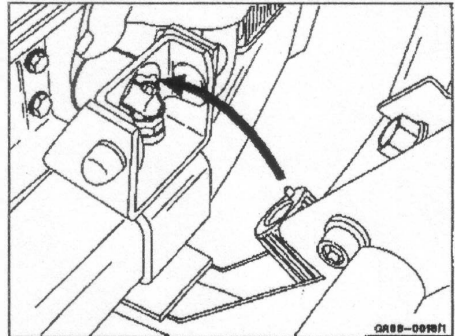

16 Tighten quick-release bolt with enclosed special wrench.

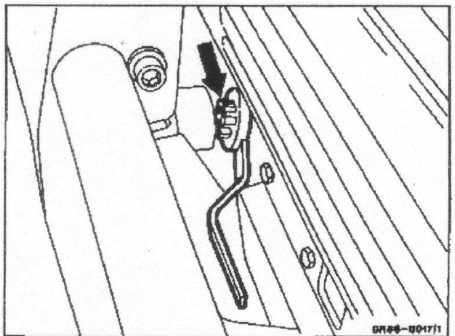

Name: Grille Guard
Item: BZ-A008

