

MAX T BULL BAR FOR 07-18 CHEVY SILVERADO/GMC SIERRA 1500(EXCLUDE 2007 CLASSIC MODELS)



INSTALLATION INSTRUCTIONS

**MAX T BULL BAR FOR 07-18 CHEVY SILVERADO/GMC SIERRA
1500(EXCLUDE 2007 CLASSIC MODELS)**

PART # MBT-MG203

Before Installation

- Please read the instruction completely for easy installation, which will also help you to avoid scratches or other potential damages to your appealing car.
- The figures here are for reference only and may have differences with the actual product you received, however they share the same assembly way.

Care and Cleaning

- Mild soap may be used also to clean the Product.
- Please periodically check and retighten all the hardware and clean the investment for a refresh look.

Parts list

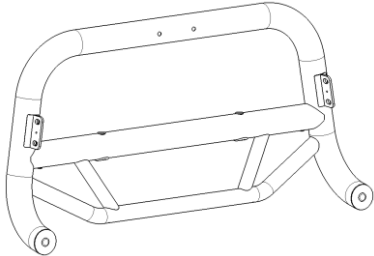
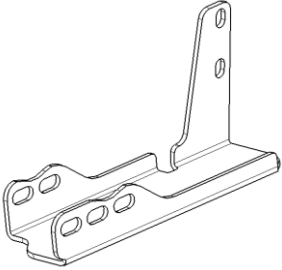
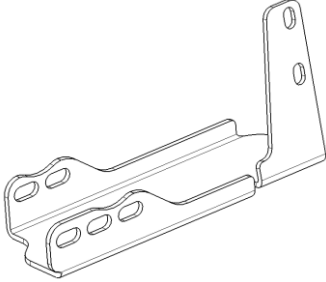
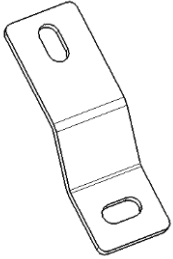
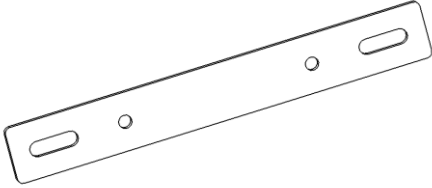
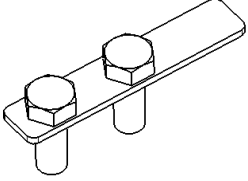
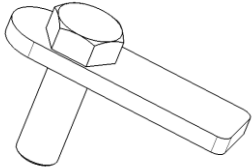
NO.	QTY	NAME	NO.	QTY	NAME
①	1	 Bull Bar	②	1	 Bracket L
③	1	 Bracket R	④	2	 License Plate Bracket 1
⑤	1	 License Plate Bracket 2	⑥	2	 Double Bolt Plate M12_27
⑦	2	 T Bolt M12_30			

MAX T BULL BAR FOR 07-18 CHEVY SILVERADO/GMC SIERRA 1500(EXCLUDE 2007 CLASSIC MODELS)

标准件清单

⑧	8	Flat Washer D10_27_3	⑨	4	Hex Bolt M10_30
⑩	4	Nylon Lock Nut M10	⑪	6	Nylon Lock Nut M12
⑫	6	Flat Washer D12 (12x24x2.5mm)	⑬	4	Flat Washer D6 (6x12x1.6mm)
⑭	4	Hex Nut M6	⑮	4	Assembly Bolt M6_20
⑯	2	Hex Button Head Bolt M6_20	⑰	2	Spring Washer D6
⑱	1	Allen Wrench S=4			

Installation Steps

Installation Figure:

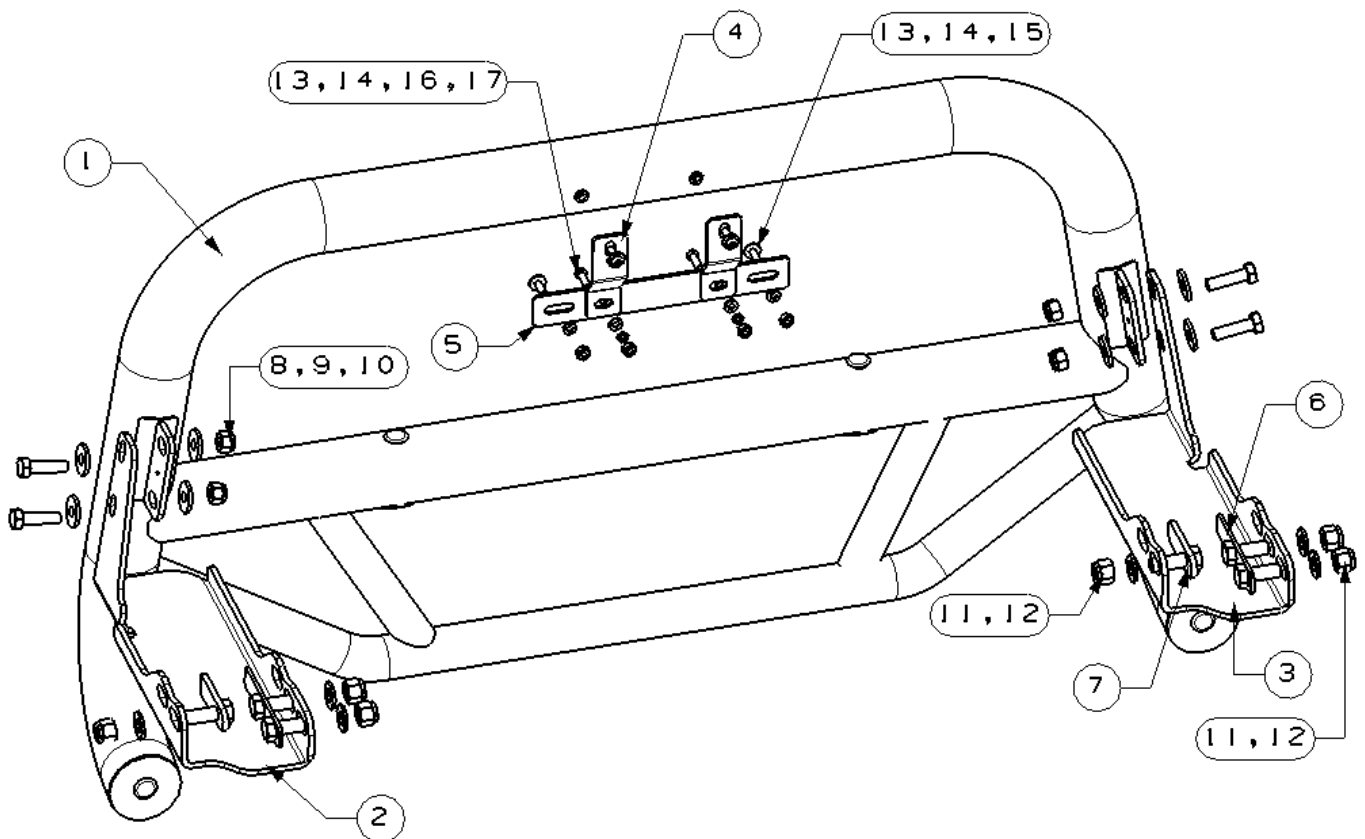

STEP 1:

Start installation from under the front of the vehicle. Determine if the vehicle is equipped with tow hooks.

IMPORTANT: Tow hooks cannot be reinstalled with the Guard.

Tow Hook equipped vehicles:

Remove the factory tow hook from the end of each frame channel, (Fig 1). Skip to Step 2 if tow hooks were accessible and have been removed. NOTE: Tow hooks on 2014-on models may be difficult to remove and assistance is highly recommended on these models. The following info only applies to the 2014-on models.

- a. On models with factory fog lights, unplug both lights. Move all wiring harnesses away from bumper.
- b. Open the hood and remove the cover between the top of the radiator and the grille. Remove the bolts attaching the bottom of the grille if attached to the cross member. Remove the grille.
- c. On 2014-15 models, from behind the bumper, release the clips and hardware to remove the plastic body panel, (facia), on top of the bumper between the bottom of the grille and the top of the bumper, (Fig 2).
- d. Remove the outer bumper supports on each side of the frame.
- e. Place blocks or jack stands under the front bumper to support it during mounting bolt removal. Once the bumper has been safely supported, remove the factory bumper bolts attaching the bumper to the inner bumper bracket bolted to the end of the frame, (Figs 2-3).

WARNING! Assistance is required to hold the bumper in place during bolt removal to prevent the bumper from falling. Carefully slide the bumper assembly with brackets off of the ends of the frame.

- f. Once bumper has been removed, remove both tow hooks.
- g. Reattach the bumper, facia panel if equipped and grille after both tow hooks have been removed and the openings have been checked for Bracket clearance. Trim around openings as required for Bracket clearance.
- h. Tighten all factory bumper hardware at this time.
- i. Proceed to Step 2.

2014-15 models, from behind the bumper, remove the clips securing the fascia to the top of the bumper



(Fig 1) Example of Tow hook

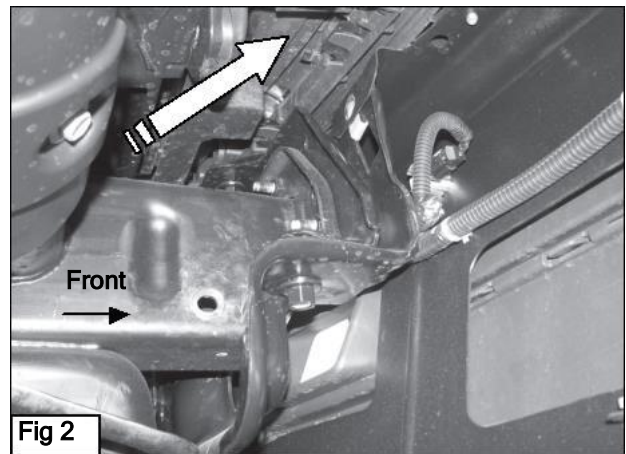
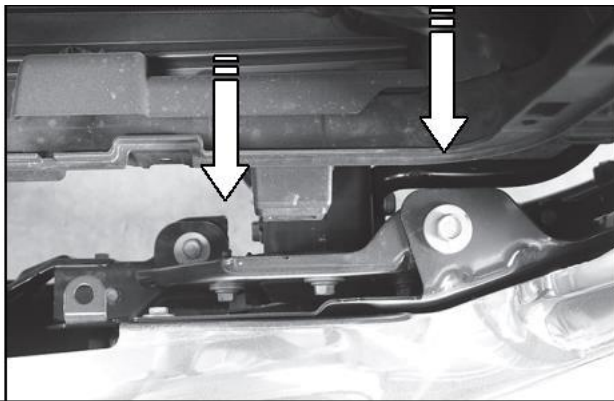

Fig 2



(Fig 3) 2016 model to show bumper bolt locations from above (arrows) with grille removed. 2014-15 models also remove plastic fascia panel to access bumper bolts as necessary

Vehicles without Tow Hooks:

a. Cut out the indented area on both sides of the plastic bumper insert to clear the Brackets as pictured, (Figs 4-5).

IMPORTANT: Make several small cuts for best fit. Do not cut through the top edge of the panel.

NOTE: On 2014-15 models, the plastic panel is held in place with several small screws. The screws at the top corners are difficult to impossible to reach and remove without damaging the cover with the bumper in place. If you prefer to remove the panel to cut out the openings, it will be easier to remove the bumper assembly with the plastic panel attached.

b. Reattach the bumper assembly, (if removed), fascia and grille once openings have been cut out and checked for clearance. Tighten all factory bumper hardware at this time.

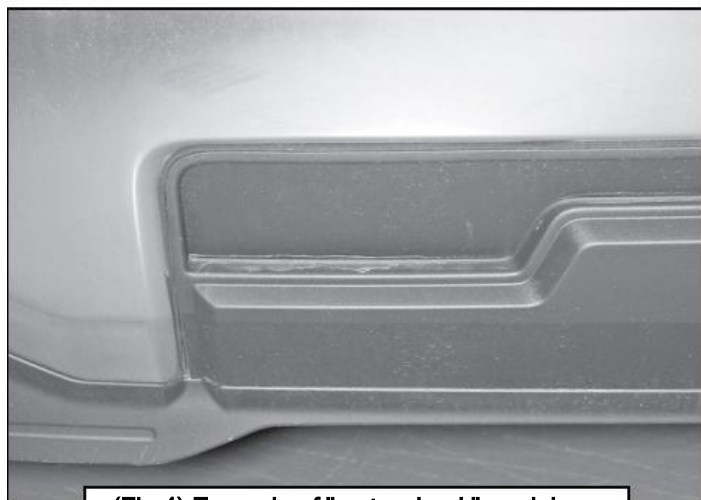

(Fig 4) Example of "no tow hook" model

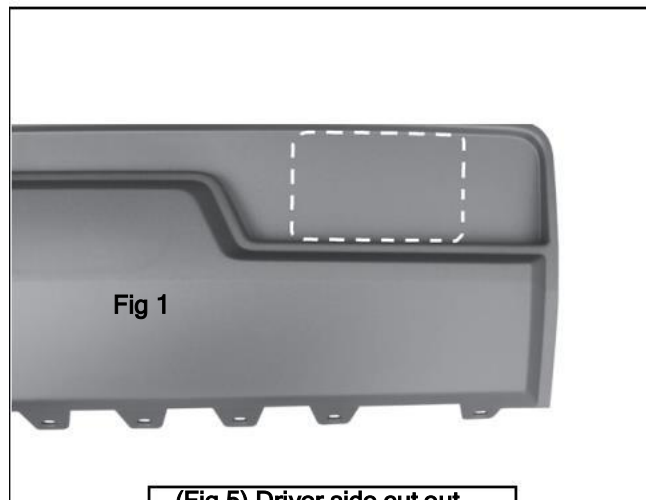

(Fig 5) Driver side cut out illustrated for reference only

STEP 2:

Select the driver side Mounting Bracket. Insert the Bracket through the opening in the bumper, (Fig 5). Trim the plastic as required to clear the Brackets.

STEP 3:

Line up the holes in the Bracket with the holes in the end of the frame channel for the tow hook, (Fig 6). Select (1) 12mm Double Bolt Plate, (Fig 7). Insert the Bolt Plate into the end of the frame, through the (2) holes in the side of the frame and out through the Bracket, (Figs 8-9). Secure the Bracket to the Bolt Plate with (2) 12mm Flat Washers and (2) 12mm Nylon Lock Nuts. Snug but do not fully tighten hardware at this time.

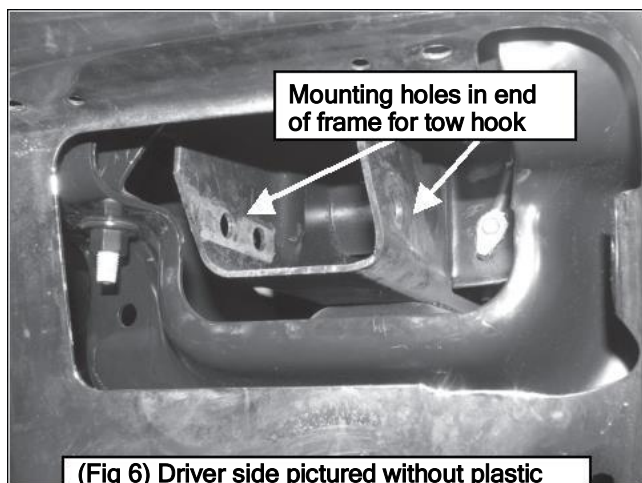

(Fig 6) Driver side pictured without plastic panel for instruction purposes only



Fig 7

STEP 4:

Repeat Step 3 to install the 12mm Single Bolt Plate, (Fig 10), into the remaining hole in the other side of the frame channel and Bracket, (Figs 8 & 11).

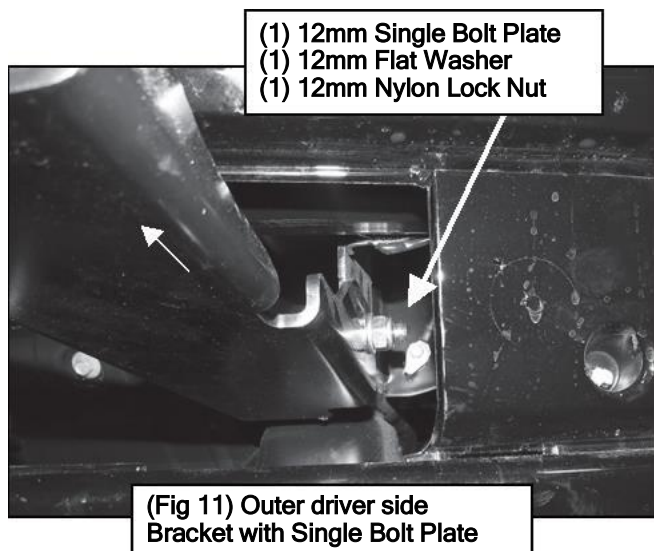
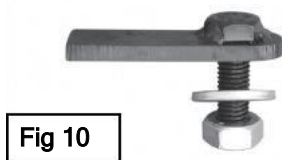
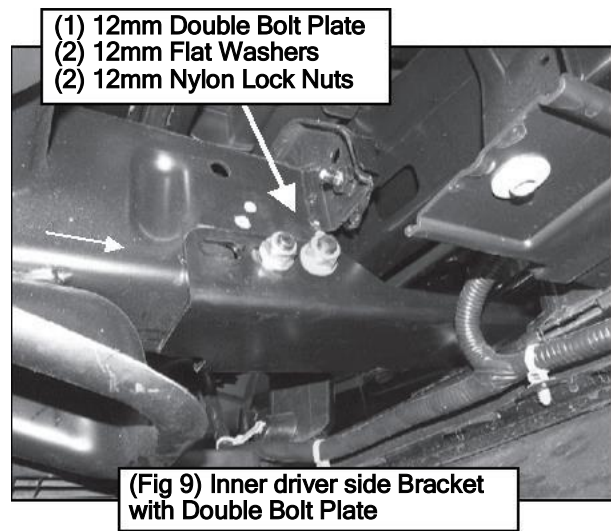
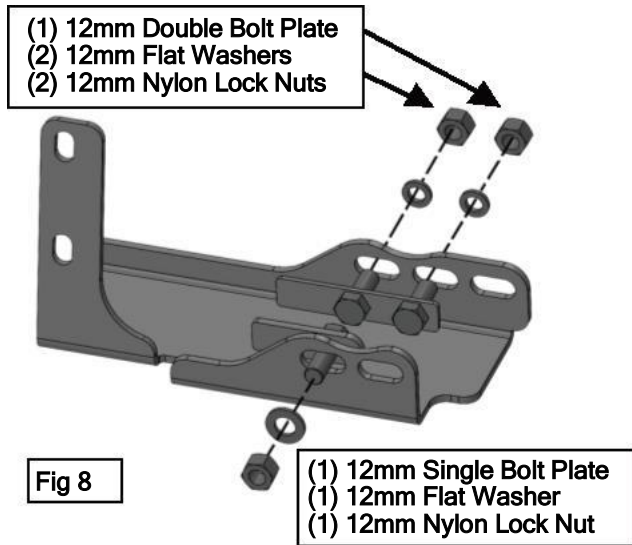

STEP 5:

IMPORTANT:

The Brackets are designed with (2) mounting positions to fit multiple years. Most Silverado/Sierra models will use the “back” mounting position with the Brackets pushed in to install the Guard closer to the bumper, (Fig 8). Some years may require the forward mounting position to move the Guard forward or to provide more clearance for accessory lights, (Fig 12).

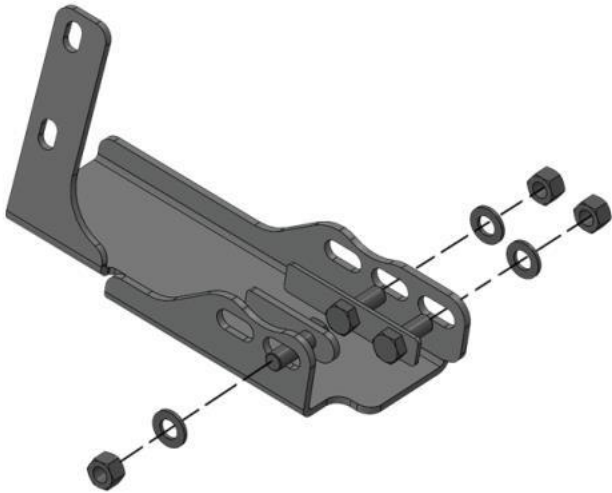

(Fig 12) Forward mounting position

STEP 6:

Repeat Steps 2-5 to install the passenger side Mounting Bracket.

STEP 7:

With assistance, hold the Guard up in position on the outside of the Mounting Brackets. Bolt the Guard to the Brackets with (4) 10mm Hex Bolts, (8) 10mm Flat Washers and (4) 10mm Nylon Lock Nuts, (Figs 13-14). Do not tighten hardware at this time.

- (2) 10mm Hex Bolts
- (4) 10mm Flat Washers
- (2) 10mm Nylon Lock Nuts

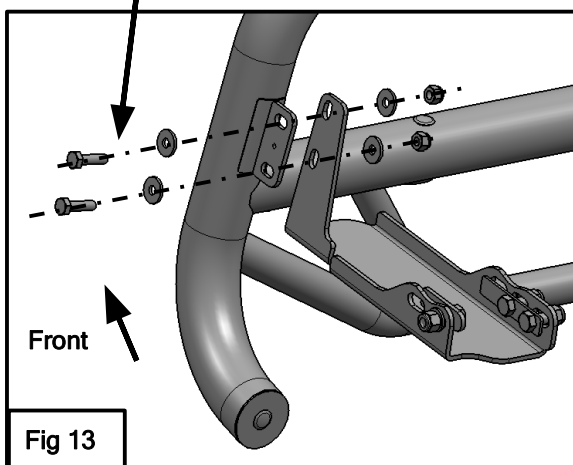
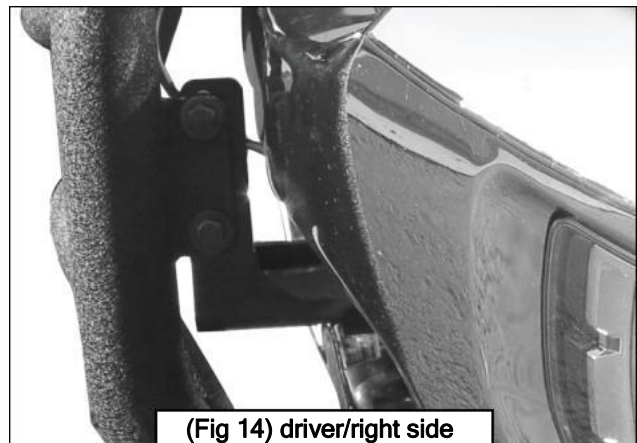

Fig 13



(Fig 14) driver/right side complete installation

STEP 8:

Install License Plate Bracket.

- a. Connect License Plate Bracket 1 on bull bar with (2) Assembly Bolts M6_20.
- b. Connect License Plate Bracket 1 and License Plate Bracket 2 with (2) Hex Button Head Bolts M6_20, (2) Flat Washers D6, (2) Spring Washers D6, (2) Hex Nuts M6.
- c. Install license plate to License Plate Bracket 2 with (2) Assembly Bolts M6_20, (2) Flat Washers D6, (2) Hex nuts M6.

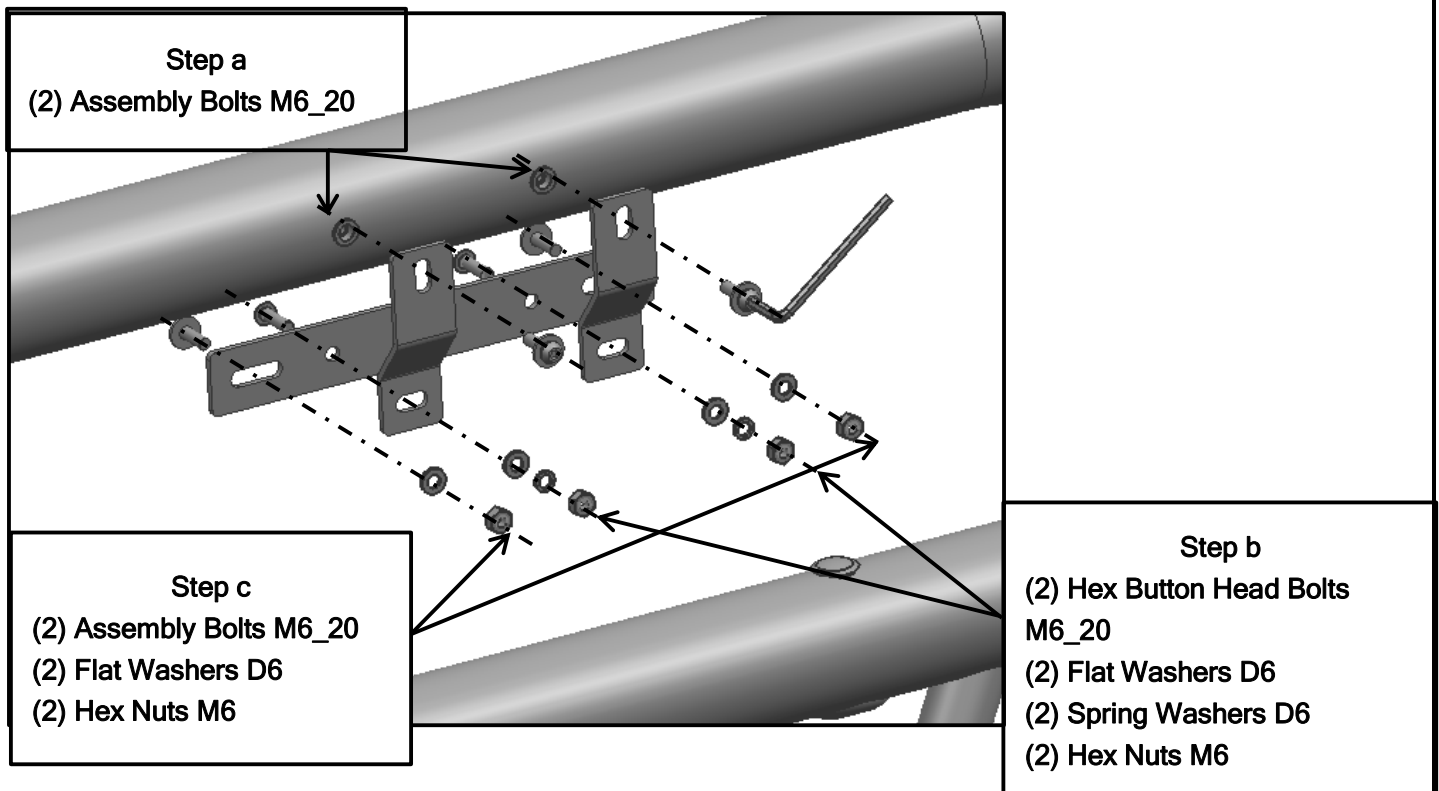

STEP 9:

Check the Guard alignment with the vehicle and for clearance between the Guard and the bumper. If Guard is too close to or touching bumper, remove the Guard and reinstall the Brackets in the “forward” position away from the bumper (Fig 12). Adjust as required then fully tighten all hardware at this time.

STEP 10:

Do periodic inspections of the installation to make sure that all hardware is secure and tight.

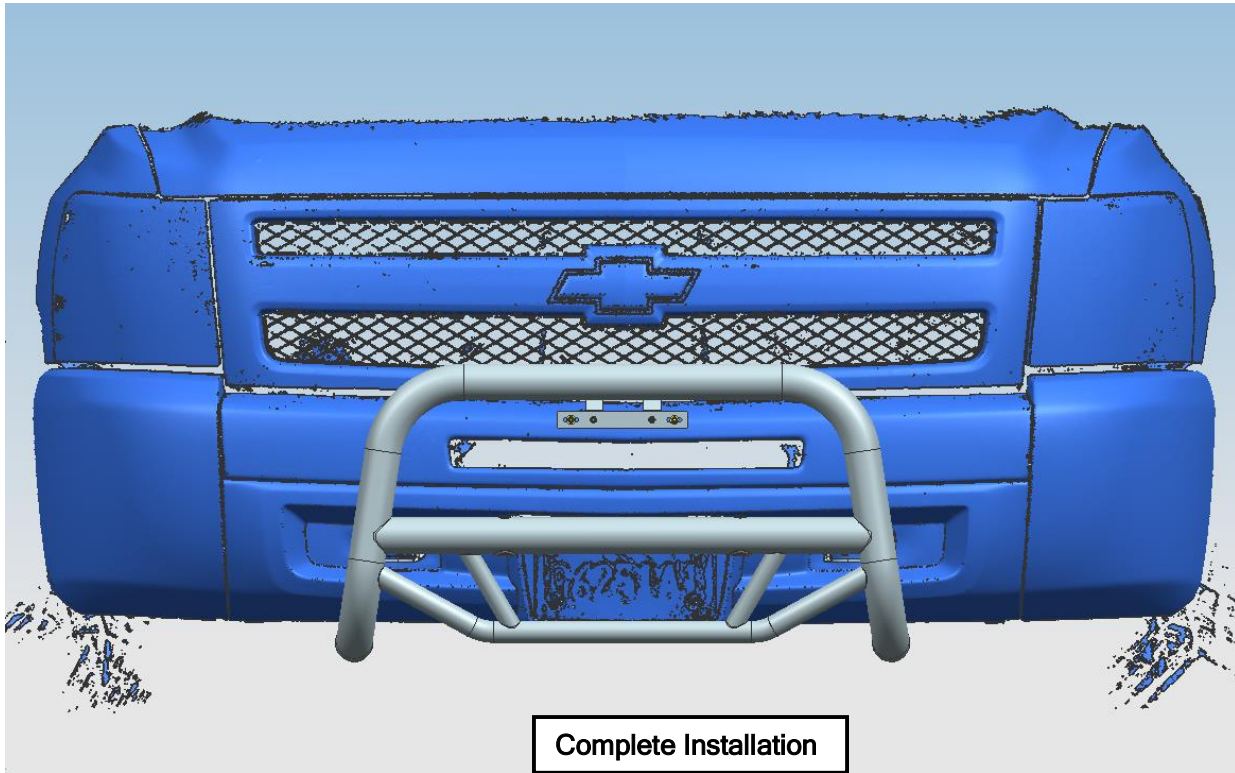

Complete Installation

NOTE

Any damages and losses caused by improper installation and application, goes beyond our quality warranty.