

INSTALLATION INSTRUCTIONS

ARMOUR REAR BUMPER
2007-17 CHEVY SILVERADO 1500

ARMOUR REAR BUMPER
2007-17 CHEVY SILVERADO 1500
PART#ARB-SI16

PARTS LIST:

1	ARMOUR Rear Bumper Assembly	4	12-1.75mm x 35mm Hex Bolts
1	Driver/left Frame Bracket	8	12mm x 37mm OD x 3mm Flat Washers
1	Passenger/right Frame Bracket	4	12mm Nylon Lock Nuts
1	License Plate Light	2	10-1.5mm x 50mm Hex Bolts
2	License Plate Plugs	4	10mm x 34mm OD x 3mm Flat Washers
4	Sensor Hole Plugs	2	10mm Nylon Lock Nuts
1	Trailer Plug Bracket 07-13	2	6mm x 16mm Hex Bolts
1	Trailer Plug Bracket 2014+	4	6mm ID x 12mm OD x 1.6mm Flat Washers
10	Nylon Wire Ties	2	6mm Nylon Lock Nut
6	14-2.0mm x 45mm Hex Bolts	1	4mm Allen Wrench
12	14mm x 28mm OD x 2.5mm Flat Washers	8	4mm x 10mm Button Head Bolts
6	14mm Nylon Lock Nuts		

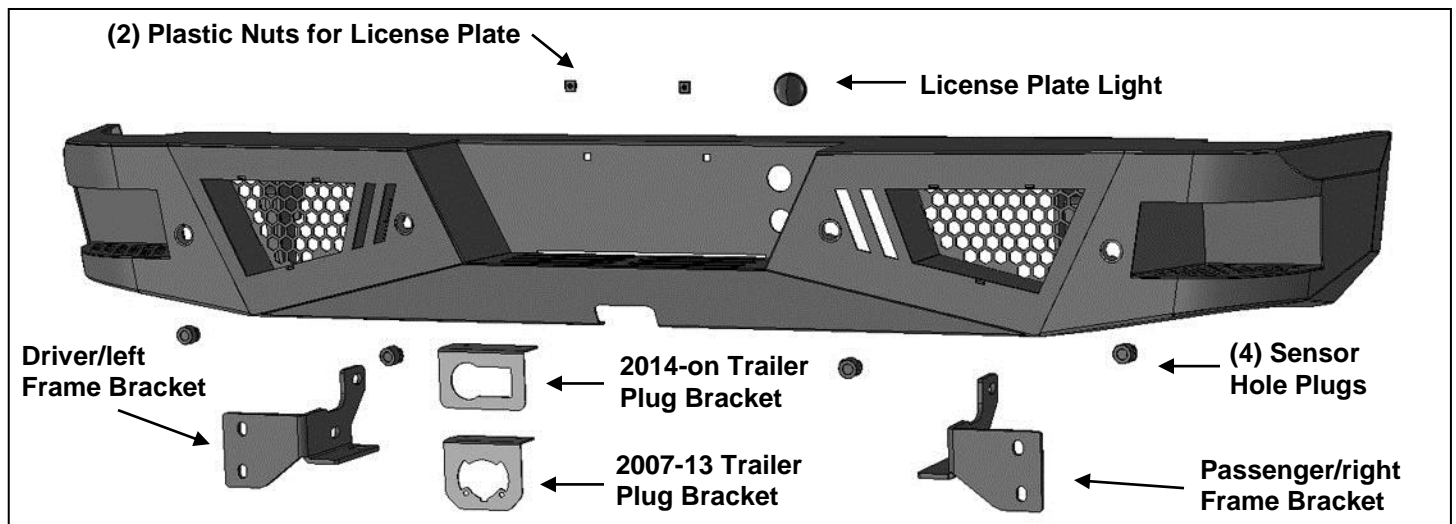

PROCEDURE:

REMOVE CONTENTS FROM BOX. VERIFY ALL PARTS ARE PRESENT. READ INSTRUCTIONS CAREFULLY BEFORE STARTING INSTALLATION. BUMPER IS HEAVY, ASSISTANCE IS HIGHLY RECOMMENDED TO AVOID POSSIBLE INJURY OR DAMAGE TO THE VEHICLE.

1. Remove the license plate. On models with bumper sensors, unplug all sensors. Remove the trailer plug from the bumper. Release the wiring harness from the clips attached to the back of the bumper and move harness away from bumper as necessary.
2. Place blocks or jack stands under the bumper to support it during mounting bolt removal.
3. Determine procedure for your model year:

07-13 Models.

- a. Starting on the passenger/right side, remove (2) hex bolts attaching bumper to top/center of receiver hitch if equipped.
- b. Remove hex bolts from side and bottom of frame, **(Figures 1—3)**.
- c. Repeat previous Steps to remove driver/left side hardware.
- d. With assistance, pull bumper and brackets straight out from vehicle, **(Figures 6 & 7)**.

14-16 Models.

- a. Starting on the passenger/right side, remove rear bolts attaching bed to frame, **(Figure 2)**. Loosen center bolts (if equipped). Do not loosen front bolts.
- b. Remove hex bolts from side and bottom of frame, **(Figures 1—3)**.
- c. Repeat previous Steps to remove driver/left side hardware.
- d. Raise bed up slightly, only enough to clear bumper brackets. With assistance, pull bumper and brackets straight out from vehicle, **(Figures 6 & 7)**.

OPTION, 14-16 models only, bumper must be disassembled to remove to avoid raising the bed. Release the clips attaching the plastic cover to the steel bumper, **(Figure 4)**. Remove cover and hardware attaching the outer bumper to the bumper brackets, **(Figure 5)**. With assistance, remove the outer steel bumper, from the brackets, then remove the hex bolts attaching the brackets to the frame. Slide the brackets out of the ends of the frame, **(Figures 6 & 7)**.

4. Select the passenger/right Frame Bracket, **(Figure 8)**. Slide the Bracket into the end of the frame. Attach the Bracket to the forward hole in the frame with (1) 10mm x 50mm Hex Bolt, (2) 10mm Flat Washers and (1) 10mm Nylon Lock Nut. Attach the Bracket to the side and bottom of the frame with (2) 14mm x 45mm Hex Bolts, (4) 14mm Flat Washers and (2) 14mm Nylon Lock Nut, **(Figures 8 & 9)**. Do not fully tighten hardware at this time. **NOTE:** On some models/years, the factory tow hitch may have support straps attached to the outside of the frame. Use the included (1) 14mm x 45mm Hex Bolt, (2) 14mm Flat Washers and (1) 14mm Nylon Lock Nut to attach the top hole in the strap to the top mounting hole, **(Figures 7 & 10)**. Bottom hole in strap is attached to Bumper Bracket.
5. Repeat **Step 4** to install the driver/left Frame Bracket.
6. Temporarily support the weight of the Bumper. **WARNING:** To avoid possible injury or damage to the vehicle, do not proceed until the Bumper is fully and safely supported.
7. With assistance, position the Bumper Assembly up to the Frame Brackets. Attach the Bumper to the Brackets with the included (4) 12mm x 35mm Hex Bolts, (8) 12mm Flat Washers and (4) 12mm Nylon Lock Nuts, **(Figures 11 & 12)**. Do not fully tighten hardware at this time.
8. Level and adjust the bumper and fully tighten all hardware. Slowly open tailgate and check for clearance. Adjust as necessary.
 - a. **2014-16 models only**, reinstall and tighten bed attachment bolts if loosened, (see **Step 3**).
9. Use the included (2) push-in Plastic Nuts to attach the rear license plate to the (2) holes in the Bumper, **(Figure 13)**. Insert the License Plate Light into the hole in the bumper, **(Figure 13)**. Attach the License Plate Light wire to the end of the factory license plate light wire harness.
10. Select the correct mounting plate for your trailer harness plug. Attach the mounting plate to the bottom of the bumper with (2) 6mm Hex Bolts, (4) 6mm Flat Washers and (2) 6mm Nylon Lock Nuts, **(Figure 13)**. **NOTE:** On 2011-14 models, use the included (2) Self Tapping Screws to attach the trailer plug to the Bracket, **(Figure 13)**.
11. **LED light installation at ends of bumper** as supplied with bumper or sold separately.
 - a. Insert light into opening and up to mounting slots. Check for clearance between front and back of light. If necessary, remove the screen from the back of the opening for additional clearance or access to light, **(Figure 14)**.
 - b. Follow the light manufacturer's instructions to attach (1) light to the center slot or (2) lights to the inner and outer slots in the top of the light opening.
 - c. Repeat the above steps for passenger side light installation.
 - d. Follow light manufacturer's instructions to properly wire the light.
12. **Models with bumper mounted sensors:**
 - a. Remove the rubber plugs from the sockets in the bumper assembly. Push the sensor in from the back of the bumper. Secure each sensor to the socket with (2) 4mm x 10mm Button Head Screws, **(Figure 15)**. **IMPORTANT:** Sensors fit snug in sockets. The 4mm Screws are used to apply slight pressure to lock the sensors in place. Tighten both screws evenly until they touch the sensor body only. Do not overtighten screws or damage to sensors will result.
 - b. Reattach the factory wiring harness to sensors.
13. Attach the wiring harness to the lights and trailer plug.
14. Use the included Wire Ties to secure the wiring harness to the bumper and frame as necessary.
15. Do periodic inspections to the installation to make sure that all hardware is secure and tight.

To protect your investment, wax this product after installing. Regular waxing is recommended to add a protective layer over the finish. Do not use any type of polish or wax that may contain abrasives that could damage the finish. Mild soap may be used to clean the Bumper assembly.

Passenger/right side installation pictured

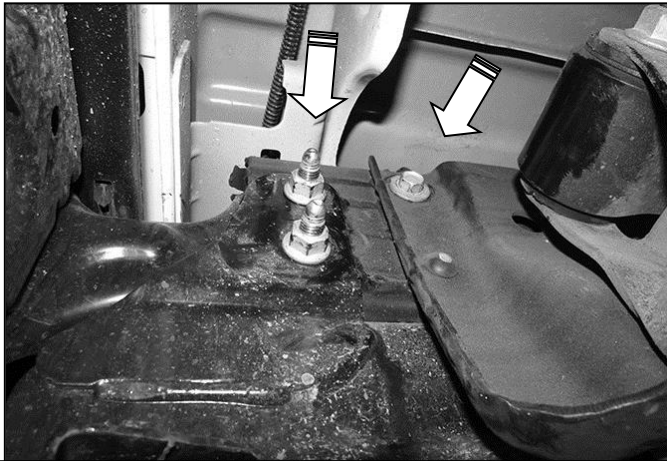

(Fig 1) Remove bumper bolts from outside of frame (arrows). Passenger side pictured from below

WARNING! Before removing hardware, fully support the weight of the bumper with blocks or stands to prevent injury or damage to the vehicle.

2014-16 models, remove rear bed to frame bolts, loosen center bolts, (if equipped). Do not loosen front bolts.



(Fig 2) Remove bumper bolt from bottom of frame (arrow). Back of passenger side of model w-o receiver hitch pictured from below



(Fig 3) Remove bumper bolts attaching brackets to frame (arrows). Model with receiver hitch pictured from below

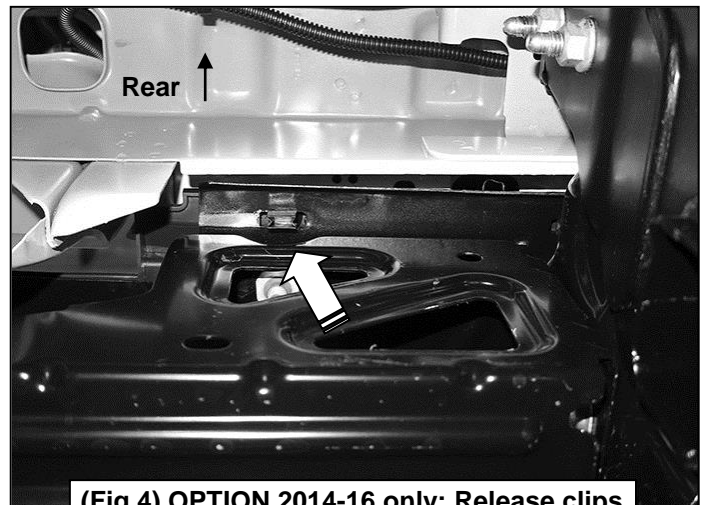

(Fig 4) OPTION 2014-16 only: Release clips to remove plastic bumper cover (arrow). Passenger side pictured from below

Passenger/right side installation pictured



(Fig 5) OPTION 2014-16 only: Remove bumper bolts attaching bumper to inner bracket. Remove outer bumper first, then remove inner brackets

WARNING! Before removing hardware, fully support the weight of the bumper with blocks or stands to prevent injury or damage to the vehicle.

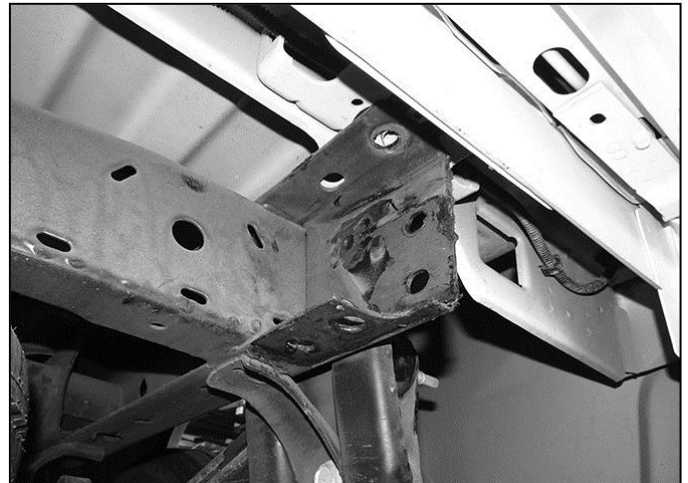

(Fig 6) End of frame once factory bumper is removed. Passenger side w-o receiver hitch pictured



(Fig 7) End of frame once factory bumper is removed. Passenger side with receiver hitch pictured

14mm x 45mm Hex Bolt
(2) 14mm Flat Washers
14mm Nylon Lock Nut

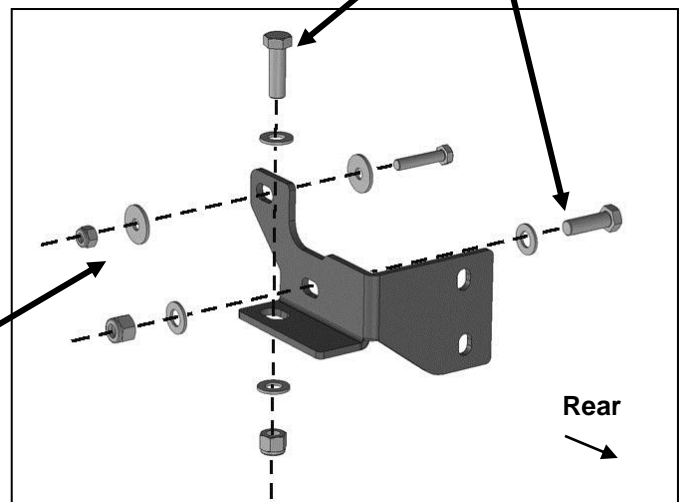

10mm x 50mm Hex Bolt
(2) 10mm Flat Washers
10mm Nylon Lock Nut

(Fig 8) Attach Bumper Bracket to side mounting holes in frame and hitch if equipped

Passenger/right side installation pictured

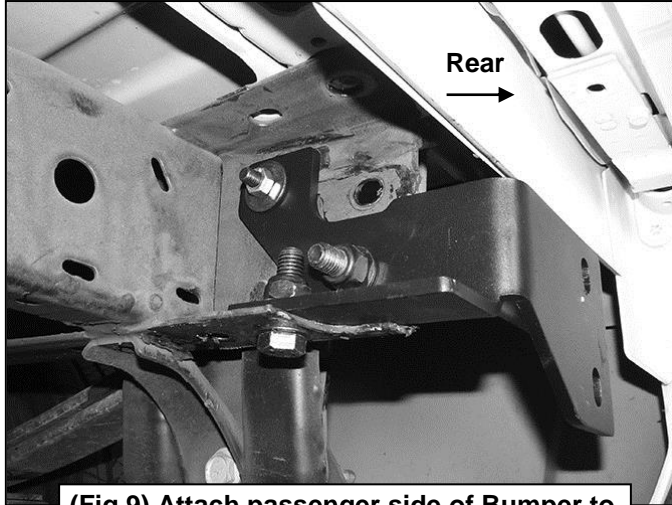

(Fig 9) Attach passenger side of Bumper to frame. Model w-o receiver hitch pictured

- (2) 12mm x 55mm Hex Bolts
- (4) 12mm Flat Washers
- (2) 12mm Nylon Lock Nuts

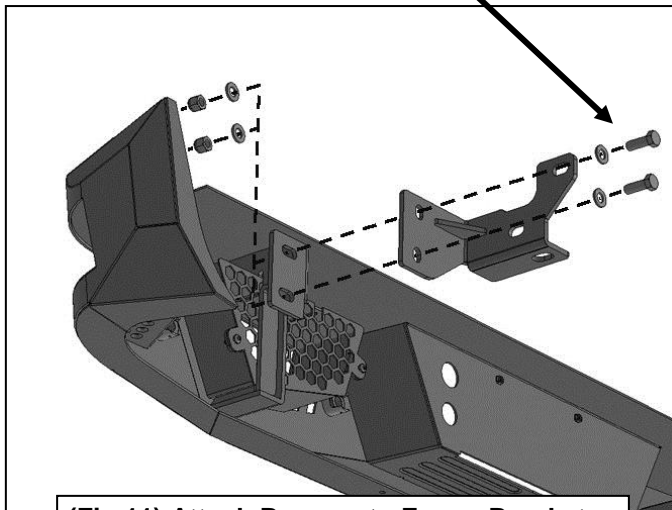

(Fig 11) Attach Bumper to Frame Brackets

WARNING! Before installation, fully support the weight of the bumper with blocks or stands to prevent injury or damage to the vehicle.

- 14mm x 45mm Hex Bolt
- (2) 14mm Flat Washers
- 14mm Nylon Lock Nut

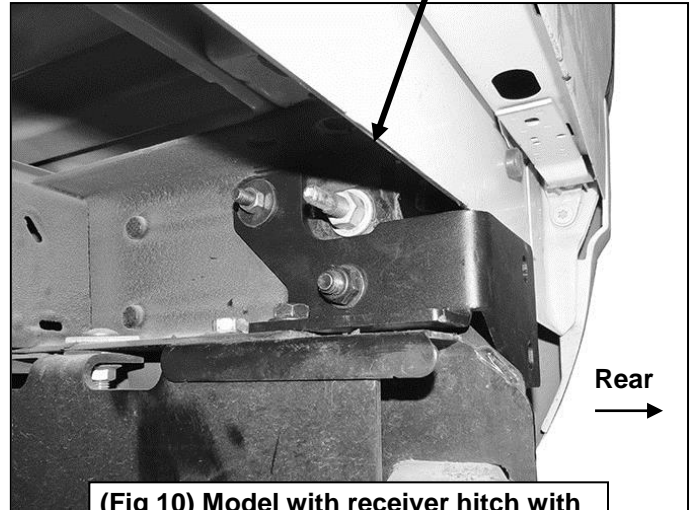

(Fig 10) Model with receiver hitch with support strap pictured (also see Fig 7)



(Fig 12) Attach Bumper to Frame Brackets

(2) License plate mounting nuts (plugs)

License plate light

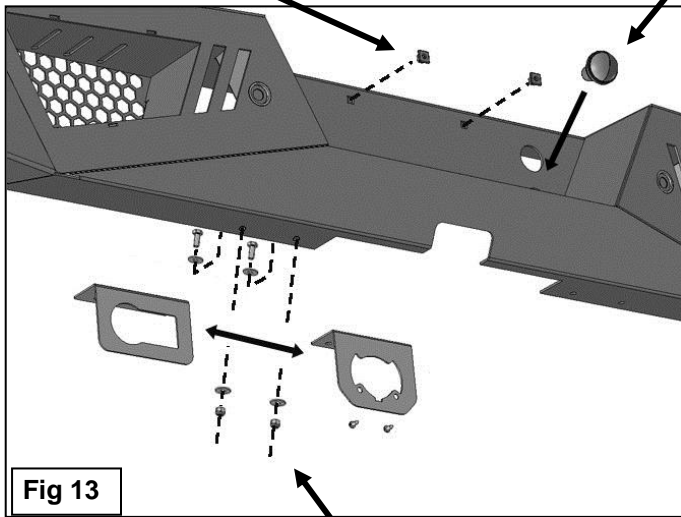

(2) 6mm Screws
(4) 6mm Flat Washers
(2) 6mm Nylon Lock Nuts

Remove screens if necessary for additional clearance around or access to lights

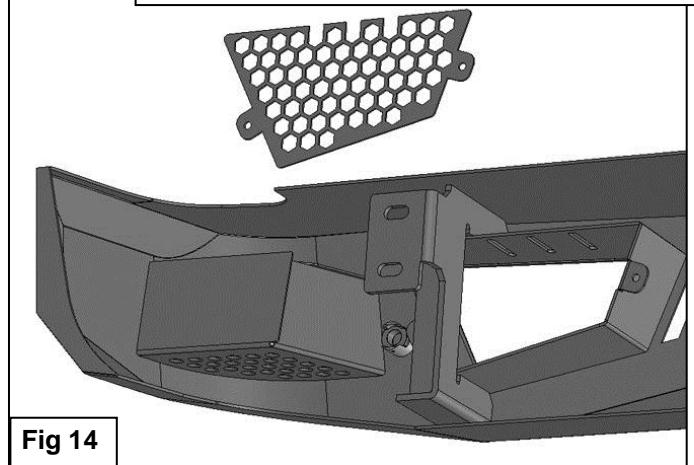

Remove Plugs

(2) 4mm Screws

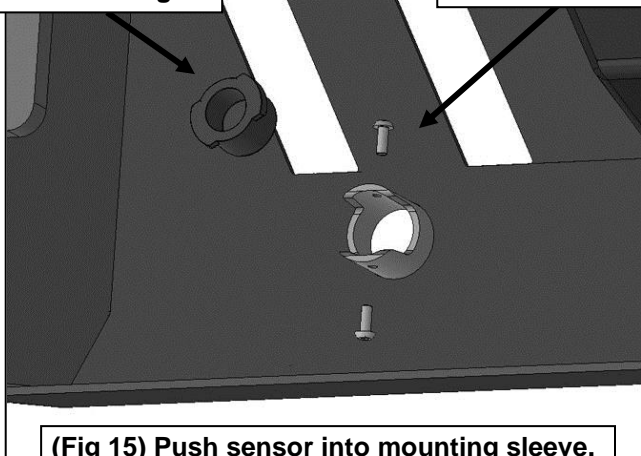

IMPORTANT: Sensors fit snug in sockets. The 4mm Screws are only used to apply slight pressure to lock the sensors in place. Tighten both screws evenly until they touch the sensor body only. Do not overtighten screws or damage to sensors will result.

