

INSTALLATION INSTRUCTIONS

ARMOUR REAR BUMPER
1999-16 FORD SUPER DUTY F250-350

ARMOUR REAR BUMPER FOR
99-16 FORD F250/350 SUPERDUTY
PART#ARB-F209

PARTS LIST:

1	ARMOUR Rear Bumper Assembly	2	Plastic Plugs for license plate mount
2	2-hole Spacer Plates (for tow hitch only)	8	4mm x 10mm Socket Head Screws
4	Sensor Plugs	1	Wrench

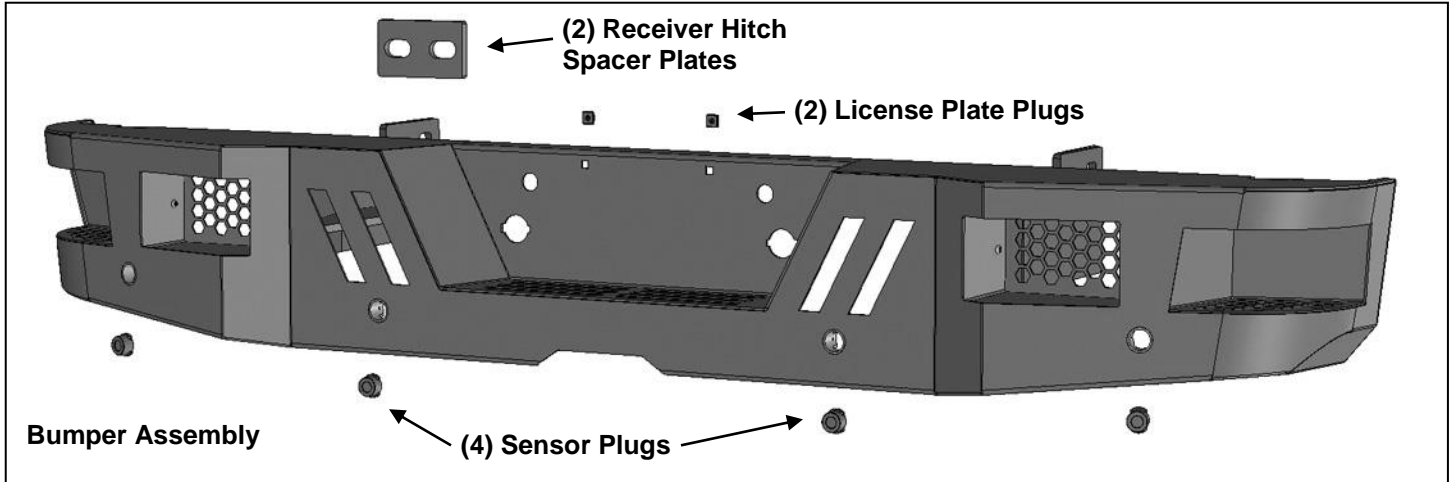

PROCEDURE:

REMOVE CONTENTS FROM BOX. VERIFY ALL PARTS ARE PRESENT. READ INSTRUCTIONS CAREFULLY BEFORE STARTING INSTALLATION. BUMPER IS HEAVY, ASSISTANCE IS HIGHLY RECOMMENDED TO AVOID POSSIBLE INJURY OR DAMAGE TO THE VEHICLE.

1. Remove the license plate and bracket. On models with back up sensors, unplug and remove the sensors. Unplug the factory license plate lights remove them from the bumper. Move the wiring harness away from the bumper, **(Figure 1)**. On some models, it may also be necessary to temporarily move the trailer/towing wiring harness from the bottom of the hitch and move it away from the hitch.
2. Place blocks or jack stands under the bumper to support it during mounting bolt removal. Once the bumper has been safely supported, remove the (2) large hex nuts per side attaching the bumper brackets to the sides of the frame, **(Figure 1)**. **WARNING!** Assistance is required to hold the bumper in place during hardware removal to prevent the bumper from falling. Remove the double bolt plates and slide the bumper off of the end of the frame, **(Figure 2)**.
3. On models equipped with receiver hitch, first remove the (4) hex bolts, (2) per side, attaching the rear of the hitch to the bottom of the frame, **(Figure 3)**. Allow the hitch to tilt down slightly. If necessary, use stands or blocks to temporarily support the hitch. Next, slightly loosen but do not remove the (4) hex bolts, (2) per side, attaching the hitch at the front. **IMPORTANT:** Only remove the rear hardware.
4. With assistance, position the ARMOUR Bumper Assembly up to the sides and end of the frame. Temporarily support the weight of the Bumper Assembly. **WARNING:** To avoid possible injury or damage to the vehicle, do not proceed until the Bumper is fully and safely supported.
5. Slide the mounting tab on the brackets on the Bumper between the hitch and the bottom of the frame. Line up the (2) holes in the passenger side vertical mounting plate with the (2) holes in the side of the frame. Reuse the factory double bolt plate and hardware to attach the bracket to the frame, **(Figures 5 & 8)**. Leave hardware loose. Repeat to attach the driver side mounting bracket to the frame.
6. Line up the hitch with the rear mounting holes toward the end of the frame and bottom mounting plate on the ARMOUR Bumper. Use the (4) factory hex bolts and nut plates to attach the hitch to the bottom mounting tabs, **(Figure 8)**. Leave hardware loose at this time.
7. With the rear of the hitch and the Bumper safely attached to the frame, remove the (4) hex bolts, (2) per side, attaching the hitch at the front. Select (1) 2-hole Space Plate, **(Figure 6)**. Insert the Spacer between the forward mount on the passenger/right side of the hitch and the bottom of the frame, **(Figures 7 & 8)**. Reuse the factory hex bolts to attach the hitch to the Spacer and frame. Repeat to install the Spacer on the driver/left side of the frame. Do not fully tighten the (4) front bolts at this time.
8. Level and adjust the bumper and fully tighten all hardware.
9. Reattach the wire harness to the bottom of the tow hitch of removed.

10. Select the (2) factory license plate lights. Push the lights into the holes in the Bumper.
11. Use the included (2) push-in plastic nuts to attach the license plate, (if required), to the (2) holes in the Bumper Assembly, **(Figure 9)**.
12. Remove screens in light housings for more room around lights as needed, **(Figure 10)**.
13. **Models with bumper mounted sensors:**
 - a. Remove the rubber plugs from the sockets in the bumper assembly. Push the sensor in from the back of the bumper. Secure each sensor to the socket with (2) 4mm x 10mm Button Head Screws, **(Figure 11)**. **IMPORTANT:** Sensors fit snug in sockets. The 4mm Screws are used to apply slight pressure to lock the sensors in place. Tighten both screws evenly until they touch the sensor body only. Do not overtighten screws or damage to sensors will result.
14. Reattach all wiring harnesses and use the included Wire Ties to secure the wiring harness to the bumper and frame.
15. Do periodic inspections to the installation to make sure that all hardware is secure and tight.

To protect your investment, wax this product after installing. Regular waxing is recommended to add a protective layer over the finish. Do not use any type of polish or wax that may contain abrasives that could damage the finish. Mild soap may be used to clean the ARMOUR Bumper assembly.

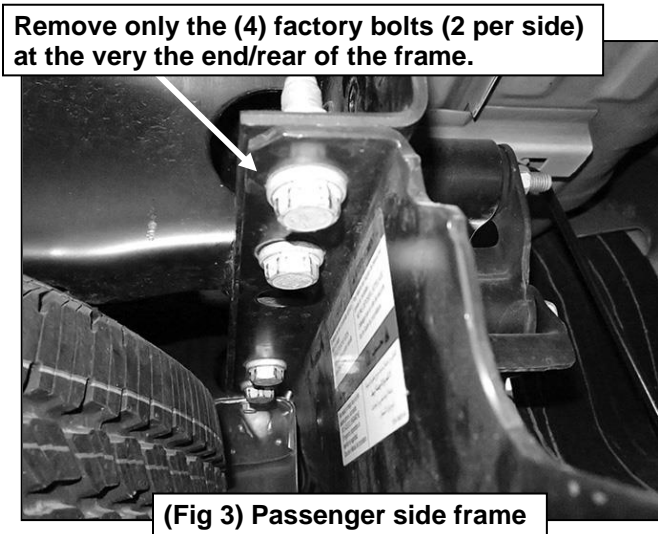
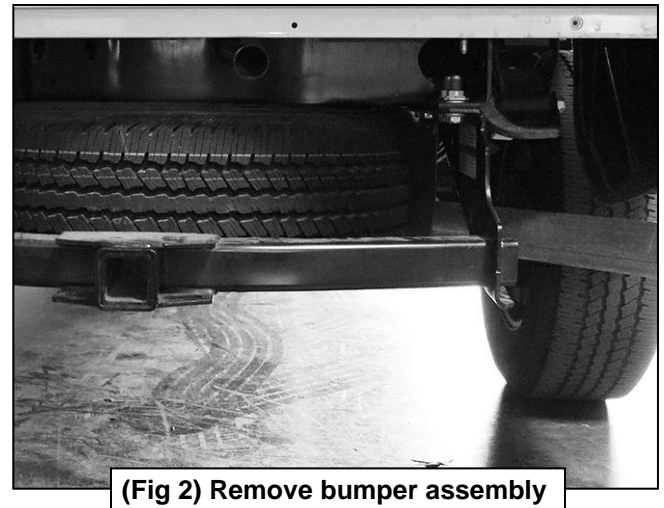
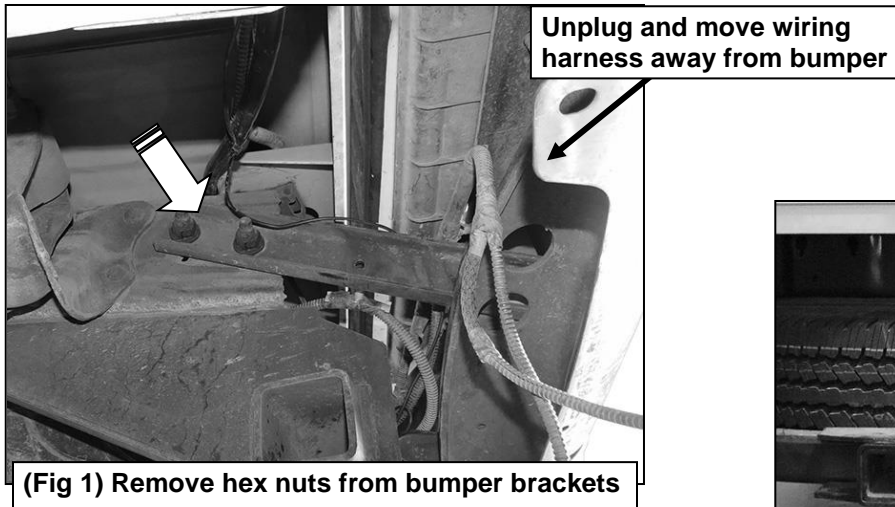

WARNING! Do not remove bumper bolts unless the bumper is properly supported on blocks or stands or the bumper may fall.

Passenger/right Side Installation Pictured

Remove double
bolt plate



(Fig 4) Passenger side mounting location

WARNING! Do not crawl under bumper unless the bumper is properly supported on blocks or stands or the bumper may fall.

Reuse factory double
bolt plate and hardware

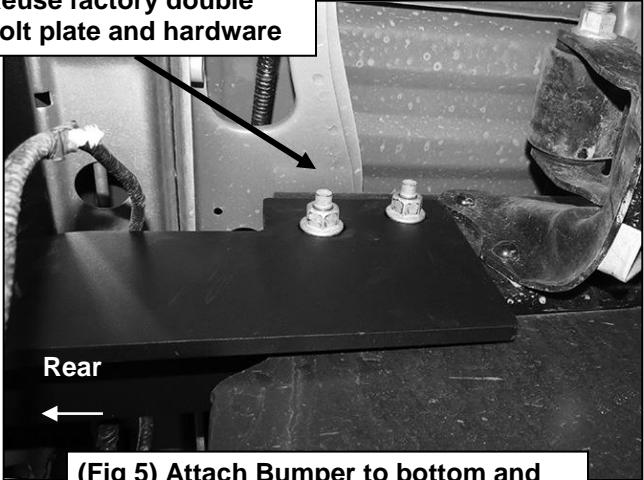

(Fig 5) Attach Bumper to bottom and side of frame (passenger side pictured)



(Fig 6) Hitch Front Spacer

Factory double
bolt plate

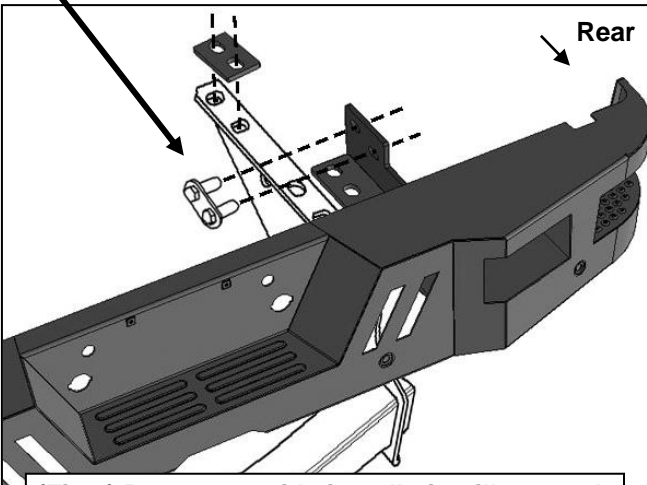

(Fig 8) Passenger side installation illustrated

Insert 2-hole Spacer Plate
between front mounting tab on
hitch and bottom of frame (arrow)



(Fig 7) Driver side installation with hitch

Passenger/right Side Installation Pictured

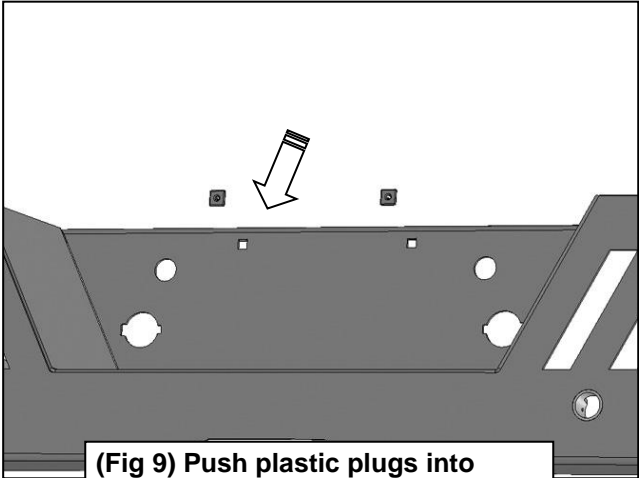

(Fig 9) Push plastic plugs into holes in Bumper for license plate

Remove screens if necessary for additional clearance around or access to lights

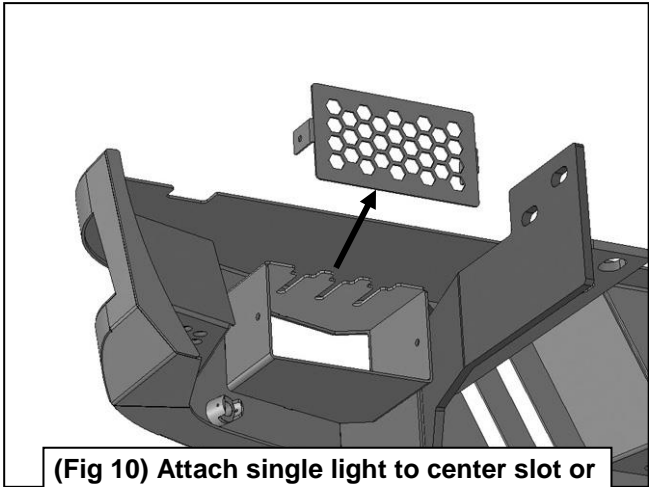

(Fig 10) Attach single light to center slot or use inner and outer slots for dual lights

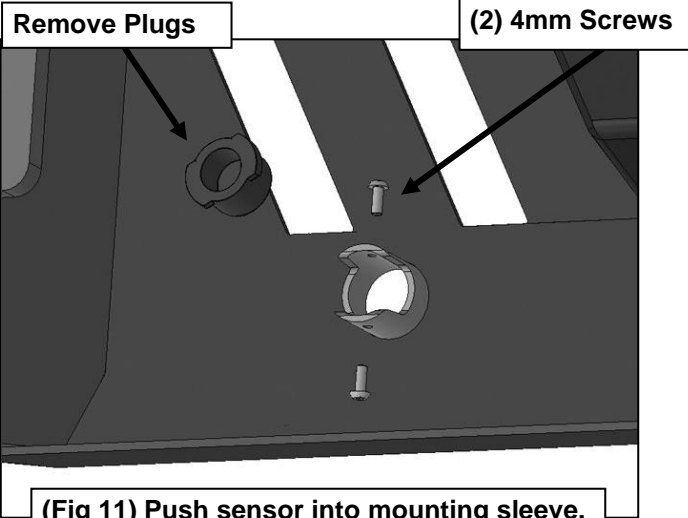

(Fig 11) Push sensor into mounting sleeve. Use 4mm Screws to lock sensor in place.



Complete Installation