



INSTALLATION INSTRUCTIONS

**ARMOUR BULL BAR
FOR 2017-2018 FORD SUPER DUTY F250-F550**

PART#AB-FO20

PARTS LIST:

1	Bull Bar	2	8-1.25mm x 20mm Hex Bolts
1	Driver/Left Side Frame Bracket	2	8-1.25mm x 16mm Hex Bolts
1	Passenger/Right Side Frame Bracket	8	8mm x 24mm x 2mm Flat Washers
1	Driver/Left Side Light Bar Bracket	4	8mm Lock Washers
1	Passenger/Right Side Light Bar Bracket	2	8mm Hex Nuts
1	Mesh	2	6-1.0mm x 20mm Combo Bolts
1	License Plate Bracket	2	6-1.0mm x 20mm Button Head Bolts
2	Rubber Sensor Plugs	4	6mm x 18mm x 1.6mm Flat Washers
2	Spacer Plates	2	6mm Lock Washers
4	10-1.5mm x 25mm Hex Bolts	2	6mm Hex Nuts
4	10mm x 30mm x 2.5mm Flat Washers	4	4mm x 10mm Button Head Bolts (Backup Accessories)
4	10mm Lock Washers	1	Wrench S=4 (Backup Accessories)
2	8mm Nylon Lock Nuts	1	Wrench S=2.5

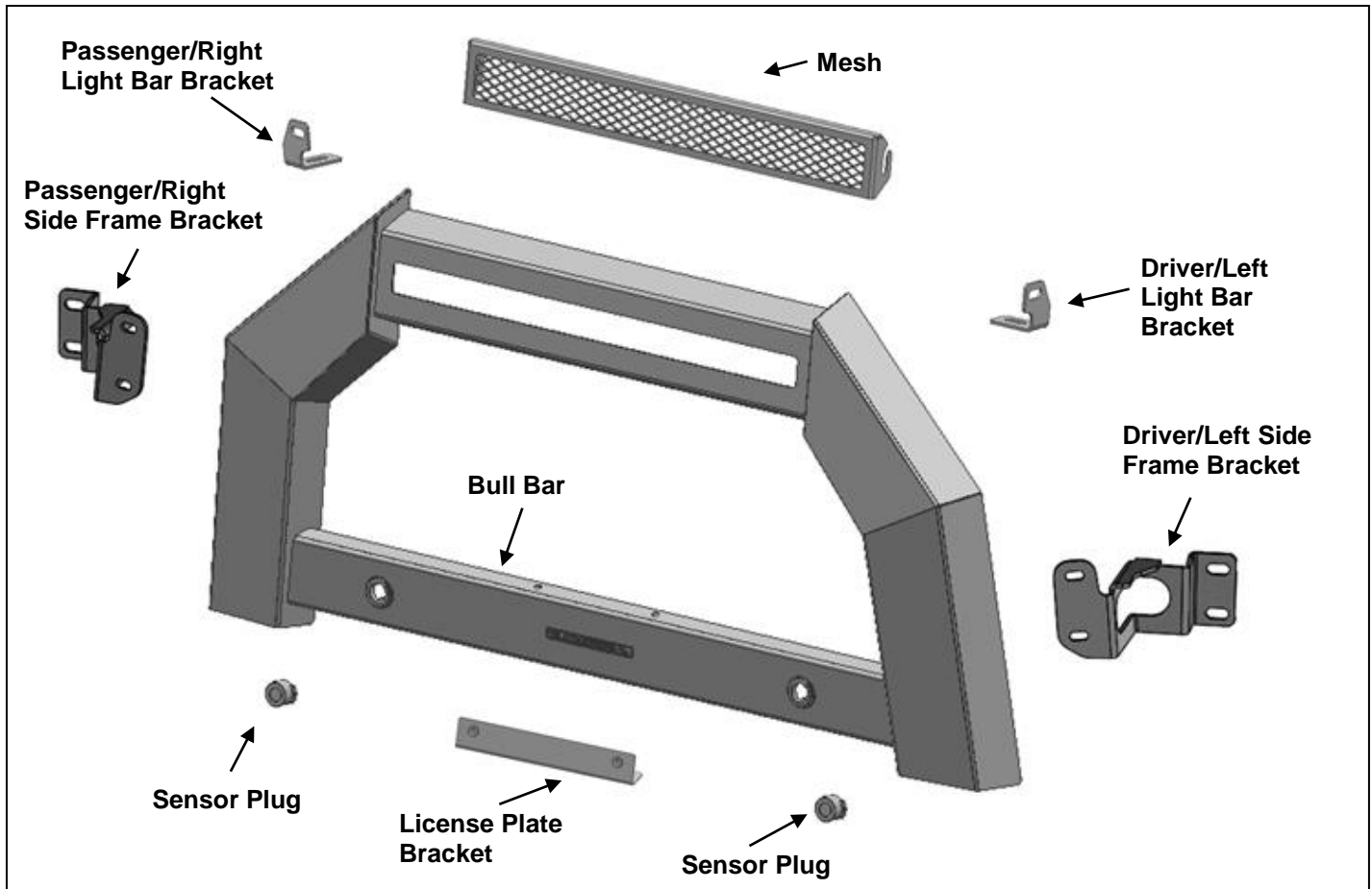

PROCEDURE:

REMOVE CONTENTS FROM BOX. VERIFY ALL PARTS ARE PRESENT. READ INSTRUCTIONS CAREFULLY BEFORE STARTING INSTALLATION. ASSISTANCE IS RECOMMENDED.

1. Start installation at the driver/left side, front of the vehicle. Remove the plastic cover, (if equipped), covering the bumper bolts on both sides of the tow hook, **(Figure 1)**. Remove the (2) outer bumper bolts, **(Figures 2 & 3)**. **IMPORTANT:** Do not remove the inner bumper bolts or the bumper may fall. Only remove the outer bumper bolts. **NOTE:** Cover cannot be reinstalled.
2. Select the driver side Frame Bracket and (1) Spacer Plate, **(Figure 4)**. Place the Spacer over the holes for the bumper bolts. Reuse the factory bumper bolts to attach the Frame Bracket to the Spacer and bumper, **(Figure 5)**. Make sure there is clearance between the top and bottom of the Frame Bracket and the opening in the bumper. Do not tighten hardware at this time.
3. Repeat **Steps 1 & 2** for passenger/right side Frame Bracket and Spacer installation.
4. Relocation of front license plate is not required, but strongly recommended.
 - a. Attach the License Plate Bracket to the Bull Bar with (2) 6mm Button Head Bolts, (4) 6mm Flat Washers, (2) 6mm Lock Washers and (2) 6mm Hex Nuts, **(Figure 6)**. Use (2) 6mm Combination Bolts to attach the front license plate to the Bracket, **(Figure 6)**.
5. **Mesh and LED Light installation, (LED light sold separately)**. Select the driver/left side Light Bar Bracket. Attach the Bracket to the back of the mounting plate on the Bull Bar with (1) 8mm x 20mm Hex Bolt, (2) 8mm Flat Washers, (1) 8mm Lock Washer and (1) 8mm Hex Nut, **(Figure 7)**. Repeat this step to attach the passenger/right side Light Bar Bracket to the back of the Bull Bar. Do not tighten hardware.

LED Light Installation

- a. Use (2) 8mm x 16mm Hex Bolts, (2) 8mm Lock Washers and (2) 8mm Flat Washers to attach the Light Bar Brackets to the Bull Bar, **(Figure 8)**.
- b. Follow the light manufacturer's instructions to attach the Bull Bar.
- c. Follow light manufacturer's instructions to properly wire the Bull Bar.

Mesh installation

- a. Use (2) 8mm x 16mm Hex Bolts, (4) 8mm Flat Washers, (2) 8mm Lock Washers and (2) 8mm Hex Nuts to attach the Mesh to the inside surface of the Light Bar Brackets, **(Figure 9)**.
- b. Level and adjust the Brackets to the Mesh Panel and fully tighten hardware.
6. With assistance, hold up the assembled Bull Bar to the Frame Brackets. Align the (4) bottom holes on the Uprights with the Frame Brackets. Bolt the assembled Bull Bar to the Brackets with (4) 10mm x 25mm Hex Bolts, (4) 10mm Lock Washers and (4) 10mm x 30mm Flat Washers, **(Figures 10 & 11)**. Do not tighten hardware at this time.
7. Select the (2) Sensor Plugs. Push the sensor plugs into the sensor sleeves behind the Bull Bar, **(Figure 12)**.
8. Center the Bull Bar on the vehicle, level and adjust as desired and tighten all hardware at this time.
9. Do periodic inspections to the installation to make sure that all hardware is secure and tight.

To protect your investment, wax this product after installing. Regular waxing is recommended to add a protective layer over the finish. Do not use any type of polish or wax that may contain abrasives that could damage the finish. Mild soap may be used to clean the Bull Bar.

Driver/left Side Installation Pictured

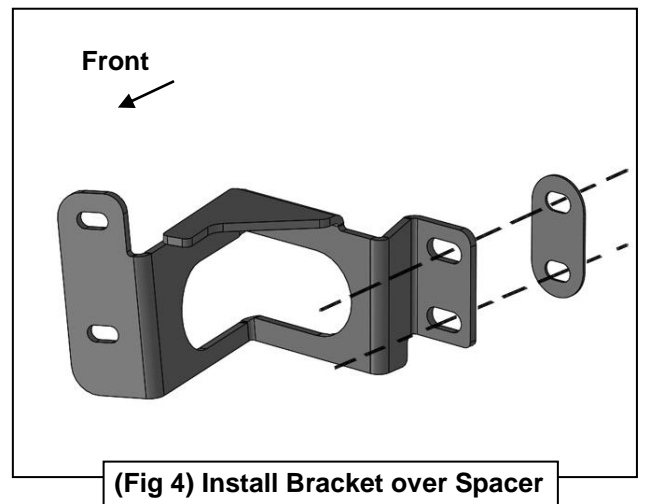
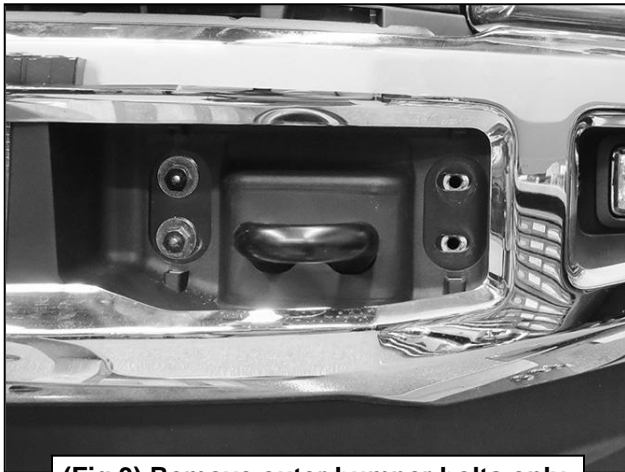
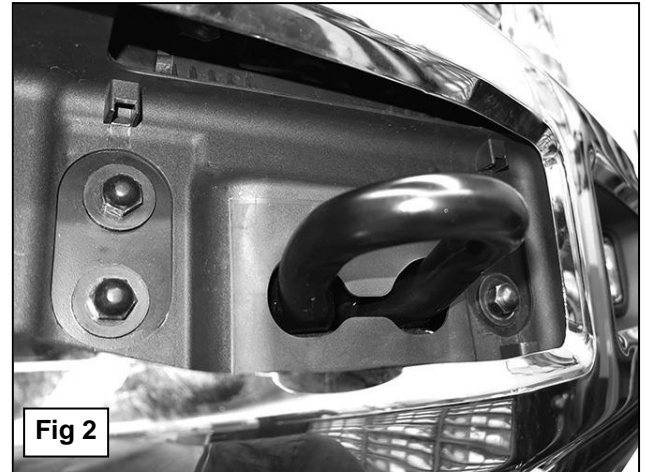

Driver/left Side Installation Pictured

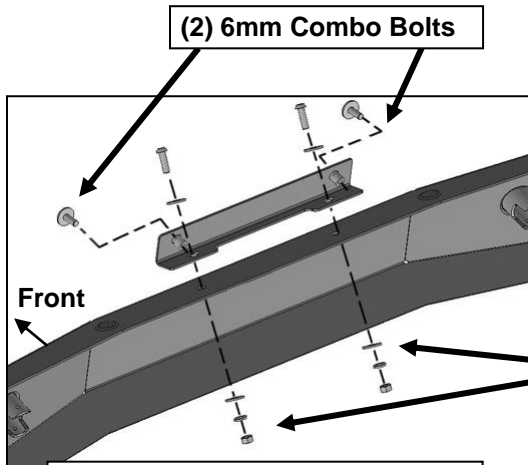

(Fig 6) License Plate Bracket attached to the Bull Bar

- (2) 6mm Button Head Bolts
- (4) 6mm Flat Washers
- (2) 6mm Lock Washers
- (2) 6mm Hex Nuts

- (1) 8mm x 20mm Hex Bolt
- (2) 8mm Flat Washers
- (1) 8mm Lock Washer
- (1) 8mm Hex Nut

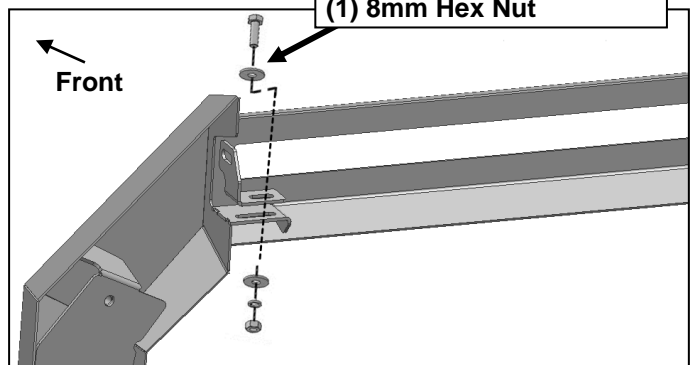

(Fig 7) Driver side light bar Bracket attached to the Bull Bar

- 8mm x 16mm Hex Bolt
- 8mm Lock Washer
- 8mm Flat Washer

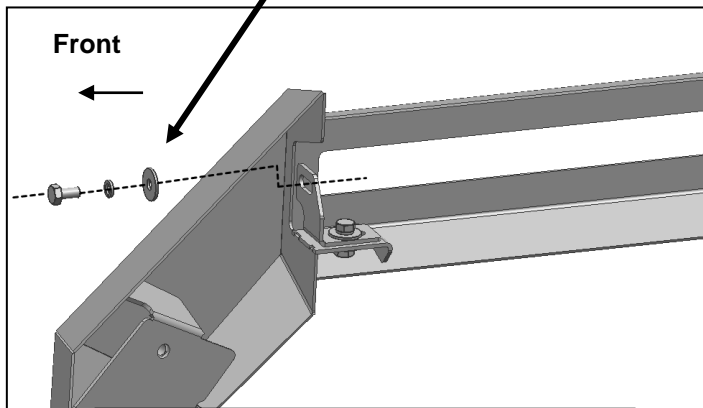

(Fig 8) Driver side light bar Bracket attached to the Bull Bar hardware

- (1) 8mm x 16mm Hex Bolt
- (2) 8mm Flat Washers
- (1) 8mm Lock Washer
- (1) 8mm Hex Nut

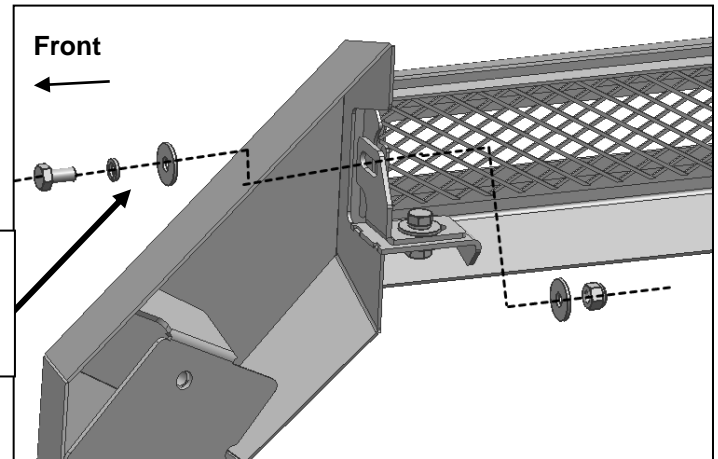

(Fig 9) Driver side light bar Bracket attached to Mesh hardware

Driver Side Installation Pictured

