



INSTALLATION INSTRUCTIONS

S/S MODULAR GRILLE GUARD FOR DODGE SPRINTER

07-09/FREIGHTLINER SPRINTER 07-16/07-11MERCEDES-BENZ

SPRINTER (FULL SIZE)

PART # 17D502MSS

Before Installation





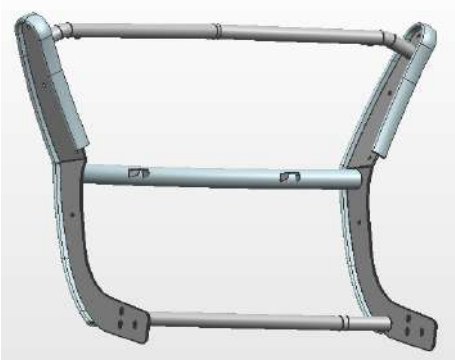
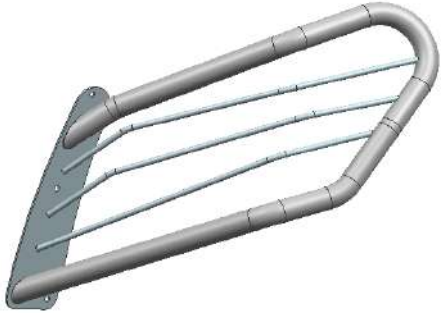
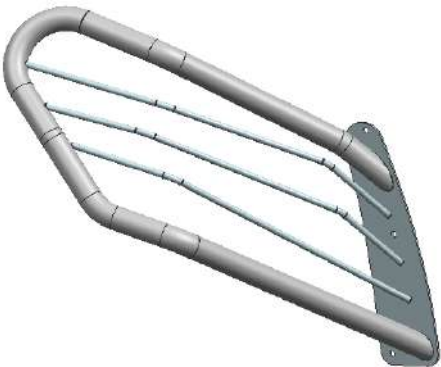
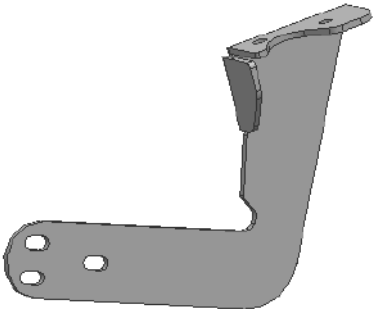

- Please read the instruction completely for easy installation, which will also help you to avoid scratches or other potential damages to your appealing car.
- The figures here are for reference only and may have differences with the actual product you received, however they share the same assembly way.

Care and Cleaning

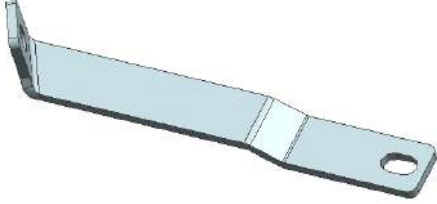
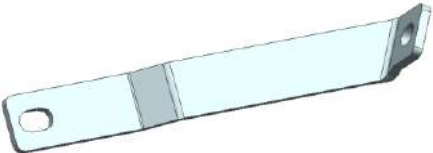
- Mild soap may be used also to clean the Product.
- Please periodically check and retighten all the hardware and clean the investment for a refresh look.

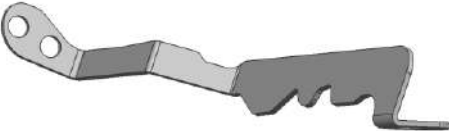
Parts list

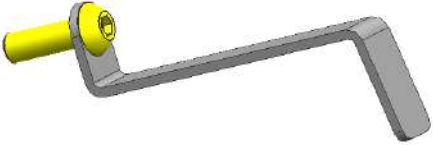
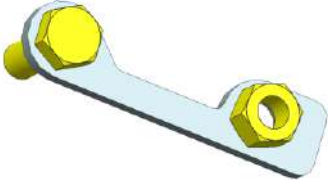
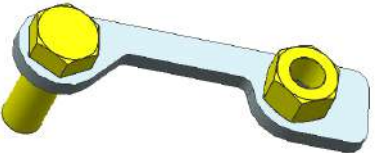
NO.	QTY	PIC	NO.	QTY	PIC
①	1	 Front Guard	②	1	 Left Brush Guard
③	1	 Right Brush Guard	④	1	 Left Bracket

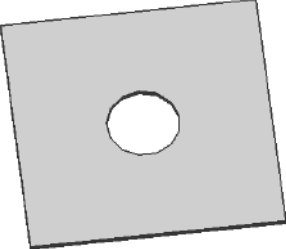
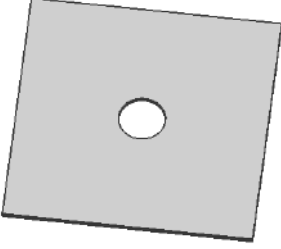
<p>⑤</p> <p>1</p>	 <p>Right Bracket</p>		<p>⑥</p> <p>1</p>	 <p>Left Connecting Bracket</p>
<p>⑦</p> <p>1</p>	 <p>Right Connecting Bracket</p>		<p>⑧</p> <p>1</p>	 <p>Left Connecting Bracket (for 07-14 type)</p>
<p>⑨</p> <p>1</p>	 <p>Right Connecting Bracket (for 07-14 type)</p>		<p>⑩</p> <p>2</p>	 <p>Connecting Bracket (for 15+ type)</p>
<p>⑪</p> <p>2</p>	 <p>Z Bolt Plate</p>		<p>⑫</p> <p>1</p>	 <p>Left Bolt Plate</p>
<p>⑬</p> <p>1</p>	 <p>Right Bolt Plate</p>		<p>⑭</p> <p>2</p>	 <p>Tube Spacer</p>
<p>⑮</p> <p>2</p>	 <p>M12 Plastic Block</p>		<p>⑯</p> <p>2</p>	 <p>M8 Plastic Block</p>

Installation Steps

No.	Description	Qty.	No.	Description	Qty.
⑰	Hex Bolt M8_20	2	⑳	Hex Nut M12	8
⑱	Flat Washer D10	4	㉑	Hex Bolt M8_40	2
㉒	Flat Washer D8	8	㉒	Hex Bolt M12_35	8
㉓	Spring Washer D8	6	㉓	Nylon Lock Nut M8	6
㉔	Spring Washer D12	10	㉔	Flat Washer D8(8x24x2mm)	14
㉕	Flat Washer D12	16	㉕	Hex Bolt M8_25	6
㉖	Hex Bolt M10_30	2	㉖	Button Head Bolt M8_30	2
㉗	Nylon Lock Nut M10	2	㉗	Allen Wrench S=5	1
㉘	Hex Nut M8	2			

INSTALLING PICTURE

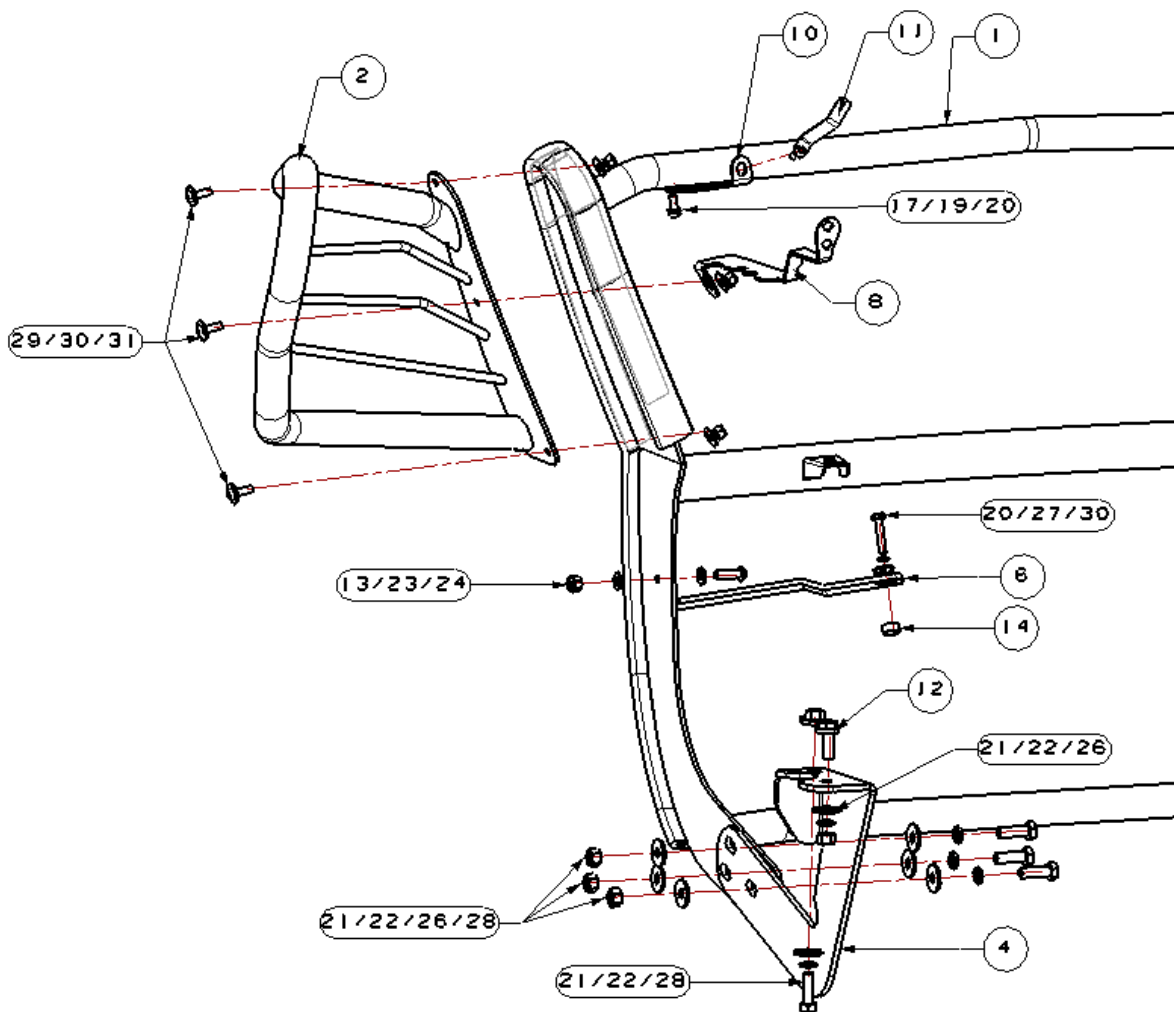

PROCEDURE:

1. REMOVE CONTENTS FROM BOX. VERIFY ALL PARTS ARE PRESENT. READ INSTRUCTIONS CAREFULLY BEFORE STARTING INSTALLATION. DRILLING IS REQUIRED. ASSISTANCE IS RECOMMENDED.
2. Starting on the driver side of the vehicle, locate the factory hole in the bottom of the frame channel, **(Figure 1)**. Insert (1) 12mm Bolt and Nut Plate into the frame rail, **(Figures 1 & 2)**. **NOTE:** Insert Bolt Plate with welded nut toward the front of the vehicle. The offset Bolt and Nut Plate is designed to clear hardware that may be attached to the inside of the frame, **(Figure 1)**.
3. Hang the driver side Frame Mounting Bracket from the Bolt and Nut Plate with (1) 12mm Flat Washer, (1) 12mm Lock Washer and (1) 12mm Hex Nut, **(Figures 3A & 3B)**. Do not tighten hardware at this time.
4. Repeat **Steps 2 & 3** to install the passenger side Frame Mounting Bracket.
5. Next, remove the (2) Torx bolts in the bottom of the opening in the front bumper step area, **(Figure 4)**. Place a Tube Spacer into the driver side recess in the bumper cover, **(Figure 5A & 5B)**. Position the driver side Center Bracket over the Tube Spacer. Use the included 8mm x 40mm Hex Bolt, 8mm Lock Washer and 8mm x 24mm Large Flat Washer to attach the Bracket to the bumper, **(Figure 6)**. Do not tighten hardware at this time. Repeat this **Step** for passenger side Center Bracket installation.
6. With assistance, position the Grille Guard up to the outside of the Frame Mounting Brackets. Line up the rear-most holes in the Mounting Brackets with the Grille Guard. Insert (1) 12mm x 35mm Hex

Bolt, (1) 12mm Lock Washer, (2) 12mm Flat Washers and (1) 12mm Hex Nut per side into the rear mounting holes to act as a hinge. Rotate the Grille Guard up into position. Install the included 12mm Hex Bolts into the remaining mounting holes, **(Figure 7)**. Do not tighten hardware at this time.

7. Attach the driver side Center Bracket to the Grille Guard with the included (1) 10mm x 25mm Button Head Bolt, (2) 10mm Flat Washers and (1) 10mm Nylon Lock Nut, **(Figure 8)**. Do not tighten hardware at this time. Repeat this Step for passenger side Center Bracket installation.

Determine correct procedure for Top Support Bracket installation for your model year.

2007-14 models:

- a. Open the hood and locate the factory hole in the driver side of the radiator cross member. Remove the factory screw below the hole securing the top of the grille to the cross member, **(Figure 9)**.
- b. Insert (1) 8mm "Z" Bolt Plate through the back of the cross member and out of the hole, **(Figures 10 & 11)**. **NOTE:** The back of the cross member may be obstructed. Carefully move the coolant tank or air intake if necessary to access the back of the cross member.
- c. Use 2-3 8mm x 16mm Flat Washers on the "Z" Bolt Plate as a spacer between the cross member and the Top Bracket, **(Figure 12)**. **NOTE:** It may be necessary to push down slightly on the top of the grille to provide clearance for the Spacer Washers.
- d. Secure the Top Bracket to the 8mm Bolt Plate using (1) 8mm x 16mm Flat Washer, (1) 8mm Lock Washer and (1) 8mm Hex Nut, **(Figure 13)**. Reinstall the factory screw through the hole in the Top Bracket, **(Figure 13)**. Leave hardware loose at this time.
- e. Remove the top 6mm Button Head Bolt securing the headlight wire assembly to the Grille Guard upright, **(Figure 14)**. Bolt the Top Support Bracket to the inside of the upright using the included longer 6mm x 25mm Button Head Bolt, 6mm STD Flat Washer (outside), 6mm x 22mm Large Flat Washer, (inside against the Top Bracket), and 6mm Nylon Lock Nut, **(Figures 14 & 15)**.
- f. Repeat the above Steps for passenger side Top Bracket installation.

2015-16 models:

- a. Open the hood and locate the driver side of the radiator cross member. Remove the plastic retaining clip attaching the top of the grille to the cross member, **(Figure 16)**.
 - b. Insert (1) 8mm "Z" Bolt Plate through the back of the cross member and out of the hole, **(Figure 17)**. **NOTE:** The back of the cross member may be obstructed. Carefully move the coolant tank or air intake if necessary to access the back of the cross member.
 - c. Select (1) 2015-16 Top Bracket. Attach the Top Bracket to the 8mm Bolt Plate with (1) 8mm x 16mm Flat Washer, (1) 8mm Lock Washer and (1) 8mm Hex Nut, **(Figures 17 & 18)**. Leave hardware loose at this time.
 - d. Line up the outer end of the Top Bracket with the threaded insert on the bottom of the top tube on the Grille Guard. Attach the Bracket to the tube with (1) 6mm x 25mm Button Head Bolt and (1) 6mm Flat Washer, **(Figure 19)**.
 - e. Repeat the above Steps for passenger side Top Bracket installation.
8. Align Grille Guard properly and tighten all hardware.
 9. Once you have the Grille Guard completely installed and properly aligned, use the second hole, (unused till now), in both Frame Mounting Brackets as a template to mark the drilling location on the bottom of the frame channel, **(Figure 20)**. **Do not** mark the frame until after the Grille Guard has been completely installed and properly aligned and adjusted. No adjustments can be made after the frame has been drilled.
 10. Remove the Grille Guard, Frame Brackets and 12mm Bolt and Nut Plates from the vehicle. **NOTE:** It is not necessary to remove the Center or Top Brackets from the vehicle.

11. Use a 1/2" drill bit to drill out the marked location, **(Figure 21)**. **IMPORTANT:** Any cutting or drilling tool may break or shatter. Government regulations require safety glasses & equipment at all times when cutting or drilling.
12. Reinsert the Bolt and Nut Plates, **(Step 2)**. Rotate the 12mm Bolt and Nut Plate to line up the threaded nut with the previously drilled 1/2" hole. Use the included (2) 12mm x 35mm Hex Bolts, (2) 12mm Lock Washers and (2) 12mm Flat Washers to secure the Frame Brackets to the 12mm x 35mm Bolt and Nut Plate, **(Figures 22A & 22B)**. Re-install the Grille Guard as previously described in **Steps 2—8**. **NOTE:** Align Grille Guard properly and fully tighten all hardware.
13. Do periodic inspections to the installation to make sure that all hardware is secure and tight.

To protect your investment, wax this product after installing. Regular waxing is recommended to add a protective layer over the finish. Do not use any type of polish or wax that may contain abrasives that could damage the finish.

For stainless steel: Aluminum polish may be used to polish small scratches and scuffs on the finish. Mild soap may be used also to clean the Grille Guard.

For gloss black finishes: Mild soap may be used to clean the Grille Guard.

Driver Side Installation Pictured

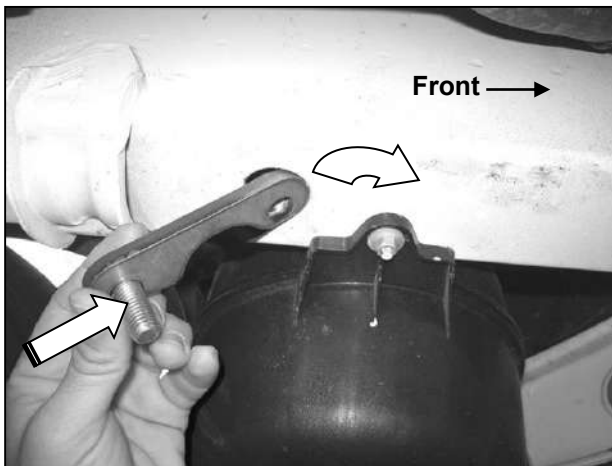

(Fig 1) Insert Bolt/Nut Plate into hole in frame

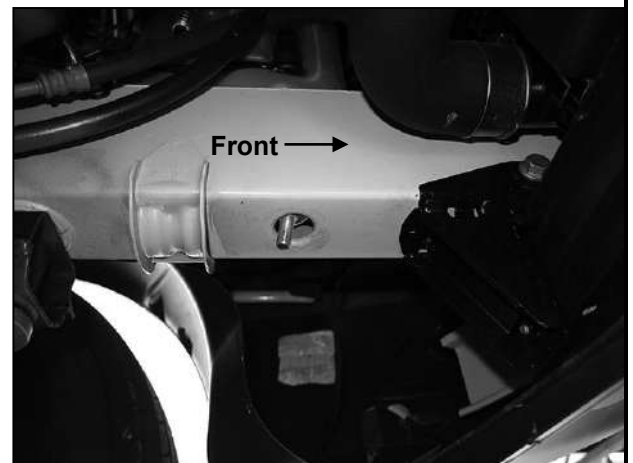
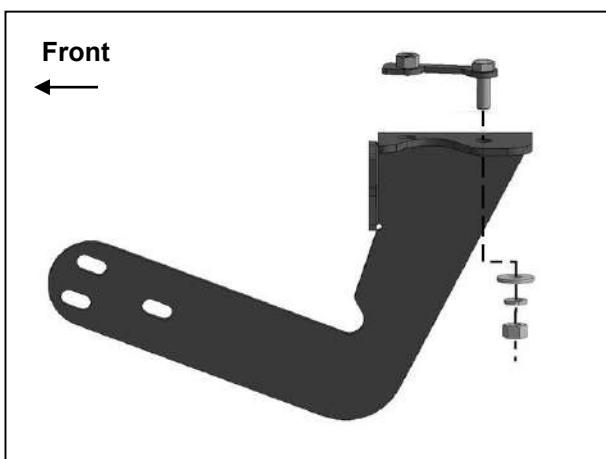
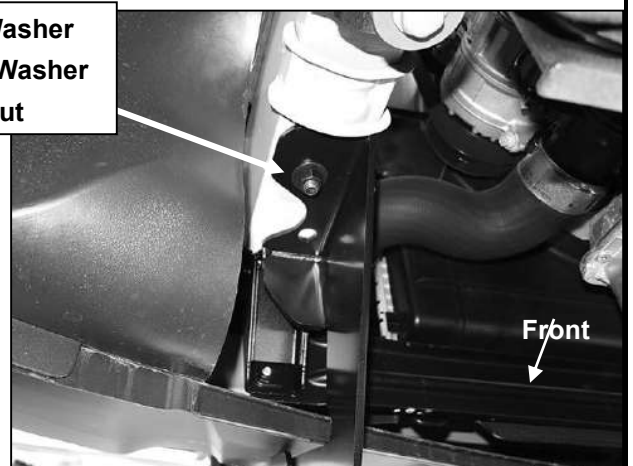

Fig 2



(Fig 3A) Driver/left Frame Bracket

12mm Flat Washer
12mm Lock Washer
12mm Hex Nut



(Fig 3B) Driver/left Frame Bracket installed

Driver Side Installation Pictured

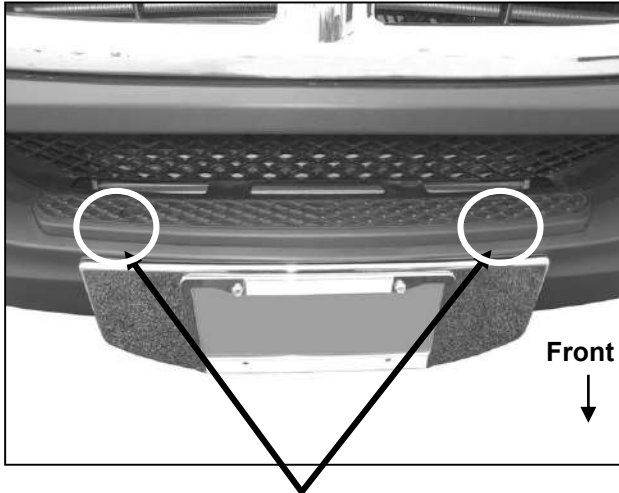

(Fig 4) Remove (2) factory screws (Torx head)

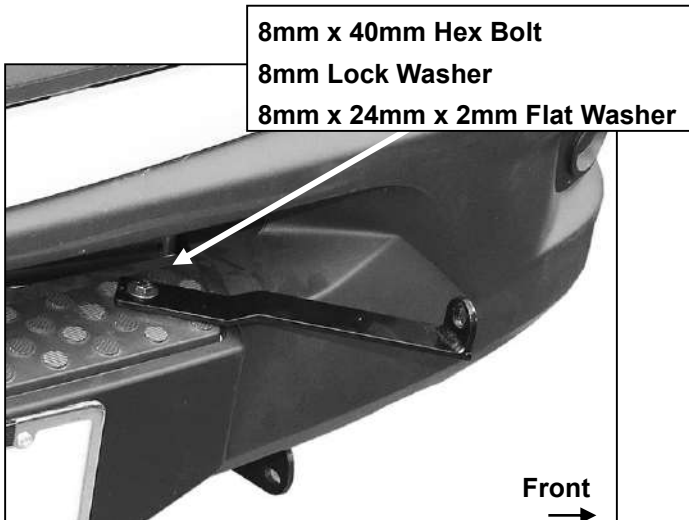

(Fig 6) Attach driver/left Center Bracket to bumper

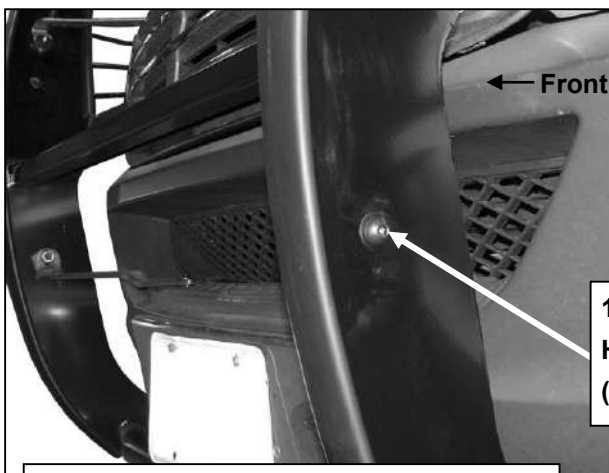

(Fig 8) Attach Center Bracket to upright



(Fig 5A) Tube Spacer

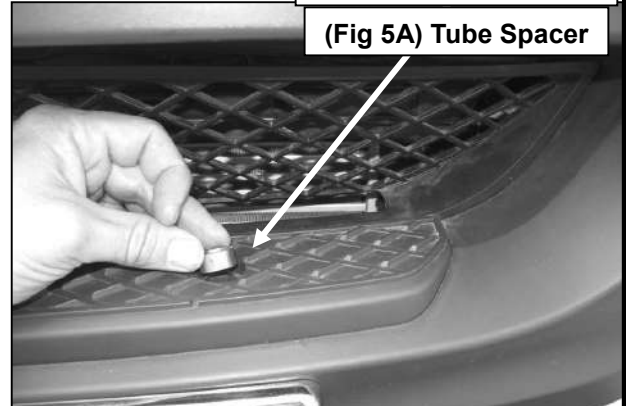

(Fig 5B) Insert Spacer into recess in bumper



(Fig 7) Attach Grille Guard to Frame Brackets

**10mm x 30mm Button Head Bolt
(2) 10mm Flat Washers**

Driver Side Installation Pictured

Factory hole in radiator cross member (driver/left side pictured)

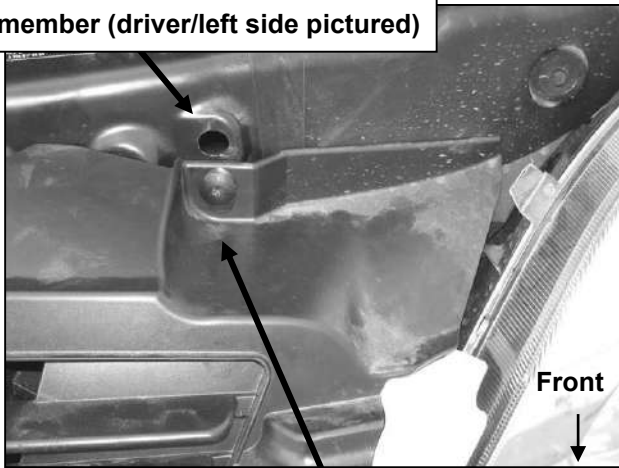

(Fig 9) 07-14 Models-Remove factory screw

Insert 8mm x 25mm "Z" Bolt Plate into the factory hole (see Fig 9) from behind the

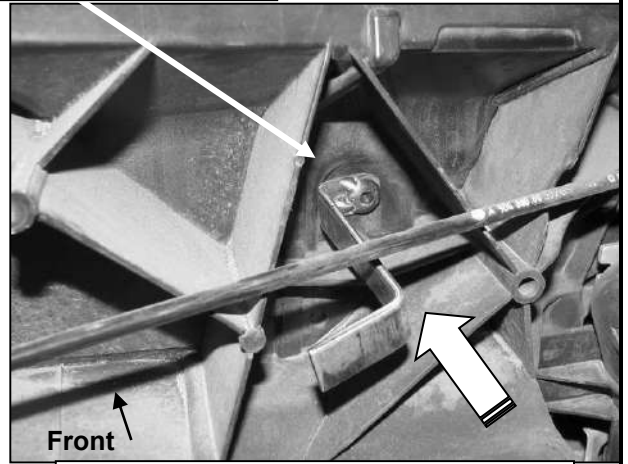

(Fig 10) Back of radiator cross member (driver/left side pictured)

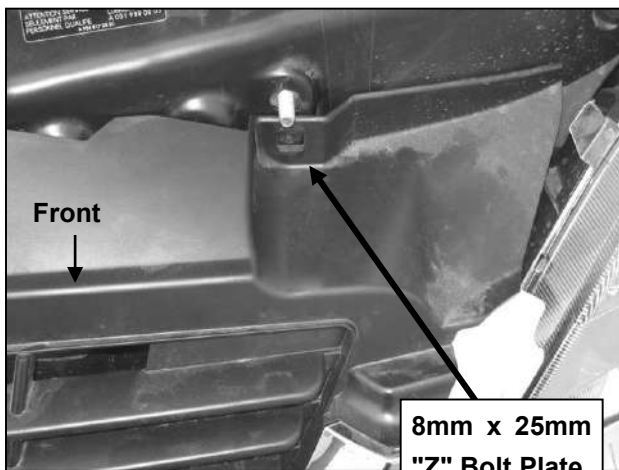
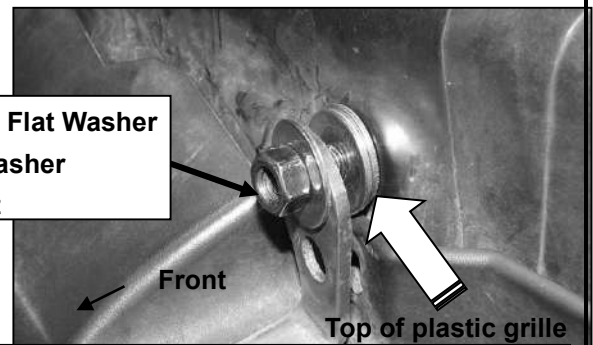

Fig 11

8mm x 25mm "Z" Bolt Plate

8mm x 16mm Flat Washer
8mm Lock Washer
8mm Hex Nut



(Fig 12) Insert (2-3) 8mm x 16mm Flat Washers as a spacer (arrow) between the Top Bracket and the radiator cross member. NOTE: It may be necessary to gently push down on the plastic grille to provide clearance for the Flat Washers/Spacer behind the Top Bracket.

Reinstall the factory button head screw (see Fig 9)

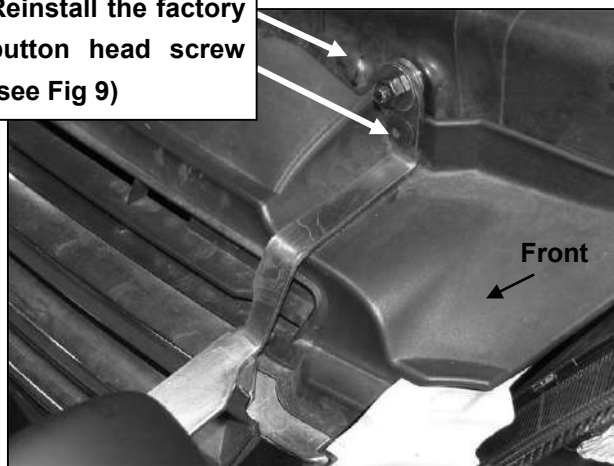

(Fig 13) 07-14 model, driver/left side pictured

Driver Side Installation Pictured

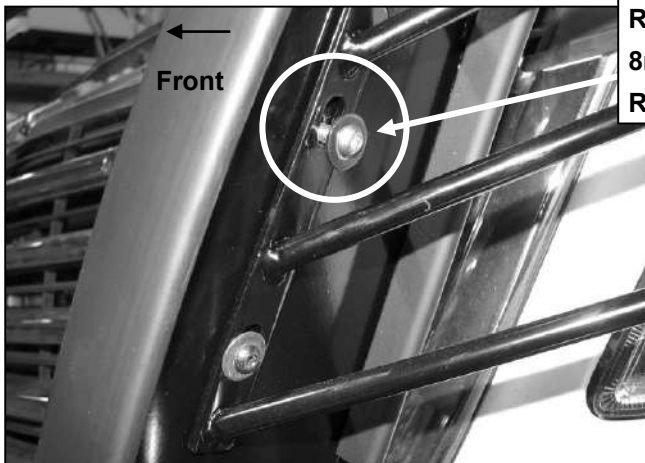

Replace top button head bolt with
8mm x 25mm Button Head Bolt
Reuse the 6mm STD Flat Washer

Fig 14

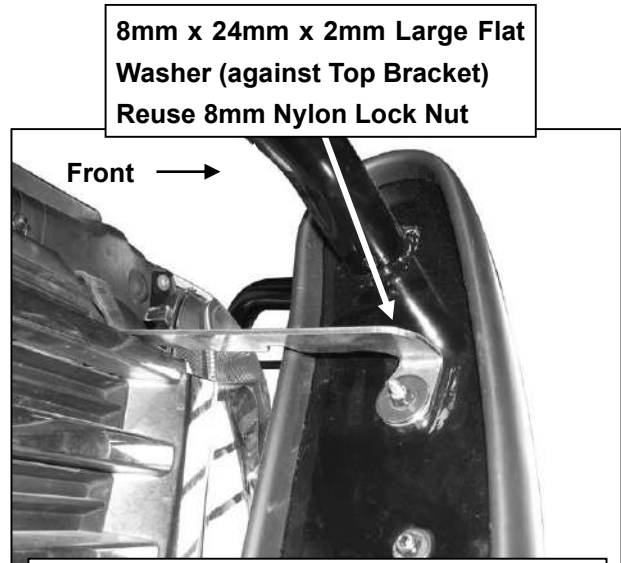

8mm x 24mm x 2mm Large Flat
Washer (against Top Bracket)
Reuse 8mm Nylon Lock Nut

**(Fig 15) 07-14 model-attach top Support
Bracket to 6mm Button Head Bolt in upright**

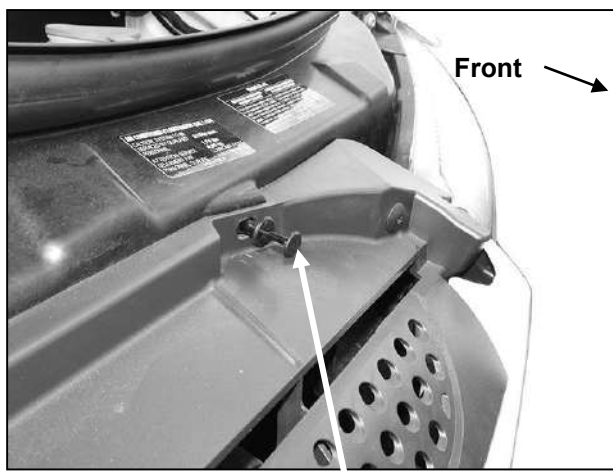

**(Fig 16) 2015-16 models, remove top outer
plastic clip (driver/left side pictured)**

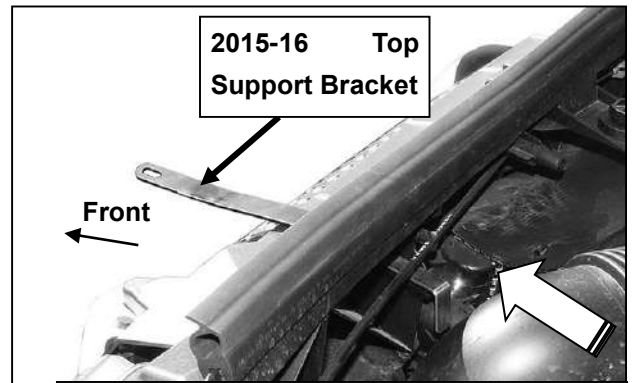

**2015-16 Top
Support Bracket**

**(Fig 17) Insert 8mm "Z" Bolt Plate through
back of radiator cross member (arrow)**

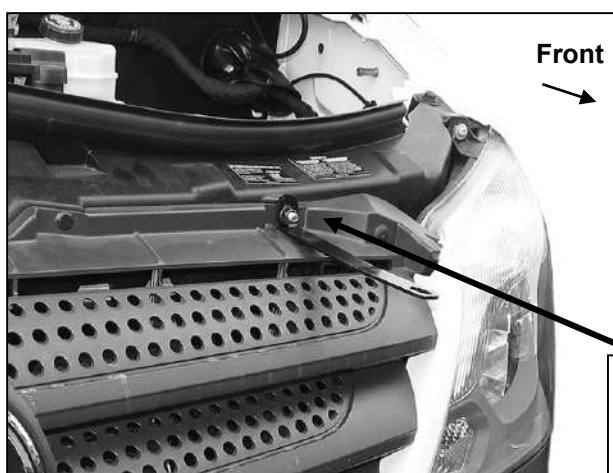

8mm x 16mm Flat Washer
8mm Lock Washer
8mm Hex Nut

**(Fig 18) 2015-16 models, attach Top
Support Bracket to 8mm Z Bolt Plate**

Driver Side Installation Pictured

6mm x 25mm Button Head Bolt
6mm Flat Washer



(Fig 19) 2015-16 model, driver/left side pictured

Mark hole location onto bottom of frame channel.
Remove Grille Guard

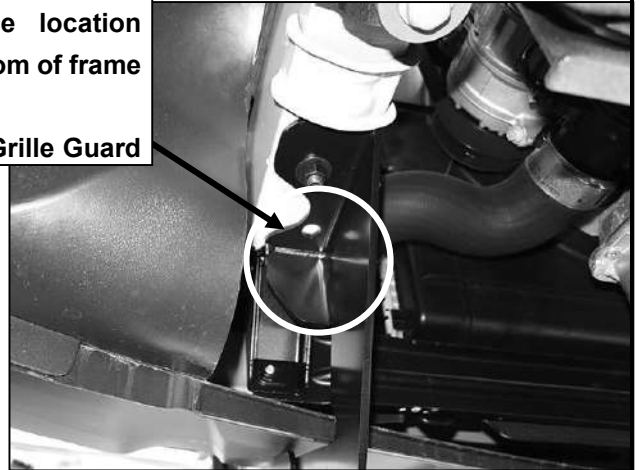

(Fig 20) Driver/left Frame Bracket pictured

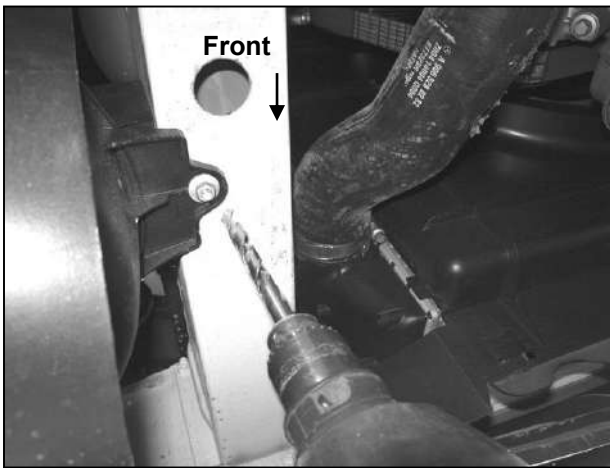

(Fig 21) Drill 1/2" hole in bottom of frame channel

12mm x 35mm Hex Bolt
12mm Lock Washer

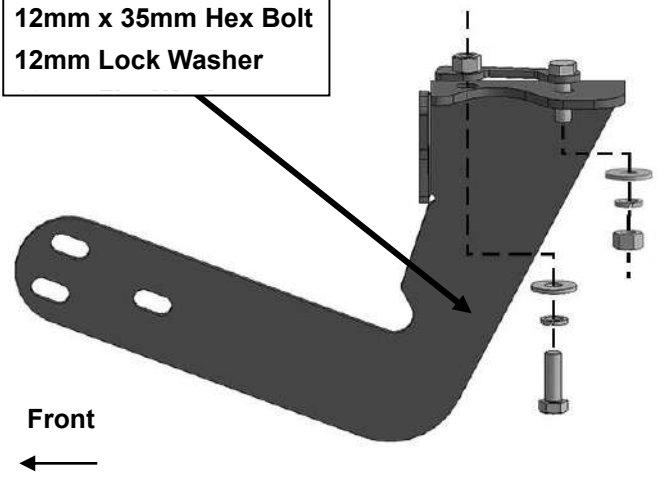

Fig 22B

12mm x 35mm Hex Bolt
12mm Lock Washer
12mm Flat Washer

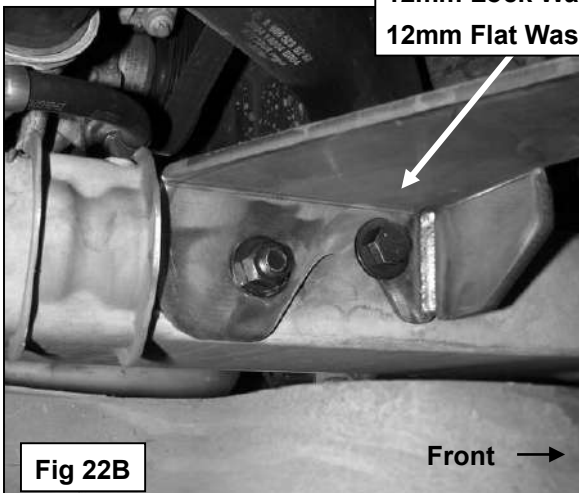

Fig 22B

Complete Installation

Any damages and losses caused by improper installation and application, goes beyond our quality warranty.

Rely on premium grille guards and bull bars by Black Horse if you're looking for quality and efficiency.