



# **INSTALLATION INSTRUCTIONS**

**PART#: SR-DOR303285**

**SPARTAN RUNNING BOARD**

**DODGE PROMASTER 136"/159" wheel base 14-UP**

**PARTS LIST:**

1	Driver/left Spartan Running Board	12	8-1.25mm x 25mm Hex Bolts
1	Passenger/right Spartan Running Board	6	8mm x 28mm OD x 3mm Large Flat Washers
1	Driver/Left Side Front Bracket	24	8mm x 16mm OD x 1.6mm Small Flat Washers
1	Driver/Left Side Rear Bracket	6	8mm Lock Washers
1	Driver/Left Side Front Support Bracket	6	8mm Hex Nuts
1	Passenger/Right Side Front Bracket	12	8mm Nylon Lock Nuts
3	Passenger/Right Side Center/Rear Brackets	6	6mm Double Bolt Plates
5	Passenger/Right Side Support Brackets (1-driv rear)	12	6mm x 22mm OD x 2mm Flat Washers
6	8-1.25mm x 40mm Button Head Bolt Plates	12	6mm Lock Washers
6	8mm Plastic Retainers	12	6mm Hex Nuts

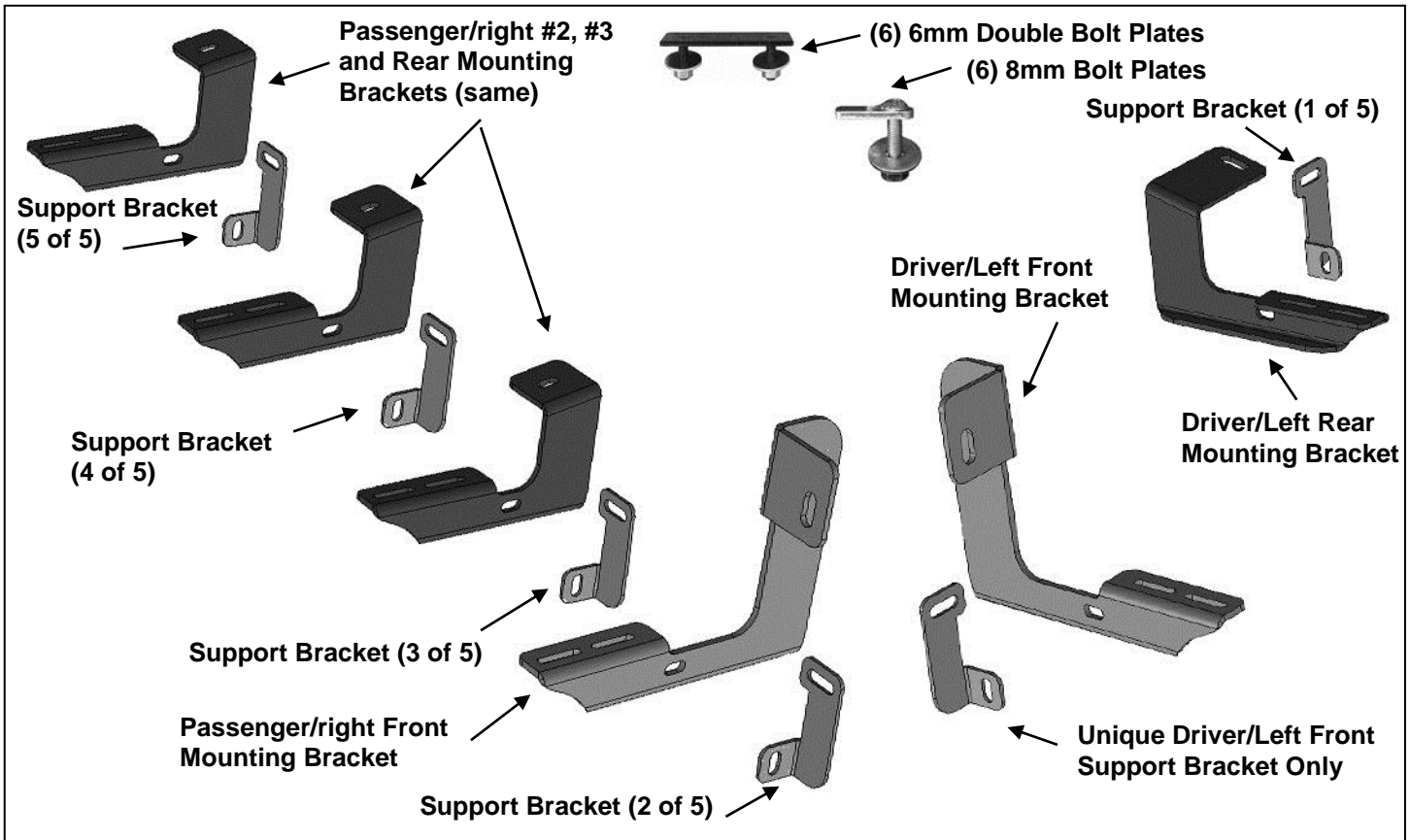

**PROCEDURE:**

**REMOVE CONTENTS FROM BOX. VERIFY ALL PARTS ARE PRESENT. READ INSTRUCTIONS CAREFULLY BEFORE STARTING INSTALLATION. DRILLING IS REQUIRED. ASSISTANCE IS RECOMMENDED.**

1. Start the installation under the driver side of the vehicle. Locate the factory hole in the side of the inner body panel, **(Figures 1 & 3)**. **IMPORTANT:** Hole may be covered with rubber plug, sealing tape and/or heavy undercoating. Remove excess undercoating from all mounting locations so that Brackets will install flat against body panel and pinch weld.
2. Select (1) 8mm Bolt Plate and (1) 8mm Plastic Retainer, **(Figure 2)**. Thread the Retainer part way onto the Bolt Plate. Insert the Bolt Plate into the hole and tighten the Retainer against the body panel, **(Figure 3)**. **IMPORTANT:** The Plastic Retainer is designed to prevent the Bolt Plate from falling into the body panel and to aid in Bracket installation.
3. Select the driver/left front Mounting Bracket. Attach the Bracket to the Bolt Plate with (1) 8mm x 28mm Large Flat Washer, (1) 8mm Lock Washer and (1) 8mm Hex Nut, **(Figure 4)**. Leave hardware loose at this time

4. Select the unique driver/left front Support Bracket, **(Figure 5)**. Attach the Support Bracket to the front of the Mounting Bracket with (1) 8mm x 25mm Hex Bolt, (2) 8mm x 16mm Small Flat Washers and (1) 8mm Nylon Lock Nut, **(Figure 6)**. Line up the top of the Support Bracket with the outside of the pinch weld. Leave hardware loose at this time.
5. Move to the driver side rear mounting location. Locate the factory hole in the bottom of the floor panel, **(Figure 7)**. Repeat **Steps 1—3** to attach the driver/left rear Bracket to the 8mm Bolt Plate, **(Figure 8)**.
6. Select (1) of the (5) identical Support Brackets, **(Figure 9)**. Attach the Support Bracket to the back of the rear Mounting Bracket with (1) 8mm x 25mm Hex Bolt, (2) 8mm x 16mm Small Flat Washers and (1) 8mm Nylon Lock Nut, **(Figure 10)**. Line up the top of the Support Bracket with the outside of the pinch weld. Leave hardware loose at this time.
7. Carefully unwrap the Running Boards. Place the short driver side Running Board on top of the (2) Brackets. Select (2) 6mm Double Bolt Plates, **(Figure 11)**. Locate the channels in the bottom of the Running Board, **(Figure 12)**. Insert the Bolt Plates into the channels closest to the Brackets. Lift the Running Board up and guide the studs down through the Brackets.
8. Attach the Running Board to the Brackets with (4) 6mm Flat Washers, (4) 6mm Lock Washers and (4) 6mm Hex Nuts, **(Figure 13)**. **NOTE:** The Running Board is designed to fit close to the vehicle. It may be necessary to loosen the Bracket hardware and tilt the Brackets downward to insert the Running Board between the Brackets and the body. Do not tighten hardware at this time.
9. Level and adjust the Running Board and tighten the Bracket to Bolt Plate hardware only. Remove the Running Board. Adjust the Support Brackets as necessary to move the top of the Brackets up to touch the bend in the pinch weld. Mark the location of the (2) slots in the Support Brackets onto the outside of the pinch weld, **(Figure 14)**.
10. Use a 5/16" drill bit to drill (2) holes through the pinch weld for the front and rear Support Brackets. **NOTE:** Drill the holes as far away from the bottom edge of the pinch weld as possible. **IMPORTANT:** Do not drill through the welds in the pinch weld if possible.

**IMPORTANT!** Any cutting or drilling tool may break or shatter. Government regulations require safety glasses & equipment at all times when cutting or drilling.

11. Attach the top of the Support Brackets to the outside of the pinch weld with (2) 8mm x 25mm Hex Bolts, (4) 8mm x 16mm Small Flat Washers and (2) 8mm Nylon Lock Nuts, **(Figure 15)**. Reinstall the Running Board. Level, adjust and tighten all hardware.
12. Move to the passenger side of the vehicle, **(Figure 16)**. Repeat **Steps 1—3** to attach the passenger side front Bracket, **(Figures 17 & 18)**. Repeat **Step 6** to attach (1) of the (5) identical Support Brackets.
13. Continue to the #2 mounting location, **(Figure 19)**. Repeat **Steps 5 & 6** to attach the #2 Mounting Bracket, **(Figure 20)**. Repeat to install the #3 and #4 (rear) Brackets, **(Figures 21—23)**.
14. Select the long passenger side running board. Select (4) 6mm Double Bolt Plates, **(Figure 11)**. Locate the channels in the bottom of the Running Board, **(Figure 12)**. Insert the Bolt Plates into the channels closest to the Brackets. Lift the Running Board up and guide the studs through the Brackets.
15. Attach the Running Board to the Brackets with (8) 6mm Flat Washers, (8) 6mm Lock Washers and (8) 6mm Hex Nuts, **(Figures 22 & 23)**.
16. Level and adjust the Running Board and tighten the Bracket to Bolt Plate hardware only. Remove the Running Board. Adjust the Support Brackets as necessary to move the top of the Brackets up to touch the bend in the pinch weld. Mark the location of the slots in the (3) Support Brackets onto the outside of the pinch weld, **(Figures 20 & 21)**.
17. Repeat **Steps 10 & 11** to drill and attach the (4) Support Brackets to the pinch weld.
18. Reinstall the Running Board. Level and adjust and tighten all hardware.
19. Do periodic inspections to the installation to make sure that all hardware is secure and tight.

**To protect your investment**, wax this product after installing. Regular waxing is recommended to add a protective layer over the finish. Do not use any type of polish or wax that may contain abrasives that could damage the finish. Mild soap may be used also to clean the Running Board.

### Driver/left Side Installation Pictured

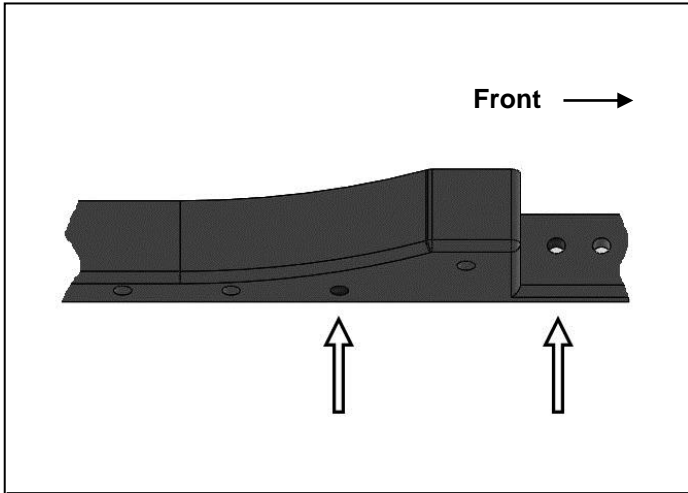

(Fig 1) Driver side front and rear mounting locations

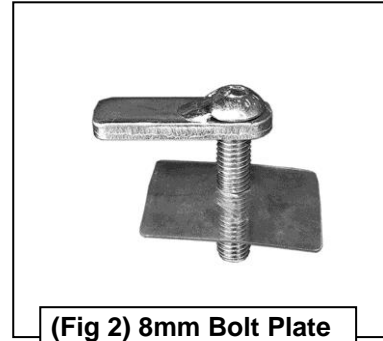

(Fig 2) 8mm Bolt Plate with Plastic Retainer

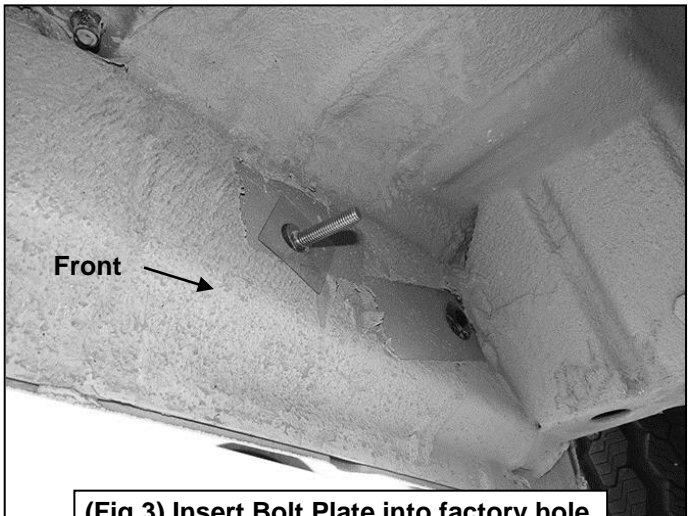

(Fig 3) Insert Bolt Plate into factory hole

8mm Large Flat Washer  
8mm Lock Washer  
8mm Hex Nut



(Fig 4) Driver side front Bracket pictured

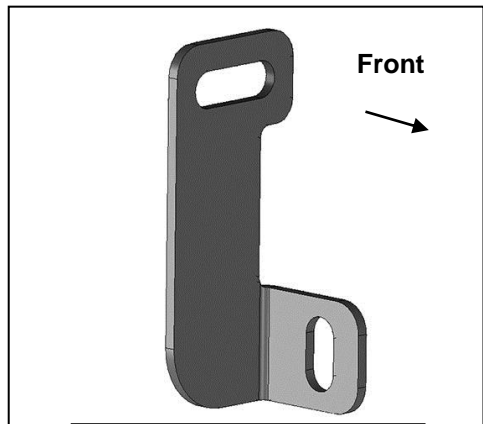

(Fig 5) Unique driver side front Support Bracket

**Driver/left Side Installation Pictured**

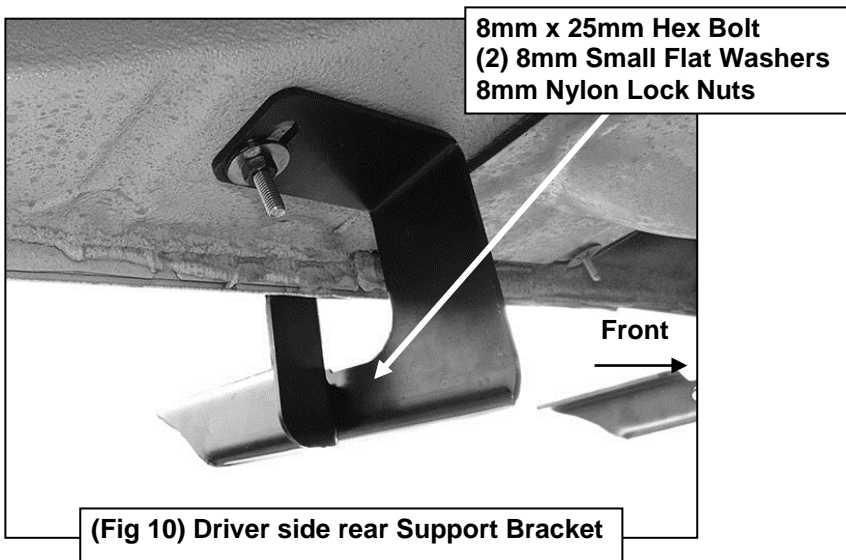
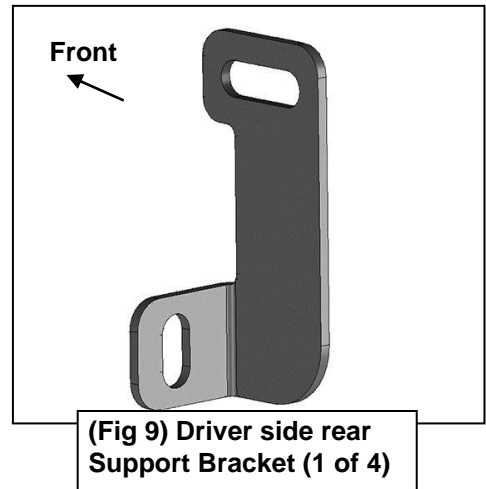
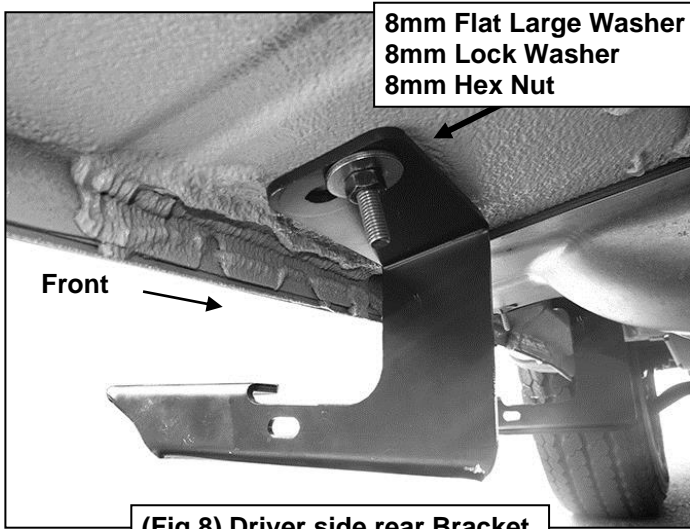
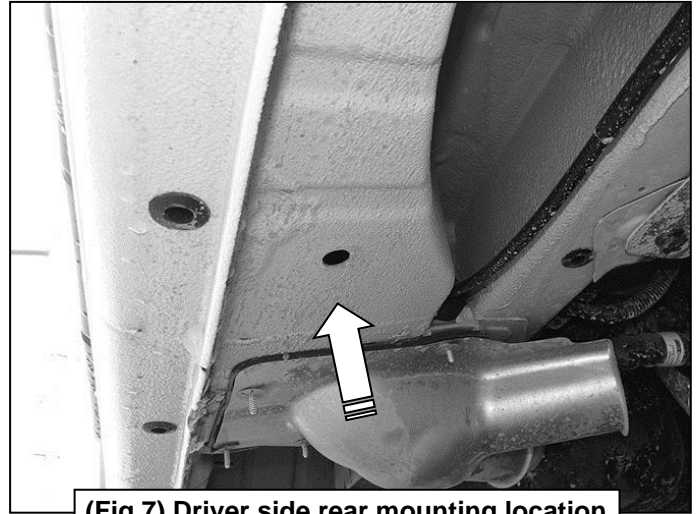
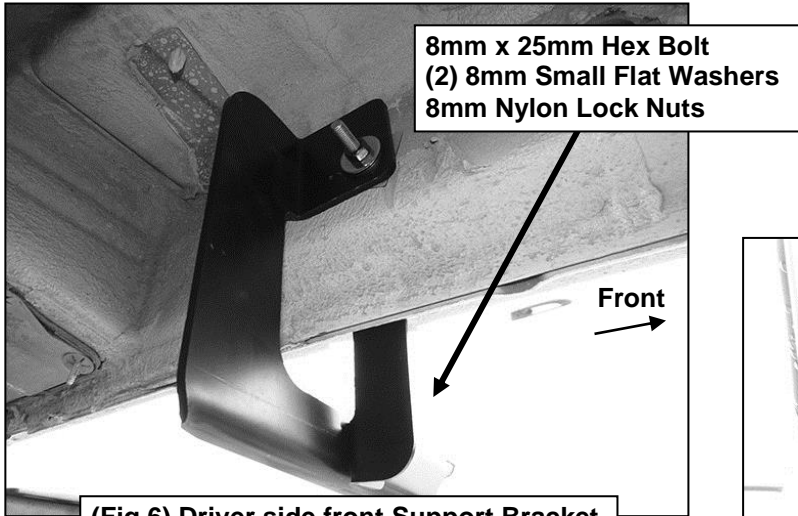

### Driver/left Side Installation Pictured

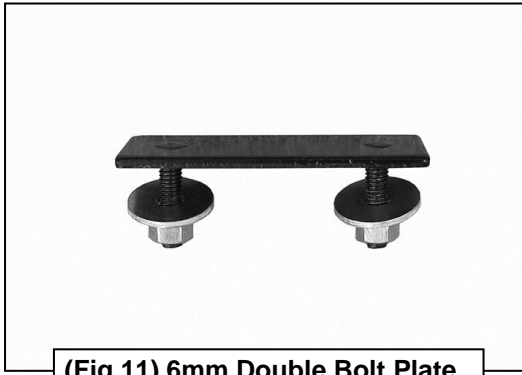

(Fig 11) 6mm Double Bolt Plate

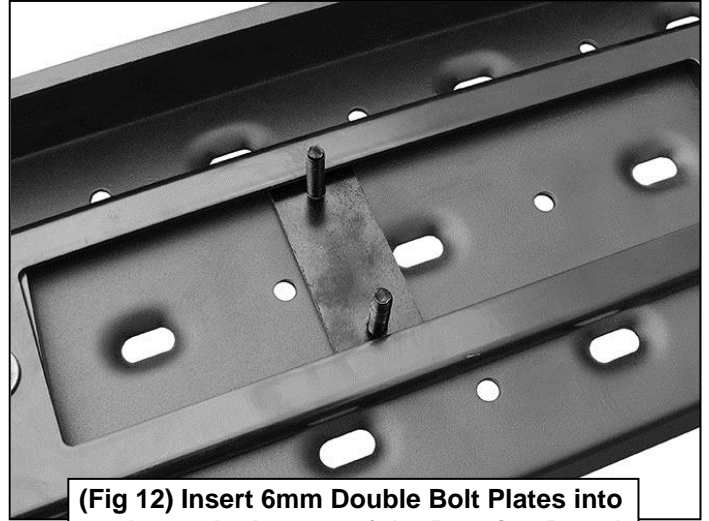

(Fig 12) Insert 6mm Double Bolt Plates into tracks on the bottom of the Running Board

- (2) 6mm Flat Washers
- (2) 6mm Lock Washers
- (2) 6mm Hex Nuts



(Fig 13) Attach Running Board to Brackets



Fig 14



Fig 15

Level and adjust the Running Board. Temporarily remove the running board. Mark and drill 5/16" hole through pinch weld for each Support Bracket

### Passenger/right Side Installation Pictured

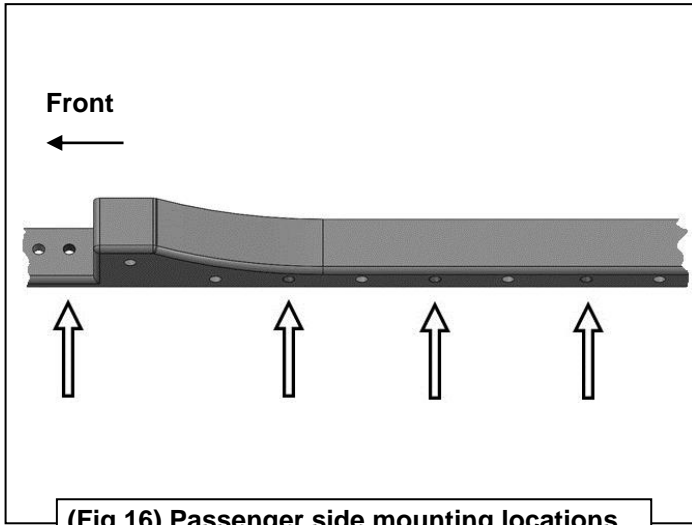

- (2) 8mm x 25mm Hex Bolts
- (2) 8mm Lock Washers
- (2) 8mm Flat Washers

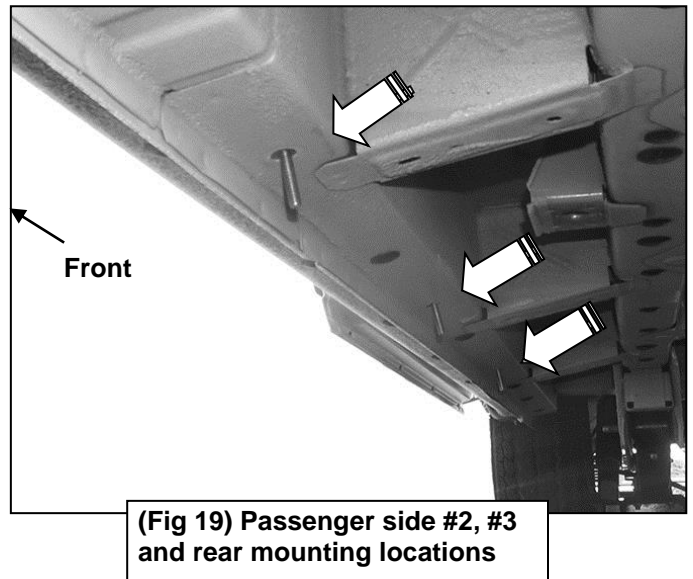
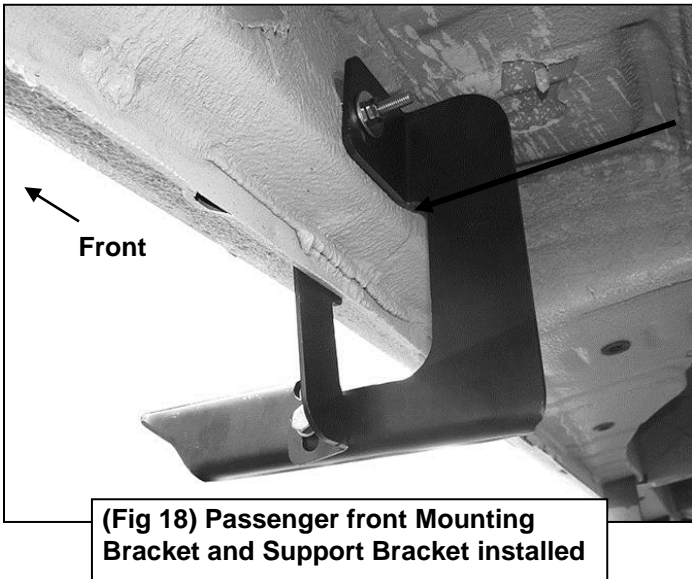
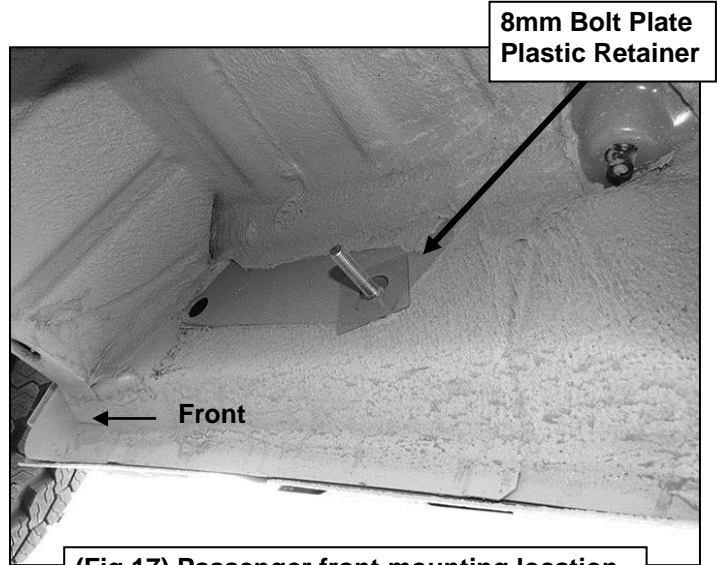



### Passenger/right Side Installation Pictured

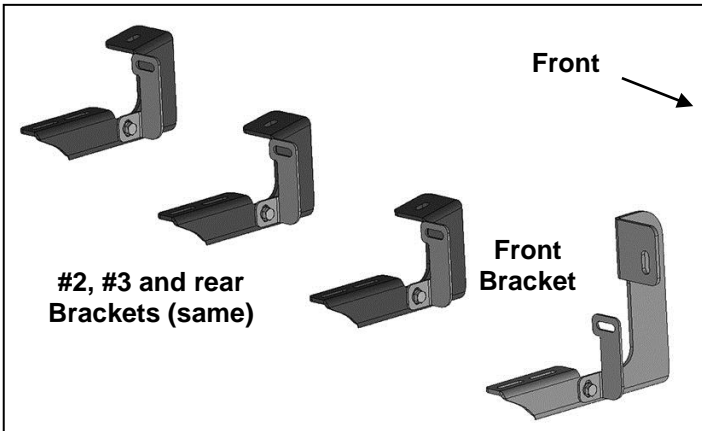

(Fig 21) Passenger side Bracket layout w-Support Brackets

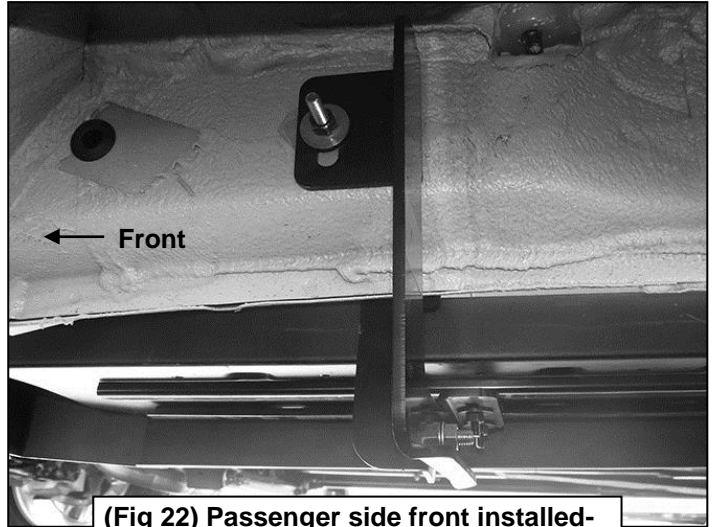

(Fig 22) Passenger side front installed-mark to drill through pinch weld



(Fig 23) Passenger side #2 and #3 Brackets installed-mark to drill through pinch weld



Complete Driver Side Installation



Complete Passenger Side Installation