

VIEWPOINT RUNNING BOARD BRACKETS FOR HONDA PILOT 16-17



**INSTALLATION INSTRUCTIONS**  
**VIEWPOINT RUNNING BOARD BRACKETS FOR HONDA PILOT 16-17**  
**PART # BR-HOPI16**

VIEWPOINT RUNNING BOARD BRACKETS FOR HONDA PILOT 16-17

**PARTS LIST:**

1	Driver side running board	12	8mm Lock Washer
1	Passenger side running board	12	8mm x 24mm x 2mm Flat Washers
2	Front Mounting Brackets (use for left or right)	12	6-1.0 x 20mm T-Bolts
2	Center Mounting Brackets (use for left or right)	12	6mm x 22mm OD x 2mm Flat Washer
2	Rear Mounting Brackets (use for left or right)	12	6mm Lock Washer
12	8-1.25mm x 25mm Hex Bolt	12	6-1.0mm Hex Nuts

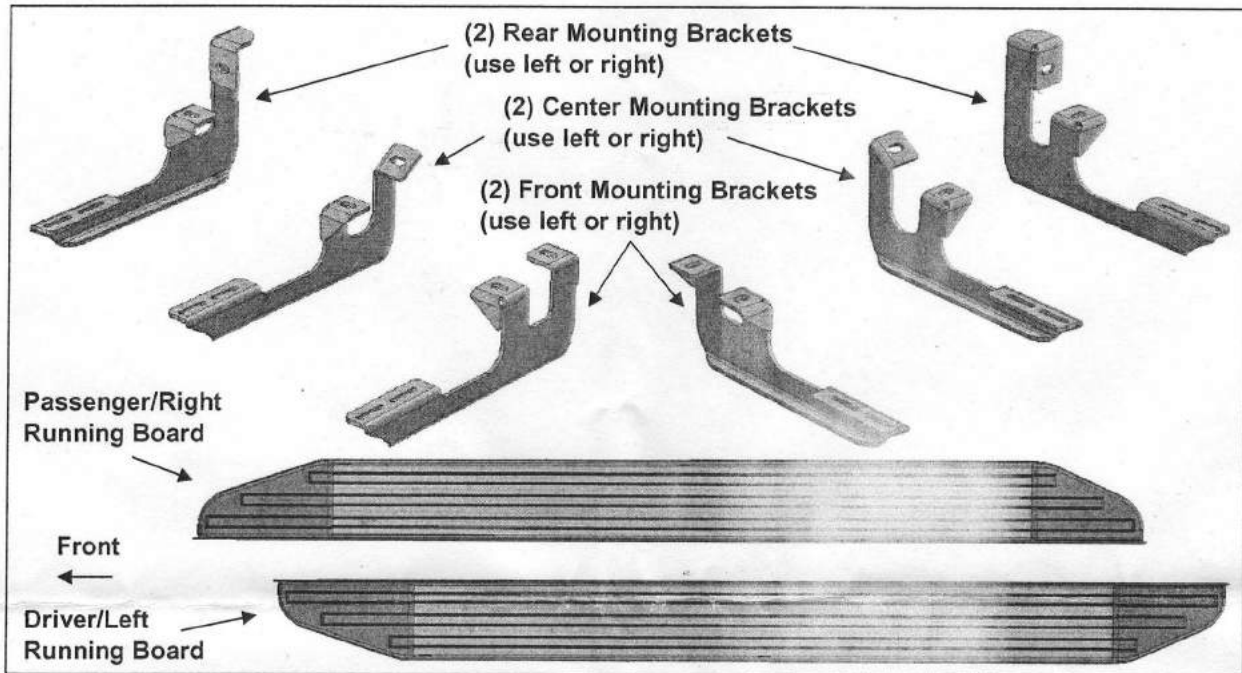

**PROCEDURE:**

**PROCEDURE:**

- 1. REMOVE CONTENTS FROM BOX. VERIFY ALL PARTS ARE PRESENT. READ INSTRUCTIONS CAREFULLY BEFORE STARTING INSTALLATION.**
- Starting on the driver/left side front of the vehicle, locate the two factory 8mm threaded holes located in the bottom of the floor panel, (Figure 1). **NOTE:** Brackets install in the factory running board mounting locations. Threaded holes may be covered with insulation. Clean mounting locations as required for proper Bracket installation.
- Select (1) Front Mounting Bracket, (Figure 2). **NOTE:** Brackets will fit left or right side. Attach the Bracket to the two threaded holes with (2) 8mm x 25mm Hex Bolts, (2) 8mm Lock Washers and (2) 8mm Flat Washers, (Figure 3). Do not tighten hardware at this time.
- Move to the center of the vehicle. Locate the two threaded holes in the bottom of the floor panel and body support panel, (Figure 4). Repeat Steps 2 & 3 to attach (1) Center Bracket, (Figures 5 & 6).
- Next, move to the driver/left rear of the vehicle. Locate the holes in the bottom and inner side of the floor panel, (Figure 7). Repeat Steps 2 & 3 to install (1) Rear Bracket, (Figures 8 & 9).
- Select the driver/left side Running Board. Locate the openings cut at the end of the slots on the bottom of the Running Board, (Figure 10). Insert (3) 6mm T-Bolts into each channel through the openings. Slide the T-Bolts into the approximate position in line with the (3) Brackets on the vehicle.

VIEWPOINT RUNNING BOARD BRACKETS FOR HONDA PILOT 16-17

7. Carefully position the Driver/Left Running Board onto the (3) Mounting Brackets. Slide the T-Bolts into position and through the slots in the Brackets. Attach the Board to the Brackets with (6) 6mm Flat Washers, (6) 6mm Lock washers and (6) 6mm Hex Nuts, **(Figure 11)**.  
**NOTE:** Temporarily loosen Brackets if necessary to fit Running Board between Brackets and vehicle. Do not tighten hardware at this time.
8. Level and adjust the Running Board and tighten all hardware.
9. Repeat **Steps 2—8** for the passenger/right Running Board installation.
10. Do periodic inspections to the installation to make sure that all hardware is secure and tight.

To protect your investment, wax this product after installing. Regular waxing is recommended to add a protective layer over the finish. Do not use any type of polish or wax that may contain abrasives that could damage the finish. For stainless steel: Aluminum polish may be used to polish small scratches and scuffs on the finish. Mild soap may be used also to clean the Running Board.

**Driver Side Installation Pictured**

Locate (2) factory  
8mm threaded holes

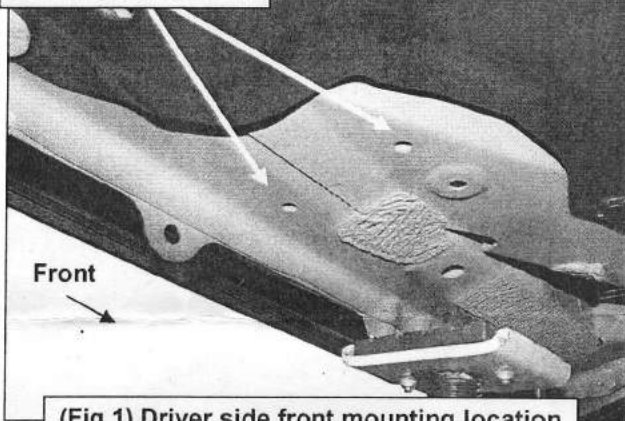

(Fig 1) Driver side front mounting location

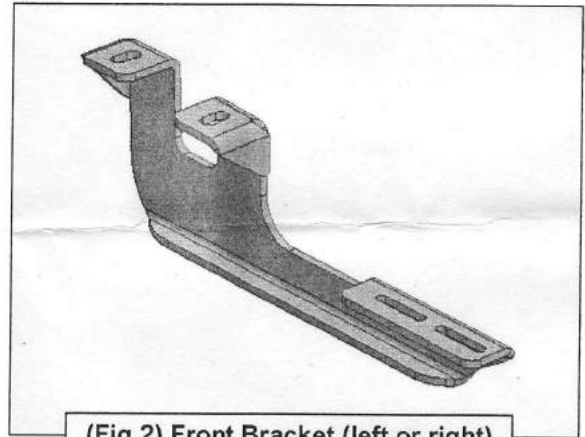

(Fig 2) Front Bracket (left or right)

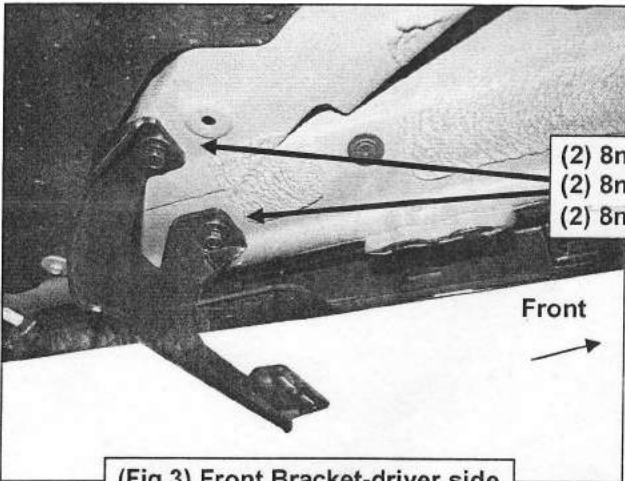

(2) 8mm x 25mm Hex Bolts  
(2) 8mm Lock Washers  
(2) 8mm Flat Washers

(Fig 3) Front Bracket-driver side

**Driver Side Installation Pictured**

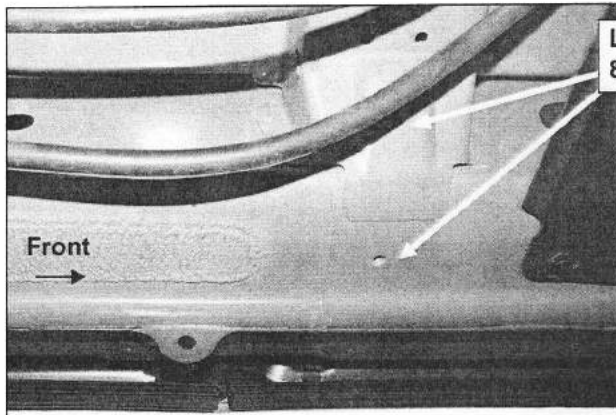

Locate (2) factory  
8mm threaded holes

(Fig 4) Driver side center mounting location

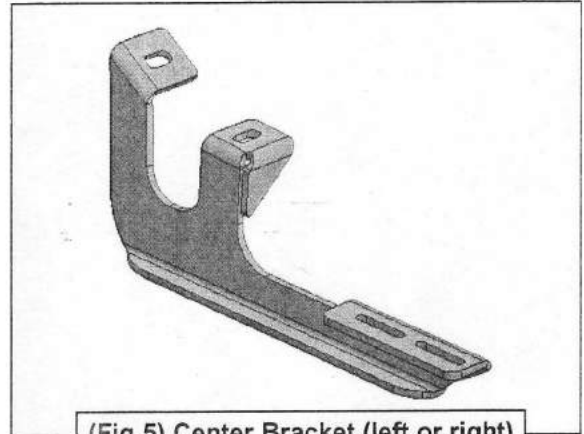

(Fig 5) Center Bracket (left or right)

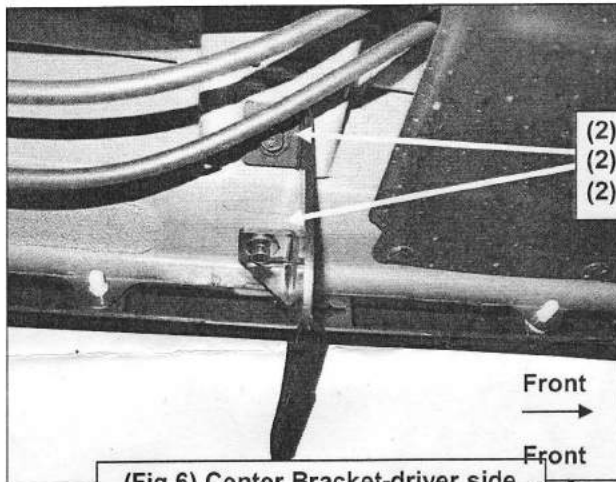

(2) 8mm x 25mm Hex Bolts  
(2) 8mm Lock Washers  
(2) 8mm Flat Washers

(Fig 6) Center Bracket-driver side

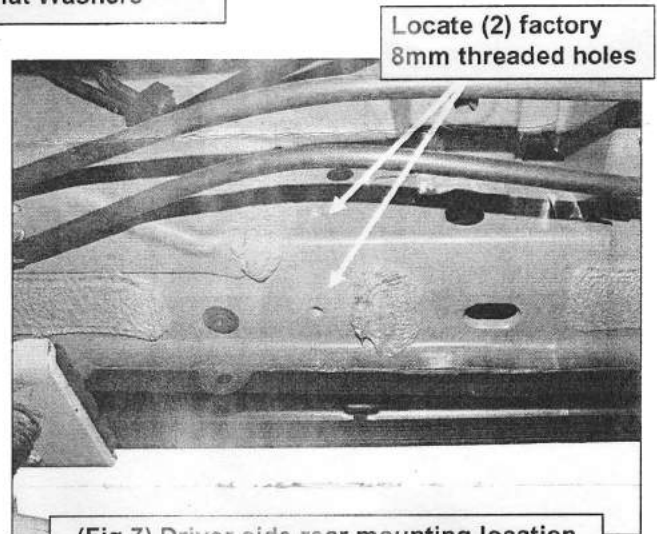

Locate (2) factory  
8mm threaded holes

(Fig 7) Driver side rear mounting location

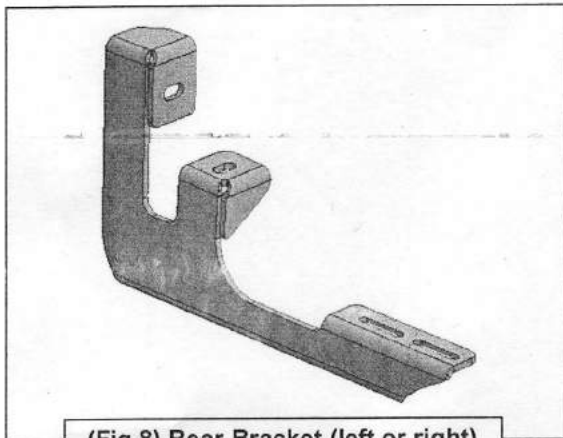

(Fig 8) Rear Bracket (left or right)

**Driver Side Installation Pictured**

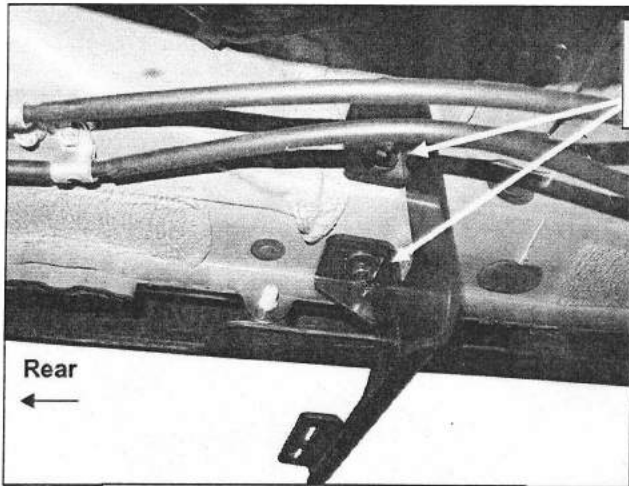

- (2) 8mm x 25mm Hex Bolts
- (2) 8mm Lock Washers
- (2) 8mm Flat Washers

(Fig 9) Rear Bracket-driver side

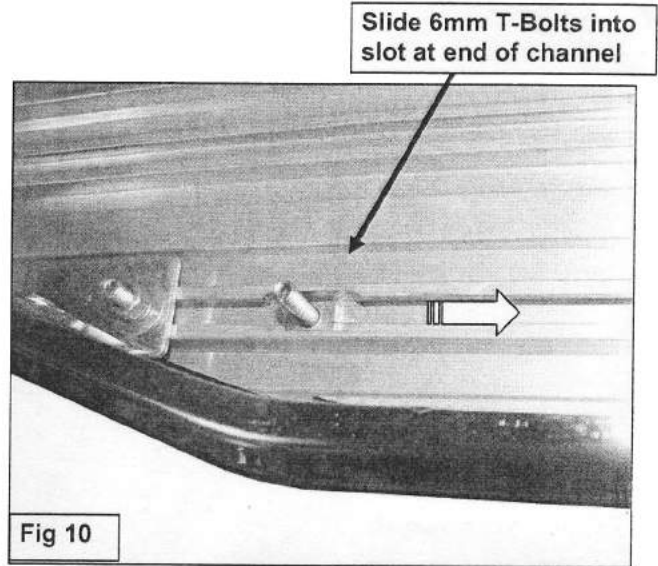

Slide 6mm T-Bolts into slot at end of channel

Fig 10

- (2) 6mm Flat Washers
- (2) 6mm Lock Washers
- (2) 6mm Hex Nuts

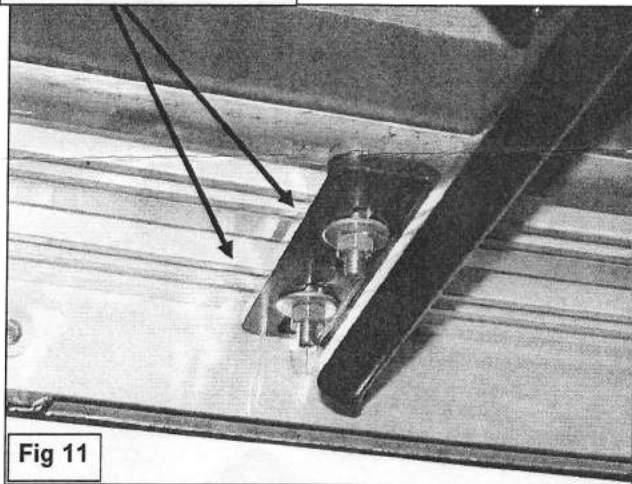
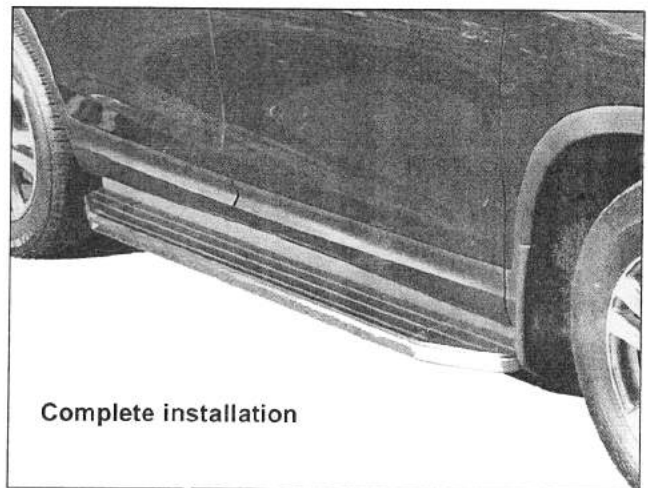

Fig 11



Complete installation