



# **INSTALLATION INSTRUCTIONS**

**PART#: AR-GMG379**

**ARMOUR RUNNING BOARDS**

**2015-2016 COLORADO/CANYON CREW CAB**

**PARTS LIST:**

2	Armour Running Boards	8	8-1.25mm x 30mm Hex Bolts
2	Driver/Left Front and Center Brackets	12	8mm x 24mm x 2mm Flat Washers
2	Passenger/Right Front and Center Brackets	12	8mm Lock Washers
1	Driver/Left Rear Mounting Bracket	4	8mm Hex Nuts
1	Passenger/Right Rear Mounting Bracket	6	6mm Double Bolt Plates
2	8mm x 60mm Long Bolt Plate (gold)	12	6mm x 22mm OD x 2mm Flat Washers
2	8mm x 50mm Short Bolt Plate (black)	12	6mm Lock Washers
4	8mm Plastic Retainers	12	6mm Hex Nuts
8	8-1.25mm Clip-On Nuts		

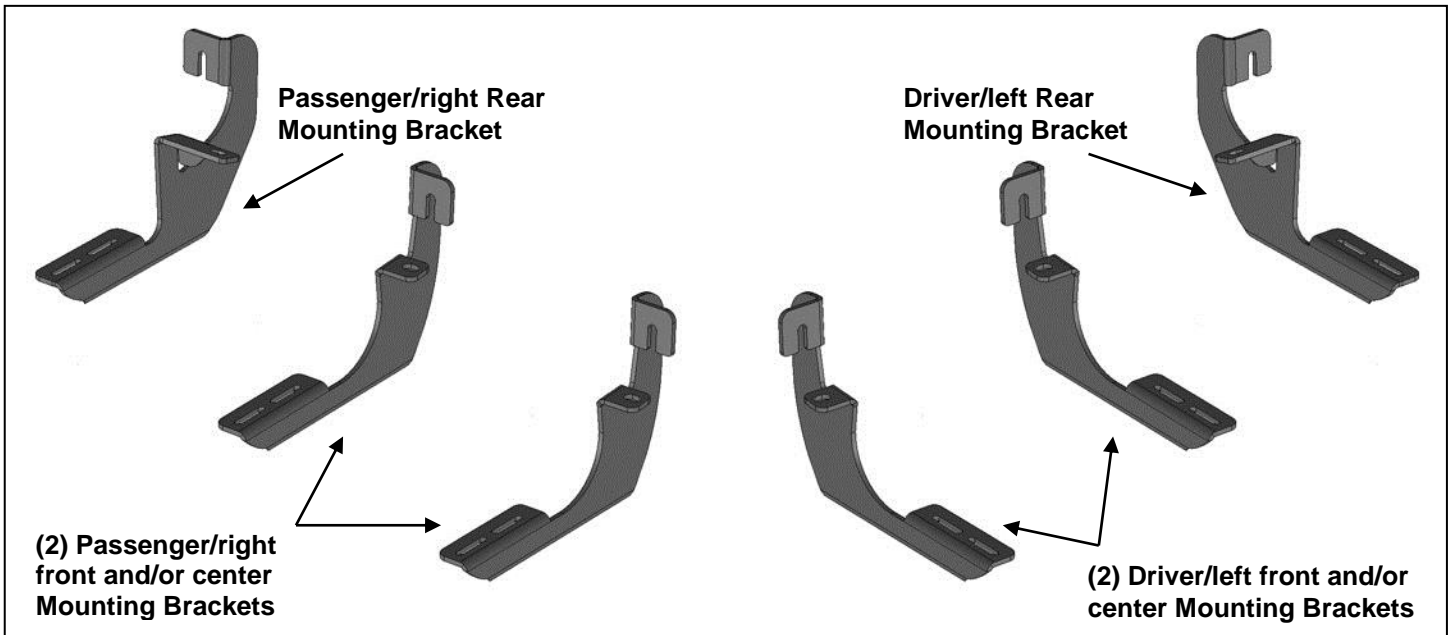

**PROCEDURE:**

**REMOVE CONTENTS FROM BOX. VERIFY ALL PARTS ARE PRESENT. READ INSTRUCTIONS CAREFULLY BEFORE STARTING INSTALLATION. ASSISTANCE IS RECOMMENDED.**

1. Start the installation under the passenger side of the vehicle. Locate the factory running board mounting locations along the bottom and inner side of the body panel, **(Figures 1 & 2)**. **NOTE:** It may help to hold a Bracket up in place to help determine the mounting holes to use along the bottom and inner side of the body.
2. Remove rubber plugs from the front location, **(Figure 2)**. Select (2) 8mm Clip Nuts. Slide each Clip Nut into the large hole and over the smaller hole next to it. Line up threaded nut on the Clip Nut with smaller hole in body panel, **(Figure 3)**.
3. Select (1) passenger side front and/or center Mounting Bracket, **(Figure 4)**. Attach the Bracket to the (2) Clip Nuts with (2) 8mm Hex Bolts, (2) 8mm Lock Washers and (2) 8mm Flat Washers, **(Figure 5)**. Snug but do not fully tighten the hardware.
4. Move to the next mounting location along the body, **(Figures 1 & 2)**. Repeat **Steps 1—3** to install the passenger side center Bracket, **(Figure 5)**.
5. Next, locate the rear mounting location toward the back of the cab, **(Figure 6)**. Remove the rubber plug from the bottom of the outer body panel. Select (1) 8mm x 50mm Short Bolt Plate, (black), and (1) 8mm Plastic Retainer, **(Figure 7)**. Partially thread the Retainer onto the Bolt Plate. Insert the Bolt Plate into the hole in the bottom of the body panel, **(Figures 8—10)**. Tighten the Retainer against the panel to hold the Bolt Plate in position.
6. Next, remove the rubber plug from the inner body panel, **(Figure 6)**. If necessary, hold the passenger side rear Mounting Bracket up in position to help identify the correct mounting location. Select (1) 8mm x 60mm Long Bolt Plate (gold), and 8mm Plastic Retainer, **(Figure 7)**. Repeat **Step 5** to install the Bolt Plate in the hole in the inner body panel, **(Figures 9 & 10)**.

7. Select the passenger side rear Mounting Bracket, **(Figure 10)**. Attach the Bracket to the (2) Bolt Plates with (2) 8mm Flat Washers, (2) 8mm Lock Washers and (2) 8mm Hex Nuts, **(Figures 10, 11A & 11B)**. **NOTE:** Bracket must install flat against inner sheet-metal, remove sealant as necessary. Do not fully tighten hardware.
8. Once all (3) Brackets have been fully installed, select the passenger side Running Board.
9. Place the Running Board on top of the Brackets. Locate the channels in the bottom of the Running Board. Select (3) 6mm Double Bolt Plates. Insert the Bolt Plates into the channels in the bottom of the Running Board closest to the Brackets, **(Figure 12)**. Lift the Running Board up and guide the studs down through the Brackets.
10. Attach the Running Board to the Brackets with (6) 6mm Flat Washers, (6) 6mm Lock Washers and (6) 6mm Hex Nuts, **(Figures 13 & 14)**. **NOTE:** The Running Board is designed to fit close to the vehicle. It may be necessary to loosen the Bracket hardware slightly and tilt the Brackets downward to insert the Running Board between the Brackets and the body.
11. Slide the Running Board forward or back and in/out as desired. **IMPORTANT:** Do not allow the front of the Running Board to come in contact with front splash guards if equipped. Level and adjust the Running Board as necessary and fully tighten all hardware.
12. Repeat **Steps 1—11** for driver side Running Board installation.
13. Do periodic inspections to the installation to make sure that all hardware is secure and tight.

**To protect your investment**, wax this product after installing. Regular waxing is recommended to add a protective layer over the finish. Do not use any type of polish or wax that may contain abrasives that could damage the finish.  
**For gloss black finishes:** Mild soap may be used to clean the Running Board.

### Passenger/right Side Installation Pictured

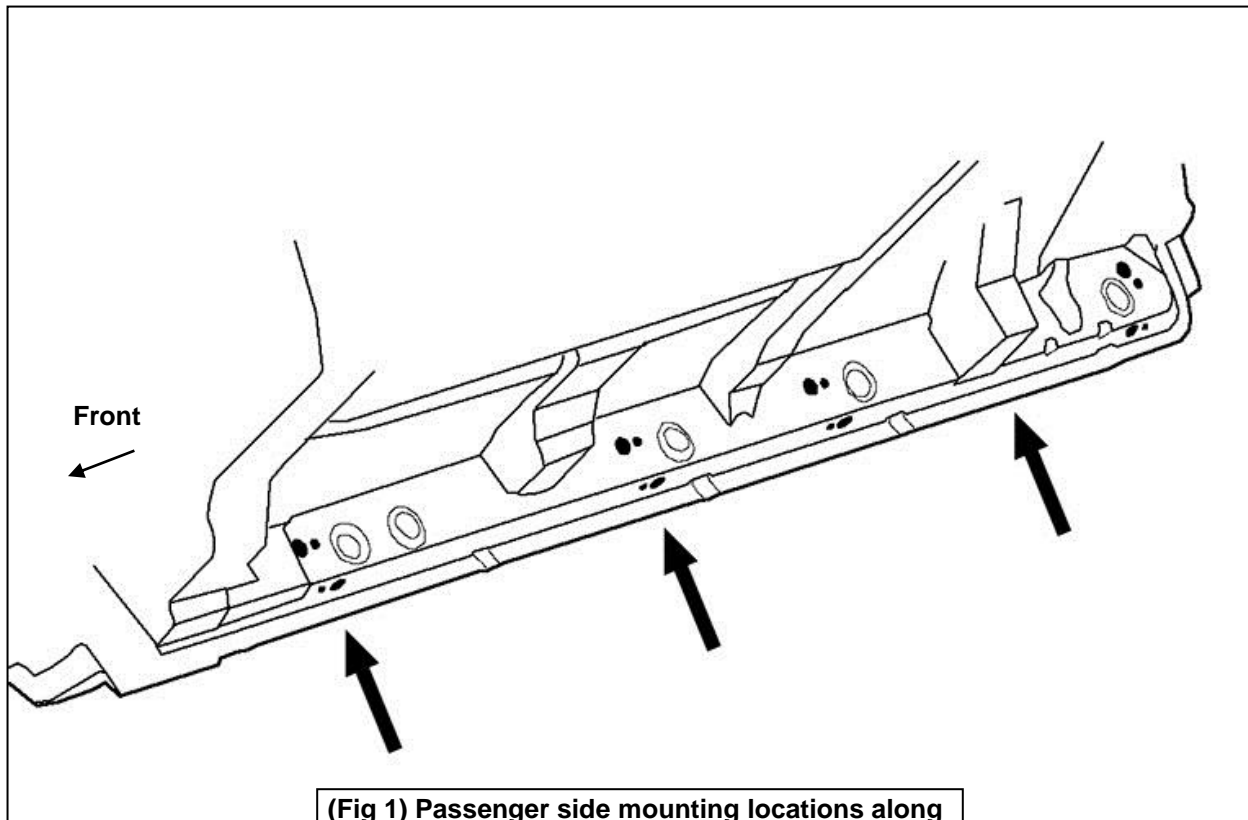

**(Fig 1) Passenger side mounting locations along bottom and back of body panel illustrated**

### Passenger/right Side Installation Pictured

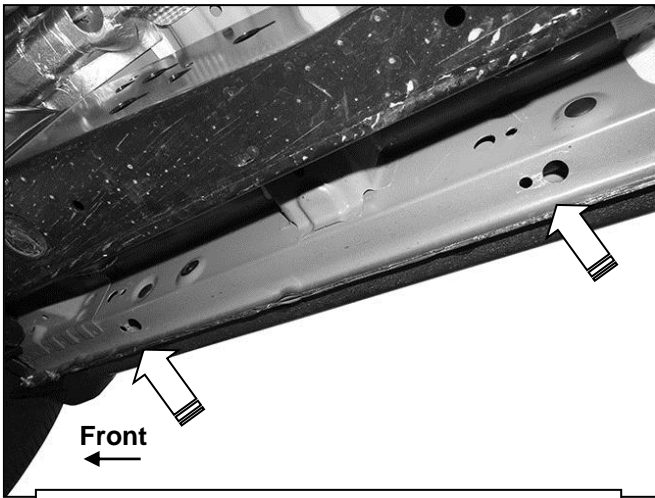

(Fig 2) Remove rubber plugs from front and center mounting locations (arrows)

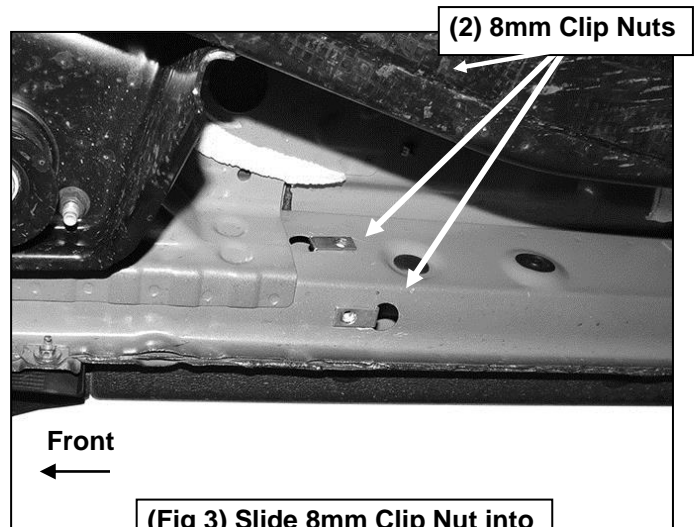

(Fig 3) Slide 8mm Clip Nut into large hole and over small hole

- (2) 8mm x 30mm Hex Bolts
- (2) 8mm Lock Washers
- (2) 8mm Flat Washers

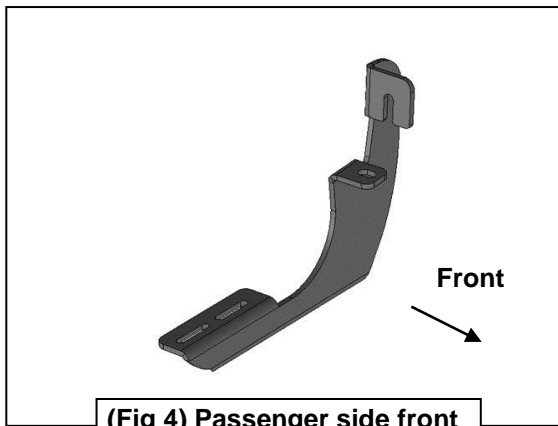

(Fig 4) Passenger side front and/or center Bracket



(Fig 5) Attach Bracket to Clip Nuts (Passenger side center Bracket pictured)

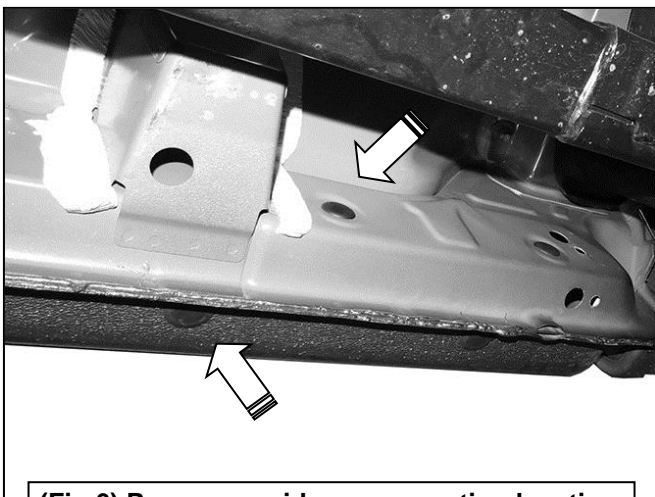

(Fig 6) Passenger side rear mounting location

### Passenger/right Side Installation Pictured

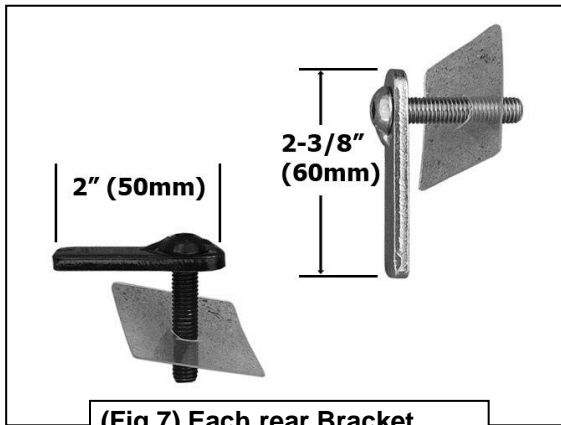

(Fig 7) Each rear Bracket requires (1) each Bolt Plates

8mm x 60mm Long Bolt Plate (gold)  
8mm Plastic Retainer

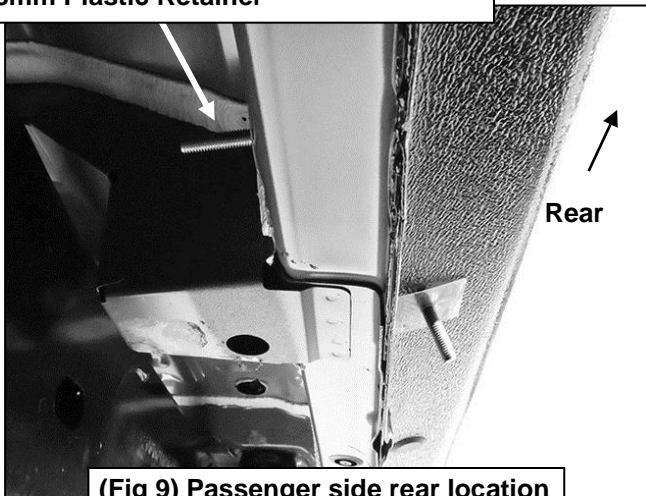

(Fig 9) Passenger side rear location with Bolt Plates installed

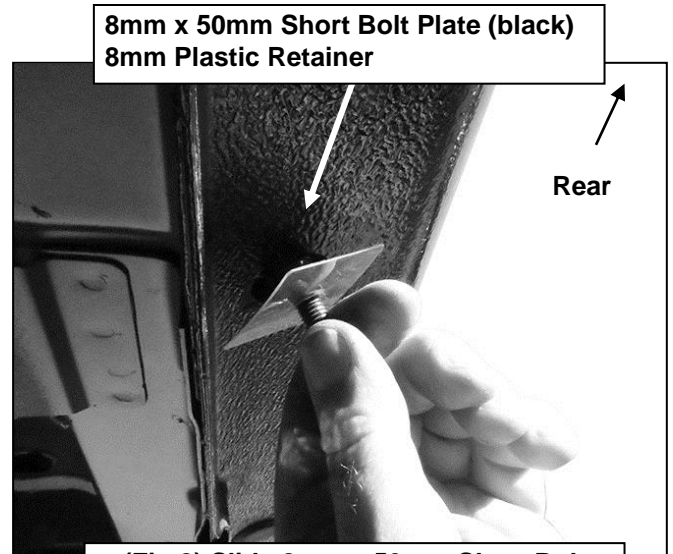

8mm x 50mm Short Bolt Plate (black)  
8mm Plastic Retainer

(Fig 8) Slide 8mm x 50mm Short Bolt Plate into outer hole in body panel

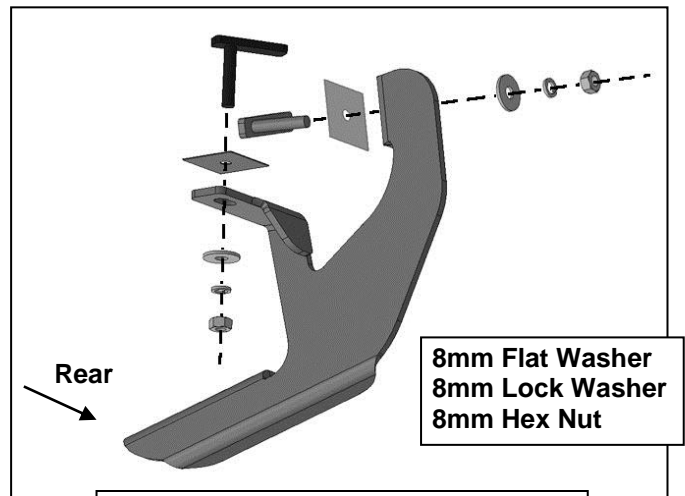

8mm Flat Washer  
8mm Lock Washer  
8mm Hex Nut

(Fig 10) Passenger side rear Bracket

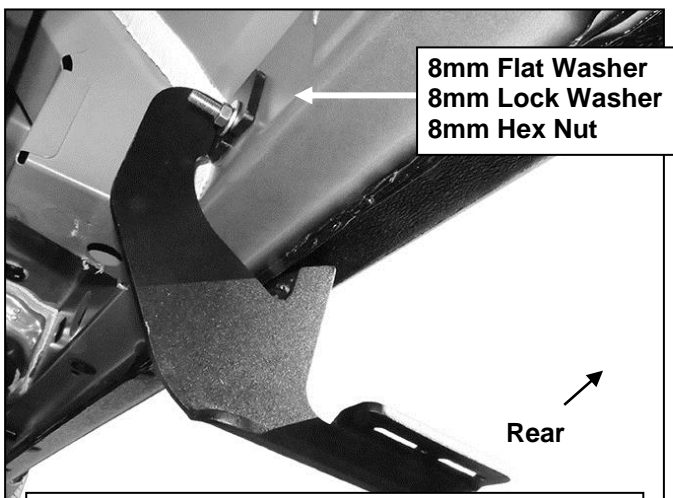

8mm Flat Washer  
8mm Lock Washer  
8mm Hex Nut

(Fig 11A) Passenger side rear Bracket installed

### Passenger/right Side Installation Pictured

