



INSTALLATION INSTRUCTIONS

**ARMOUR REAR BUMPER FOR
17-18 FORD F250/350 SUPERDUTY
PART#ARB-F217**

**ARMOUR REAR BUMPER
2017-18 FORD SUPER DUTY F250-350**

PARTS LIST:

1	ARMOUR Rear Bumper Assembly	4	15.5mm x 25mm x 2mm Foam Washers
2	Plastic Plugs for license plate mount	1	Sensor Covers Kit
4	Sensor Plugs	8	4mm x 10mm Socket Head Screws
4	Retaining Rings	1	4mm Wrench
4	20mm x 10mm Foam Spacers	1	2.5mm Wrench

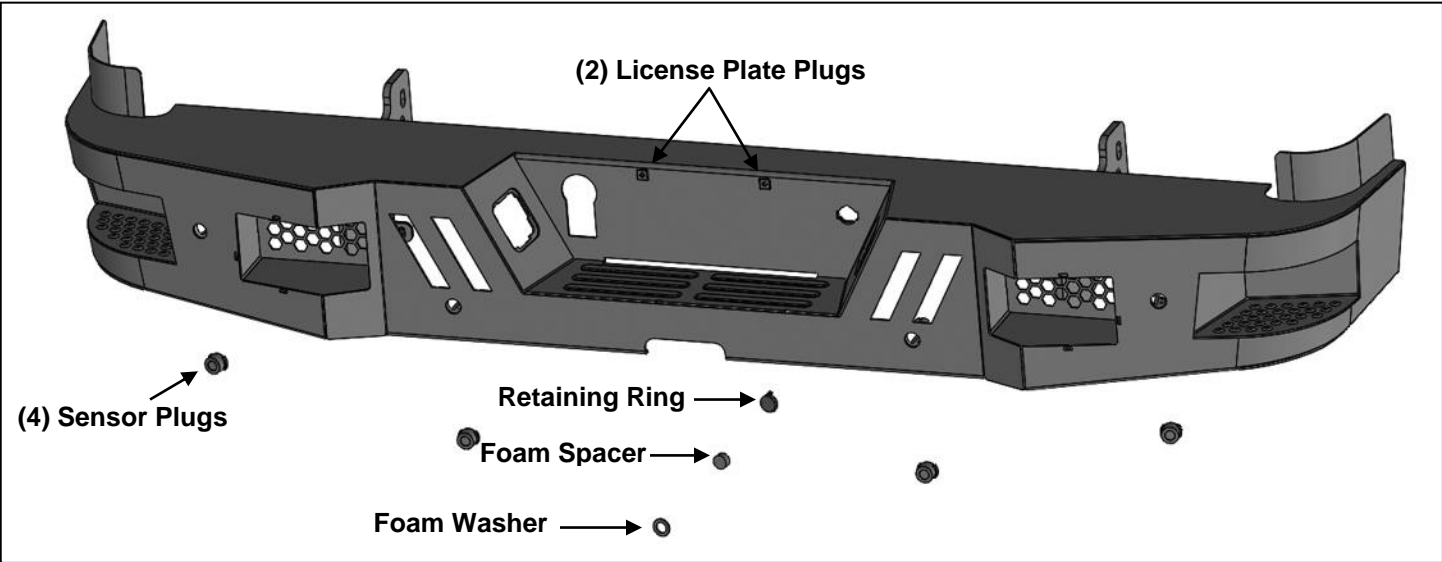

PROCEDURE:

REMOVE CONTENTS FROM BOX. VERIFY ALL PARTS ARE PRESENT. READ INSTRUCTIONS CAREFULLY BEFORE STARTING INSTALLATION. BUMPER IS HEAVY, ASSISTANCE IS HIGHLY RECOMMENDED TO AVOID POSSIBLE INJURY OR DAMAGE TO THE VEHICLE.

1. Remove the license plate and bracket. On models with back up sensors, unplug the harness leading to the bumper and sensors. Unplug the factory license plate lights remove them from the bumper. Unplug the trailer harness plug from the back of the bumper. Remove the outer plug from the bumper. Move the wiring harness away from the bumper, **(Figure 1)**.
2. Place blocks or jack stands under the bumper to support it during mounting bolt removal. Once the bumper has been safely supported, remove the (2) large hex nuts per side attaching the bumper to the brackets attached to the frame, **(Figure 2)**. **WARNING!** Assistance is required to hold the bumper in place during hardware removal to prevent the bumper from falling.
3. Once the bumper has been moved away from the vehicle, remove the bumper brackets from the frame, **(Figures 3 & 4)**. **NOTE:** Do not remove the 90-degree support brackets attached to the top of the receiver hitch, **(Figure 5)**.
4. **LED light installation at ends of bumper**, (lights sold separately).
 - a. Insert light into opening and up to mounting slots. Check for clearance between front and back of light. If necessary, remove the screen from the back of the opening for additional clearance or access to light, **(Figure 6)**.
 - b. Follow the light manufacturer's instructions to attach (1) light to the center slot or (2) lights to the inner and outer slots in the top of the light opening.
 - c. Repeat the above steps for passenger side light installation.
 - d. Follow light manufacturer's instructions to properly wire the light.
5. **NOTE:** Sensors, (if equipped), must be installed onto the back of the Bumper before installing the Bumper to the vehicle.

Models without bumper sensors:

- a. Select the included (4) Rubber Plugs.
- b. From behind bumper, push plugs into sensor mounting holes.

Models with bumper mounted sensors:

**ARMOUR REAR BUMPER
2017-18 FORD SUPER DUTY F250-350**

- a. Remove the small factory sealing washer from the sensor. Attach the provided larger (1) Foam Washer onto the front of the sensor, **(Figure 7)**.
 - b. Push the sensor in from the back of the Bumper until it is flush with the sensor sleeve. **NOTE:** Sensor tabs may need to be trimmed to fit sensor inside the sensor sleeve. Attach the adhesive side of (1) Foam Spacer to (1) Retaining Ring. Push the Retaining Ring into the sensor sleeve until it locks into the mounting holes, **(Figure 7)**.
 - c. Repeat the previous steps to install each sensor to the back of the Bumper.
6. With assistance, position the mounting plates on the back of the ARMOUR Bumper Assembly up to the outsides of the frame. Temporarily support the weight of the Bumper Assembly. **WARNING:** To avoid possible injury or damage to the vehicle, do not proceed until the Bumper is fully and safely supported.
 7. Line up the (4) holes in the passenger side mounting plate with the (2) holes in the side of the frame and the (2) holes in the support bracket on the hitch. Reuse the factory double bolt plates and hardware to attach the mounting plate to the frame and support bracket, **(Figure 8)**. Leave hardware loose. Repeat this Step to attach the driver side mounting plate.
 8. Slowly open the tail gate and check for clearance. Level and adjust the bumper as necessary and fully tighten all hardware.
 9. Select the (2) factory license plate lights. Push the lights into the holes in the Bumper, **(Figure 9)**.
 10. Install the trailer plug into the opening in the bumper. Reinstall the access hole lock for the spare tire, **(Figure 10)**.
 11. Reattach the wire harness running to the license plate lights and trailer plug.
 12. Use the included (2) push-in plastic nuts to attach the license plate to the (2) holes in the Bumper Assembly, **(Figure 10)**.
 13. Do periodic inspections to the installation to make sure that all hardware is secure and tight.

To protect your investment, wax this product after installing. Regular waxing is recommended to add a protective layer over the finish. Do not use any type of polish or wax that may contain abrasives that could damage the finish. Mild soap may be used to clean the ARMOUR Bumper assembly.

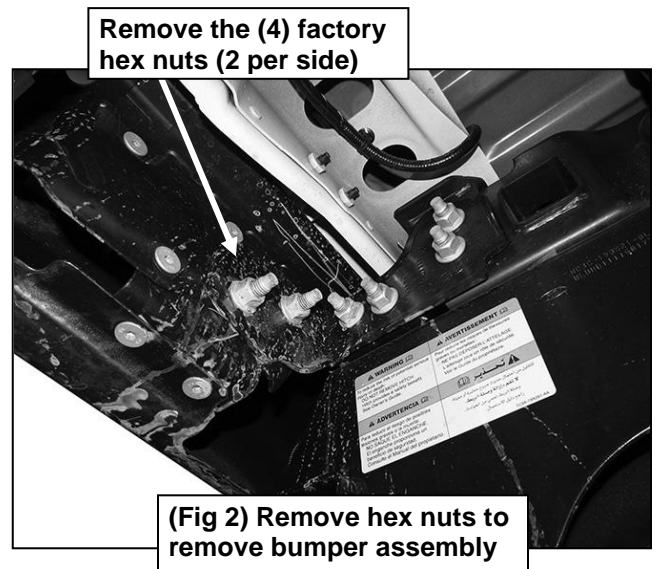
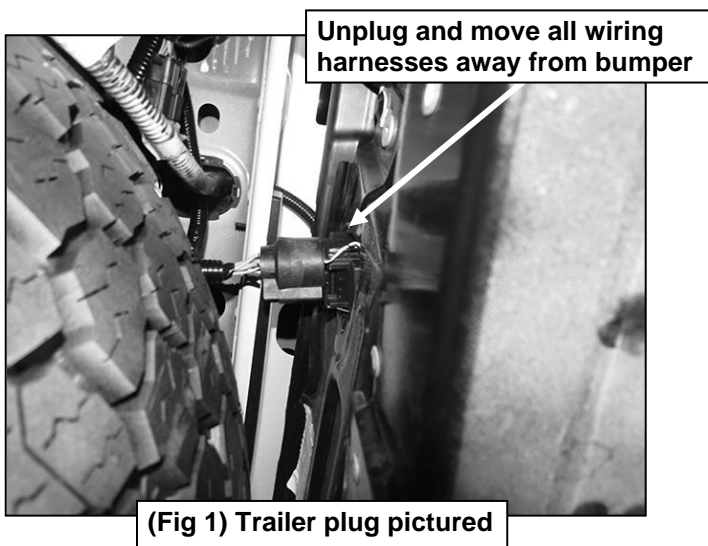

WARNING! Do not remove bumper bolts unless the bumper is properly supported on blocks or stands or the bumper may fall.

**ARMOUR REAR BUMPER
2017-18 FORD SUPER DUTY F250-350**

Passenger/right Side Installation Pictured

WARNING! Do not crawl under bumper unless the bumper is properly supported on blocks or stands or the bumper may fall.

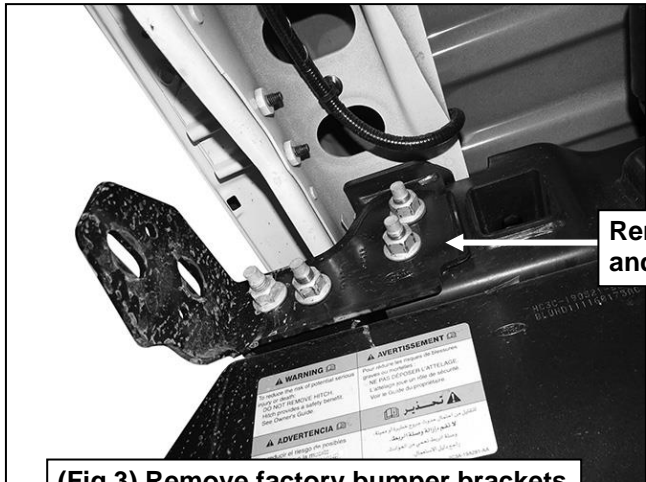

Remove bumper bracket and double bolt plates

(Fig 3) Remove factory bumper brackets

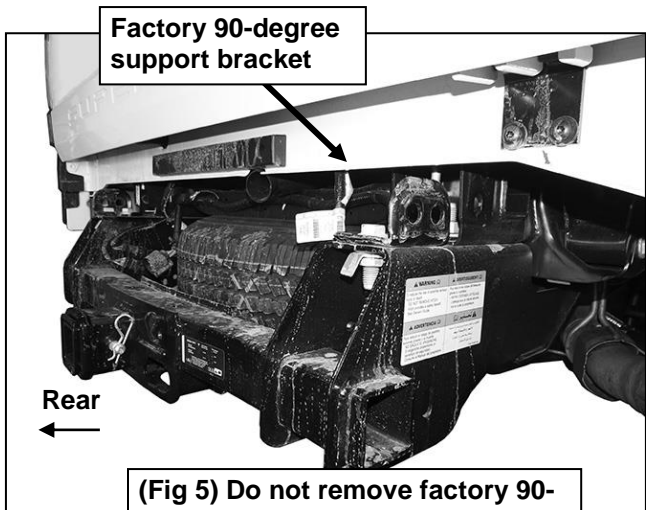

Factory 90-degree support bracket

(Fig 5) Do not remove factory 90-degree support Brackets

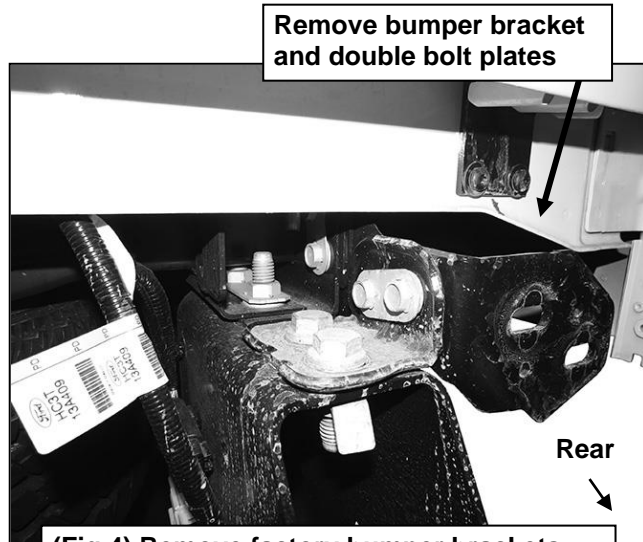

Remove bumper bracket and double bolt plates

(Fig 4) Remove factory bumper brackets, do not remove 90-degree support bracket

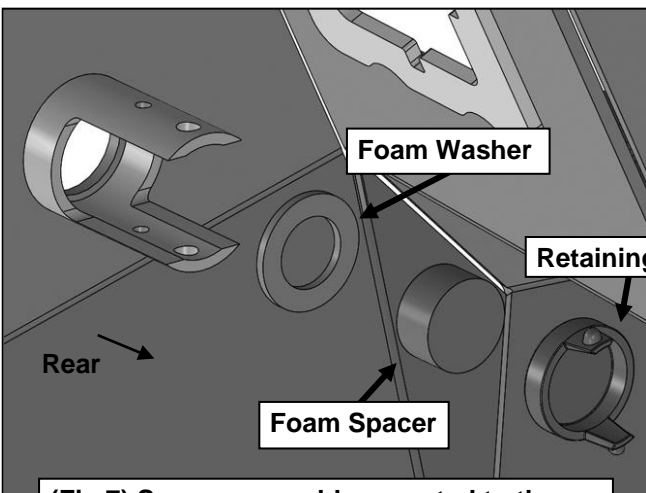

Foam Washer

Retaining Ring

Foam Spacer

(Fig 7) Sensor assembly mounted to the sensor sleeve on the back of the Bumper

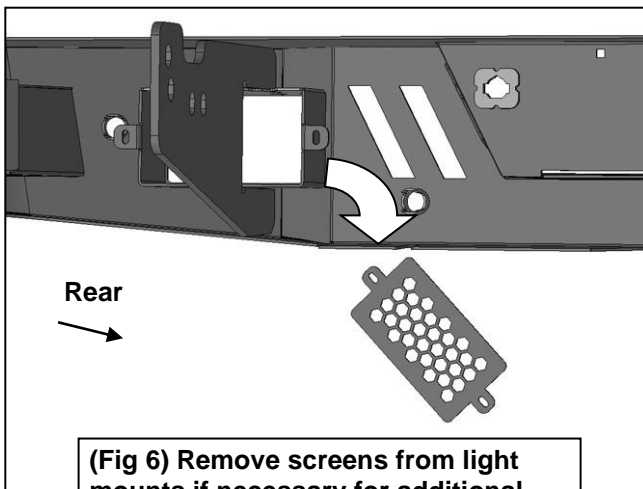

(Fig 6) Remove screens from light mounts if necessary for additional clearance around or access to lights

**ARMOUR REAR BUMPER
2017-18 FORD SUPER DUTY F250-350**

Passenger/right Side Installation Pictured

**Reuse factory double
bolt plate and hardware**

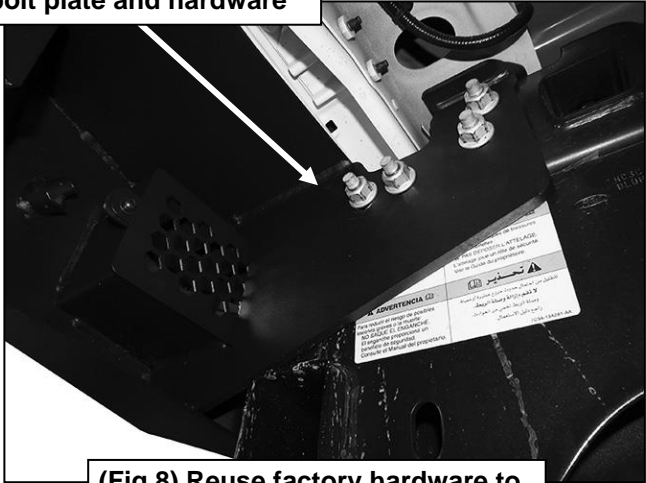

**(Fig 8) Reuse factory hardware to
attach mounting plate to side of
bumper (passenger side pictured)**

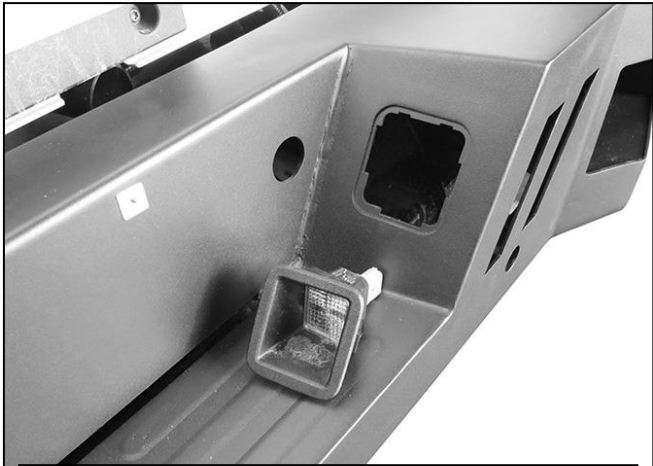

(Fig 9) Push license plate lights into openings

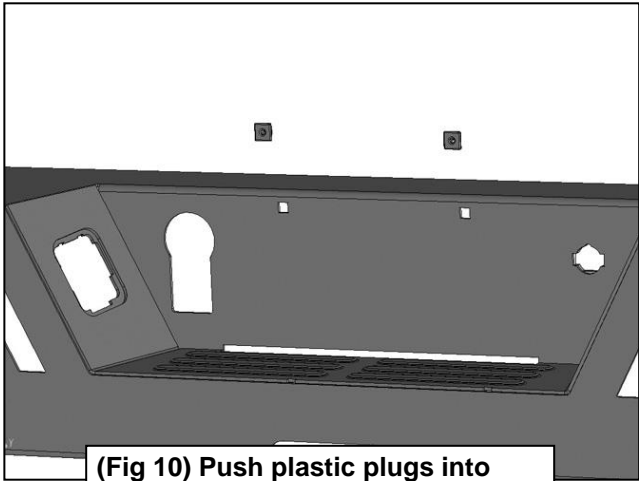

**(Fig 10) Push plastic plugs into
holes in Bumper for license plate**



Complete Installation