



INSTALLATION INSTRUCTIONS

ARMOUR FRONT BUMPER FOR

2013-16 DODGE RAM 1500

PART # AFB-RA13

PARTS LIST:

1	ARMOUR Front Bumper Assembly	16	10mm x 27mm OD x 3mm Flat Washers
1	Driver/left Frame Mounting Bracket	8	10mm Lock Washers
1	Passenger/right Frame Mounting Bracket	8	10mm Hex Nuts
1	Driver/left Top Corner Filler Panel	2	8-1.25mm x 25mm Hex Bolts
1	Passenger/right Top Corner Filler Panel	2	8-1.25mm x 16mm Hex Bolts (LED light bar)
1	Driver/left "L" Bracket (center LED light)	6	8mm x 24mm Flat Washers
1	Passenger/right "L" Bracket (center LED light)	4	8mm Lock Washers
1	License Plate Bracket	2	8mm Hex Nuts
2	Plastic Plugs for license plate mount	6	6mm x 20mm Button Head Bolts
6	Sensor Hole Plugs	4	6mm x 18mm x 1.6mm Flat Washers
10	Nylon Wire Ties	4	6mm x 12mm OD x 1.5mm Flat Washers
6	12-1.75mm x 35mm Hex Bolt	4	6mm Lock Washers
12	12mm x 24mm OD x 2.5mm Flat Washers	2	6mm Nylon Lock Nuts
6	12mm Lock Washers	1	6mm Allen Wrench
6	12mm Hex Nuts	12	4mm x 10mm Button Head Bolts
8	10-1.5mm x 35mm Hex Bolts	1	4mm Allen Wrench

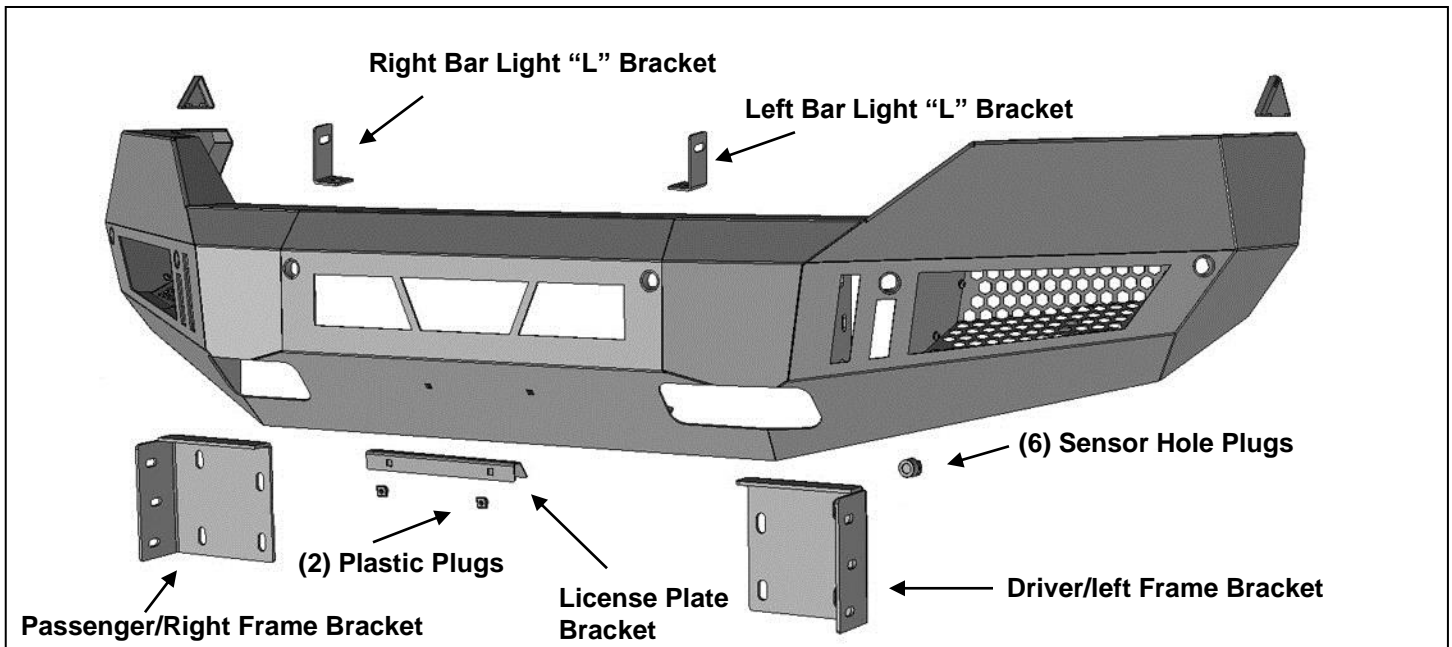

PROCEDURE:

REMOVE CONTENTS FROM BOX. VERIFY ALL PARTS ARE PRESENT. READ INSTRUCTIONS CAREFULLY BEFORE STARTING INSTALLATION. BUMPER IS HEAVY, ASSISTANCE IS HIGHLY RECOMMENDED TO AVOID POSSIBLE INJURY OR DAMAGE TO THE VEHICLE.

1. Remove the license plate and bracket. Remove lower air dam, (**Figure 1**). **NOTE:** Air dam is attached with many 2pc retaining clips. Pry up center of pin to release and remove clips.
2. On models with factory fog lights and/or sensors, unplug wiring harness, (**Figure 2**). Release the harness from the clips attached to the back of the bumper and move harness away.
3. Next, remove the plastic fascia fill panel between the headlights and the top of the bumper. **NOTE:** Release inner fender liner to access hardware attaching the ends of fascia panel to the bottom of the front fenders, (**Figures 3 & 4**).
4. Place blocks or jack stands under the front bumper to support it during mounting bolt removal. Once the bumper has been safely supported, remove the (3) hex nuts attaching each bumper bracket to the end of the frame, (**Figure 5**). **WARNING!** Assistance is required to hold the

bumper in place during hardware removal to prevent the bumper from falling. Slide the bumper assembly off of the tow hooks, (if equipped).

5. Next, remove the plastic inner support blocks from the bottom of the headlights, **(Figure 6)**.
6. Select the driver/left side Frame Mounting Bracket, **(Figure 7)**. **NOTE:** Holes in mounting flange on end of frame are two sizes (3-large, 1-small). Attach the Bracket to the end of the frame with (3) 12mm x 35mm Hex Bolts, (6) 12mm Flat Washers, (3) 12mm Lock Washers and (3) 12mm Hex Nuts. Use (1) 10mm x 35mm Hex Bolt, (2) 10mm Flat Washers, (1) 10mm Lock Washer and (1) 10mm Hex Nut to attach the Bracket to the smaller, top inner mounting hole in the bumper flange, **(Figures 7 & 8)**. Repeat Step to install the passenger/right Frame Bracket.
7. With assistance, position the ARMOUR Bumper Assembly up to the outside of the Frame Brackets. Temporarily support the weight of the Bumper. **WARNING:** To avoid possible injury or damage to the vehicle, do not proceed until the Bumper is fully and safely supported. **NOTE:** It may be easier to install sensors and accessory lighting before installing the Bumper, (models with tow hooks for example). See **Steps 10 & 11** regarding sensors and lighting if desired.
8. Attach the mounting tab on the back of the driver/left side of the Bumper to the Frame Bracket with (3) 10mm x 35mm Hex Bolts, (6) 10mm Flat Washers, (3) 10mm Lock Washers and (3) 10mm Hex Nuts, **(Figures 9 & 10)**. Do not fully tighten at this time. Repeat this Step to attach the passenger/right side of the Bumper to the Frame Bracket.
9. Select the driver/left triangle shaped Top Corner Fill Panel, **(Figure 11)**. Attach the Panel to the top of the bumper with (2) 6mm x 20mm Button Head Screws, (2) 6mm Lock Washers and (2) 6mm x 12mm Small Flat Washers, **(Figures 11 & 12)**. **NOTE:** The Driver and passenger side Top Corner Fill Panels look similar but are unique. The side of the triangle with the small notch, **(Figure 11)**, will go toward the rear, (toward the fender). Repeat to install the passenger/right Top Corner Fill Panel.
10. Level and adjust the bumper and fully tighten all hardware.

Models without bumper sensors:

- a. Select the included (6) Rubber Plugs.
- b. From behind bumper, push plugs into sensor mounting holes, **(Figure 13)**.

Models with bumper mounted sensors:

- a. Push the sensor into the mounting socket in the back of the bumper.
- b. Secure each sensor to the socket with (2) 4mm x 10mm Button Head Screws, **(Figure 13)**. **IMPORTANT:** Sensors fit snug in sockets. The 4mm Screws are used to apply slight pressure to lock the sensors in place. Tighten both screws evenly until they touch the sensor body only. Do not overtighten screws or damage to sensors will result.
11. If front license plate is required, attach the License Plate Bracket to the holes in the bumper with the included (2) 6mm x 20mm Button Head Screws, (4) 6mm x 18mm Large Flat Washers and (2) 6mm Nylon Lock Nuts. Insert (2) Plastic Plugs into the square holes in the Bracket. Reuse the factory screws to attach the license plate to the plastic plugs, **(Figure 14)**.

Center LED light installation as supplied with bumper or sold separately.

- a. Select the L/R "L" Brackets, **(Figure 15)**. Attach the Brackets to the top of the (2) mounting tabs welded onto the back of the bumper with the included 8mm x 25mm Hex Bolts, (4) 8mm Flat Washers, (2) 8mm Lock Washers and (2) 8mm Hex Nuts. Leave loose at this time.
- b. Attach the LED light assembly to the "L" Brackets with the included (2) 8mm x 16mm Hex Bolts, (2) 8mm Lock Washers and (2) 8mm Flat Washers. Do not fully tighten hardware at this time. **IMPORTANT:** "L" Brackets are designed for 8mm light mounting hardware only. Modify "L" Brackets if necessary or use brackets supplied by your light manufacturer if possible to install hardware larger than 8mm.
- c. Follow light manufacturer's instructions to properly wire the light.

LED light installation at ends of bumper as supplied with bumper or sold separately.

- d. Insert light into opening and up to mounting slots. Check for clearance between front and back of light. If necessary, remove screen from back of opening, **(Figure 16)**.
- e. Follow the light manufacturer's instructions to attach (1) light to the center slot or (2) lights to the inner and outer slots in the top of the light opening, **(Figure 16)**.
IMPORTANT: On two light systems, attach the flood light to the outer slot and the spot light to the inner slot.
- f. Repeat the above steps for passenger side light installation.
- g. Follow light manufacturer's instructions to properly wire the light.

12. Do periodic inspections to the installation to make sure that all hardware is secure and tight.

To protect your investment, wax this product after installing. Regular waxing is recommended to add a protective layer over the finish. Do not use any type of polish or wax that may contain abrasives that could damage the finish. Mild soap may be used to clean the Bumper assembly.

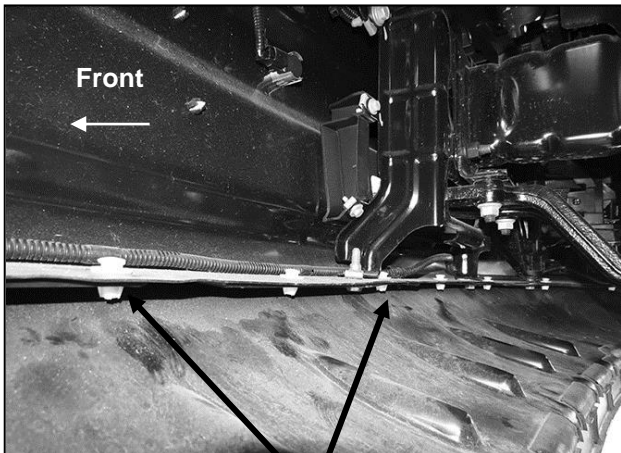

(Fig 1) Release clips (arrow) to remove air dam (pictured from behind bumper-tow hook equipped)



(Fig 2) Unplug lights and sensors if equipped. Unplug harness to bumper and move harness



(Fig 3) Pull back fender liner to locate fascia attachment at bottom of front fender



(Fig 4) Remove fascia body panel from top of bumper

Driver Side Installation Pictured

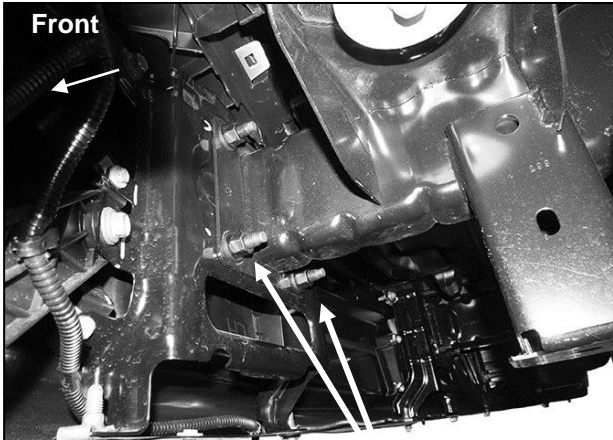

(Fig 5) Remove (3) factory hex nuts from each side

12mm x 35mm Hex Bolt
(2) 12mm Flat Washers
12mm Lock Washer
12mm Hex Nut

10mm x 35mm Hex Bolt
(2) 10mm Flat Washers
10mm Lock Washer
10mm Hex Nut

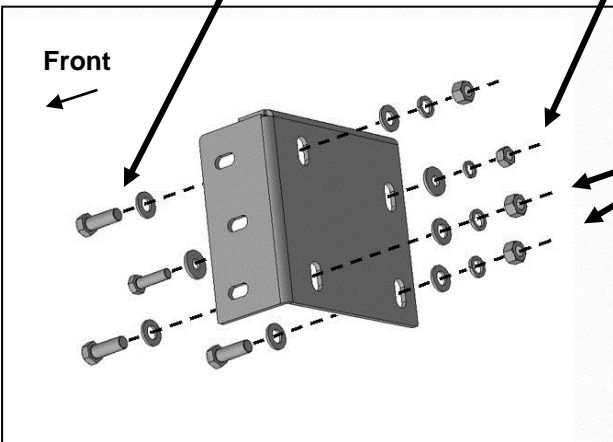

(Fig 7) Attach driver/left Bracket to end of frame

(2) 12mm x 35mm Hex Bolts
(4) 12mm Flat Washers
(2) 12mm Lock Washers
(2) 12mm Hex Nuts

10mm x 35mm Hex Bolt
(2) 10mm Flat Washers
10mm Lock Washer
10mm Hex Nut

(3) 12mm x 35mm Hex Bolts
(6) 12mm Flat Washers
(3) 12mm Lock Washers
(3) 12mm Hex Nuts

WARNING! Do not crawl under bumper unless the bumper is properly supported on blocks or stands or the bumper may fall.

WARNING! Do not remove bumper bolts unless the bumper is properly supported on blocks or stands or the bumper may fall.

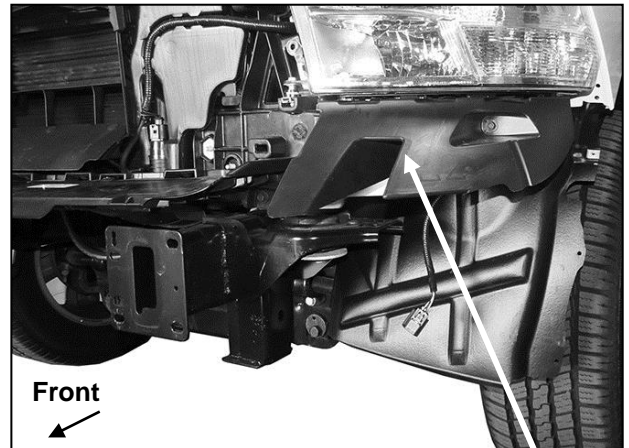

(Fig 6) Remove plastic block from below headlight

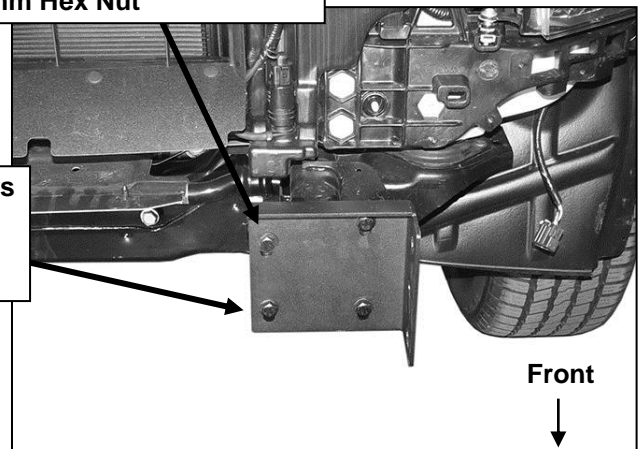

(Fig 8) Driver/left Mounting Bracket installed

Driver Side Installation Pictured

WARNING! Do not crawl under bumper unless the bumper is properly supported on blocks or stands or the bumper may fall.

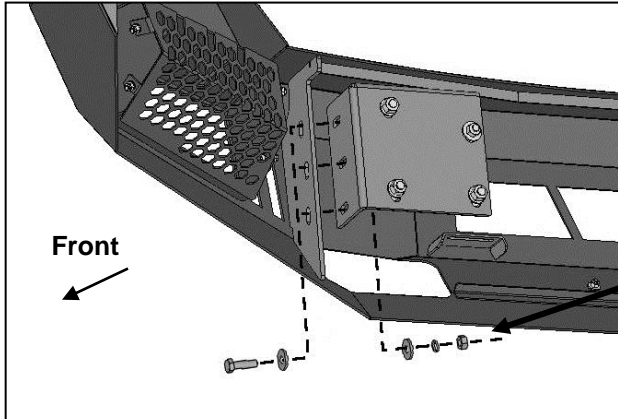

- (3) 10mm x 35mm Hex Bolts
- (6) 10mm Flat Washers
- (3) 10mm Lock Washers
- (3) 10mm Hex Nuts

(Fig 9) Attach Bumper to Mounting Brackets

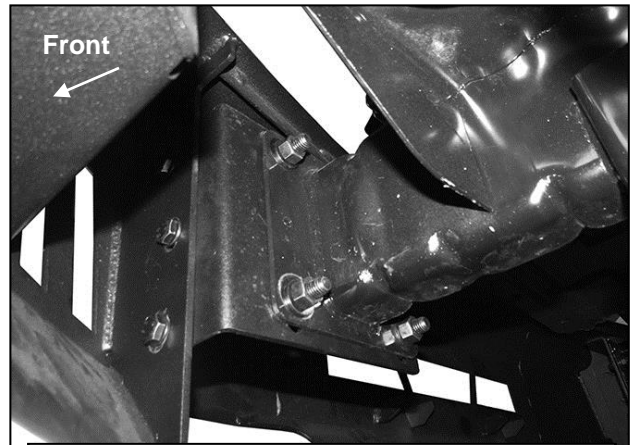

(Fig 10) Driver/left side complete installation

NOTE: Notch (arrow) designates rear of triangle Fill Panel

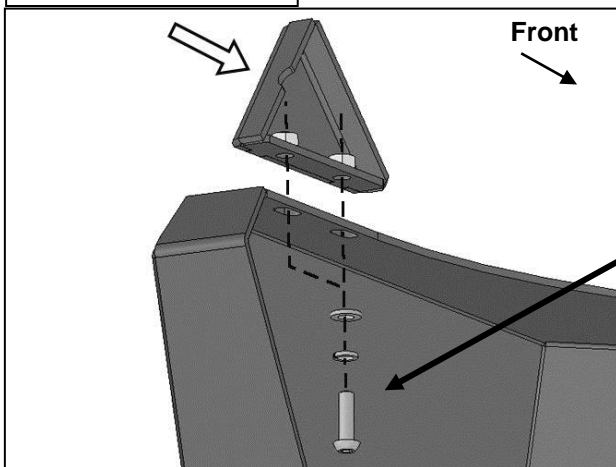

- (2) 6mm x 20mm Button Head Screws
- (2) 6mm Lock Washers
- (2) 6mm x 12mm Small Flat Washers

(Fig 11) Attach Driver/left side triangle Fill Panel to top corner of Bumper assembly

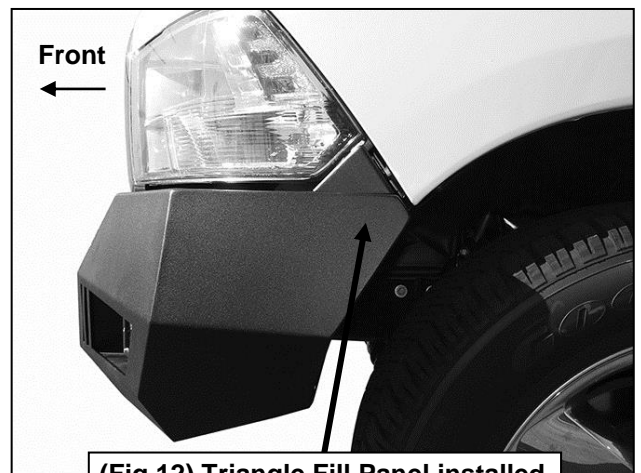

(Fig 12) Triangle Fill Panel installed

Driver Side Installation Pictured

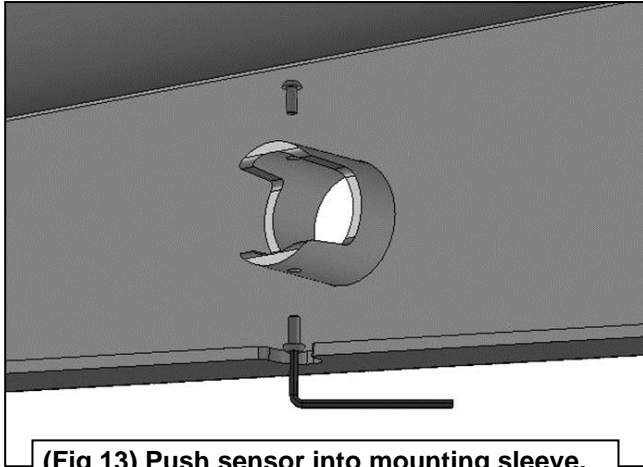

(Fig 13) Push sensor into mounting sleeve. Use 4mm Screws to lock sensor in place.

IMPORTANT: Sensors fit snug in sockets. The 4mm Screws are only used to apply slight pressure to lock the sensors in place. Tighten both screws evenly until they touch the sensor body only. Do not overtighten screws or damage to sensors will result.

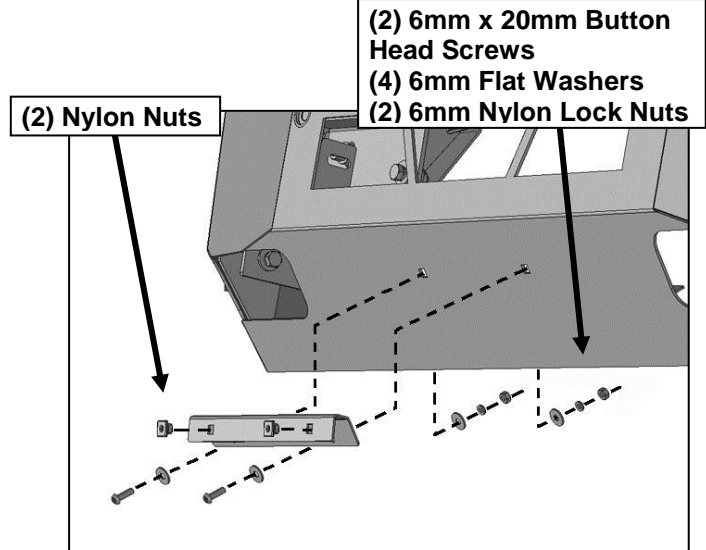

(Fig 14) Attach License Plate Bracket to Bumper

- (2) 8mm x 16mm Hex Bolts
- (2) 8mm Lock Washers
- (2) 8mm Flat Washers

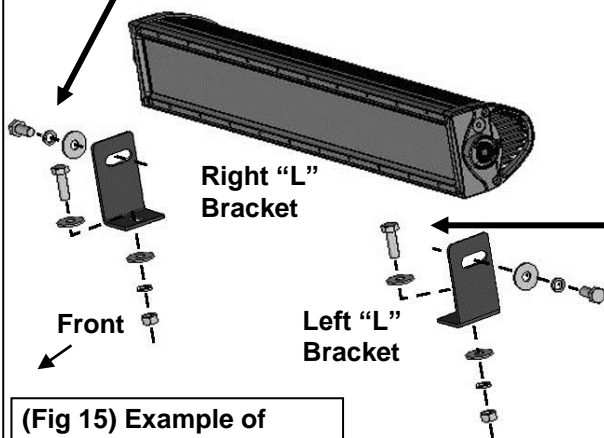

(Fig 15) Example of center light installation

- (2) 8mm x 25mm Hex Bolts
- (4) 8mm Flat Washers
- (2) 8mm Lock Washers
- (2) 8mm Hex Nuts

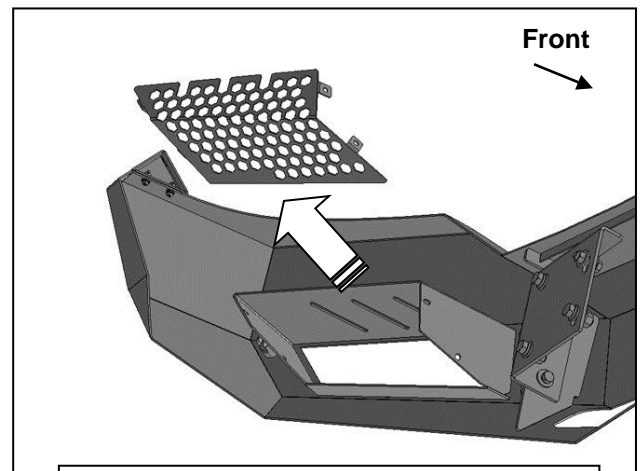

(Fig 16) Remove screens if necessary for clearance/access to outer light mounts



Complete Installation. Lights pictured for example only