



INSTALLATION INSTRUCTIONS

BLACK MODULAR GRILL GUARD

FOR 99-03 F150 2WD / 99-03 F250 LD 2WD / 99-02 EXPEDITION 2WD

PART # 17FP27MA

PARTS LIST:

1	Grille Guard	2	8-1.25mm x 25mm Hex Bolts
1	Driver/Left Frame Mounting Bracket	4	8mm x 16mm OD x 1.6mm Flat Washers
1	Passenger/Right Frame Mounting Bracket	2	8mm Nylon Lock Nuts
2	Top Mounting Brackets	2	6-1.0mm x 25mm Button Head Bolts
2	"L" Top Support Brackets	4	6mm x 12mm OD x 1.6mm Flat Washers
10	12-1.75mm x 30mm Hex Bolts	2	6mm Nylon Lock Nuts
20	12mm x 24mm OD x 2.5mm Flat Washers	1	4mm Allen Wrench
10	12mm Nylon Lock Nuts		

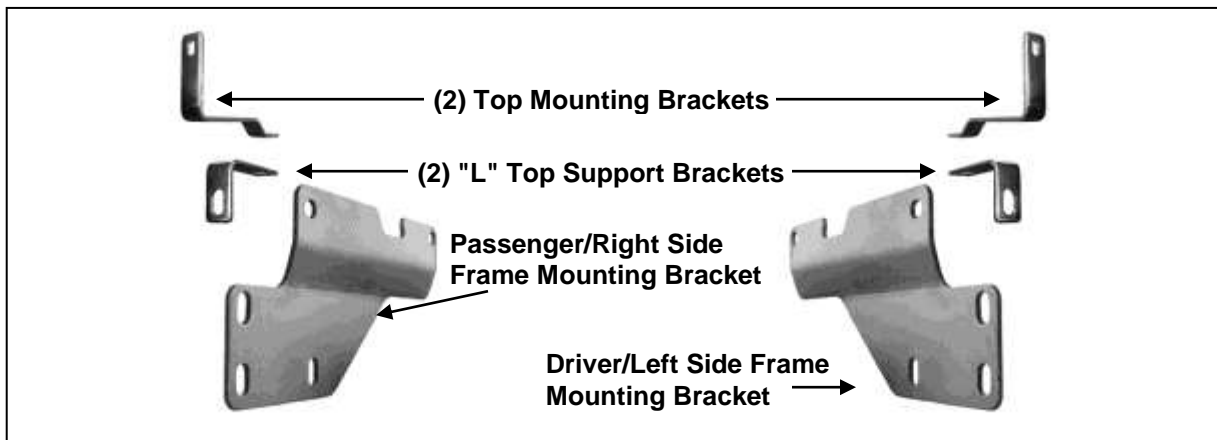
**PROCEDURE:**

- REMOVE CONTENTS FROM BOX. VERIFY ALL PARTS ARE PRESENT. READ INSTRUCTIONS CAREFULLY BEFORE STARTING INSTALLATION. ASSISTANCE IS RECOMMENDED. CUTTING MAY BE REQUIRED.**
- Depending on model and year, the plastic bumper cover or lower spoiler may need to be temporarily removed to access the end of the frame. Also, the cover or spoiler may need to be trimmed to clear the Frame Mounting Brackets. Cut the least amount of material possible to maintain the strength of the plastic components, **(Figures 3 & 12)**.
- Starting on the driver side of the vehicle, hold the driver side Frame Bracket up against the outside of the frame. Match up the top mounting holes in the Bracket with the holes in the frame, **(Figure 1)**. Insert (1) 12mm Hex Bolt with (1) 12mm Flat Washer into the open end of the frame and out through the rear mounting hole, **(Figure 2)**. Attach the Bracket to the 12mm Bolt with (1) 12mm Flat Washer and (1) 12mm Nylon Lock Nut, **(Figure 3)**. Leave loose at this time. Repeat this procedure to bolt the Bracket to the forward mounting location at the end of the frame. Snug but do not fully tighten the hardware at this time.
- Repeat **Step 3** to install the passenger side Frame Mounting Bracket.
- Next, remove the factory hex bolt located on the back of the front bumper securing the bumper to the top of the bumper bracket, **(Figure 4)**. Select (1) "L" Top Support Bracket and attach it to the back of the bumper bracket using the factory hex bolt, **(Figure 5)**. Snug but do not tighten hardware at this time. Repeat this Step to install the passenger side "L" Top Support Bracket.
- Select (1) Top Mounting Bracket, **(Figure 6)**. Insert the Bracket through the opening in the bottom of the grille, **(Figures 7 & 8)**. **NOTE:** It is also recommended to cover the bumper with masking tape to prevent damage to finish during Grille Guard installation.
- Bolt the Top Mounting Bracket to the "L" Top Support Bracket installed in **Step 5** using (1) 8mm Hex Bolt, (2) 8mm Flat Washers and (1) 8mm Nylon Lock Nut, **(Figures 9A & 9B)**. Do not tighten at this time. Repeat this step for passenger side Top Bracket installation.

8. With assistance, position the mounting tabs on the Grille Guard up to the outside of the Frame Mounting Brackets and bolt together with the included (6) 12mm x 30mm Hex Bolts, (12) 12mm Flat Washers and (6) 12mm Nylon Lock Nuts, **(Figure 10)**. Snug but do not tighten hardware at this time.
9. Move the Grille Guard into position and line up the Top Mounting Brackets with the mounting slots in the back of the cross bar. Bolt the Top Mounting Brackets to the cross bar with (2) 6mm Button Head Bolts, (4) 6mm Flat Washers and (2) 6mm Nylon Lock Nuts, **(Figure 11)**.
10. With the hood open, push the Grille Guard back until it is upright. Align, center and adjust the Grille Guard properly. Do not tighten the hardware securing the Grille Guard to the Brackets. Carefully close the hood and check for clearance between the Top Brackets and the factory grille insert. Once all Brackets have been checked for clearance, tighten all hardware securing the Brackets to the vehicle only, including the hardware behind the bumper and Mounting Brackets. Remove the Grille Guard. Reinstall the lower bumper cover removed in **Step 2**. Trim the bumper cover to clear Brackets as necessary. Reinstall the Grille Guard as described in **Steps 8 & 9** and fully tighten all hardware, **(Figure 12)**.
11. Do periodic inspections to the installation to make sure that all hardware is secure and tight.

To protect your investment, wax this product after installing. Regular waxing is recommended to add a protective layer over the finish. Do not use any type of polish or wax that may contain abrasives that could damage the finish.

For stainless steel: Aluminum polish may be used to polish small scratches and scuffs on the finish. Mild soap may be used also to clean the Grille Guard.

For gloss black finishes: Mild soap may be used to clean the Grille Guard.

Driver Side Installation Pictured

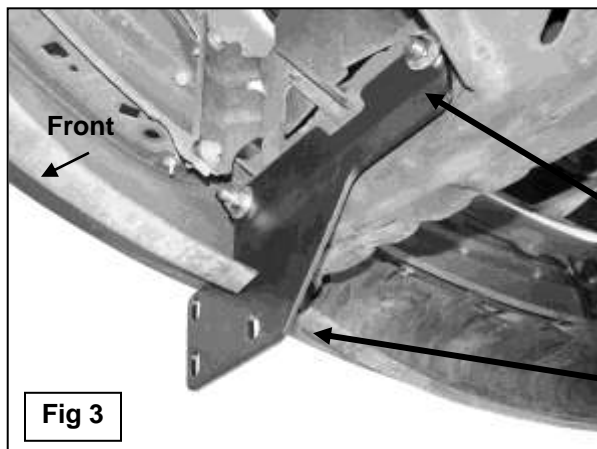
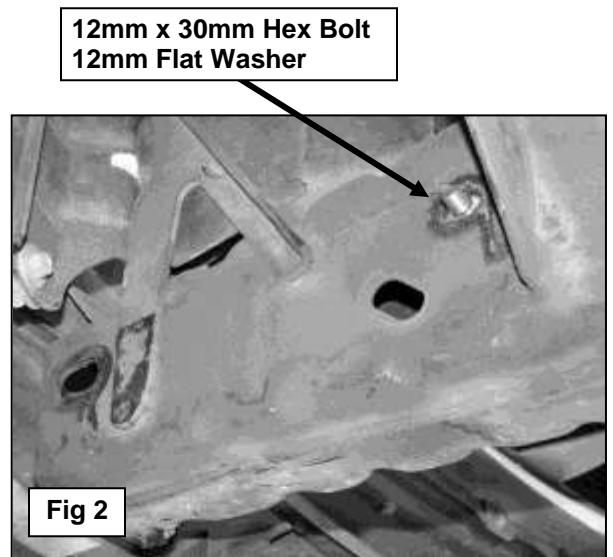
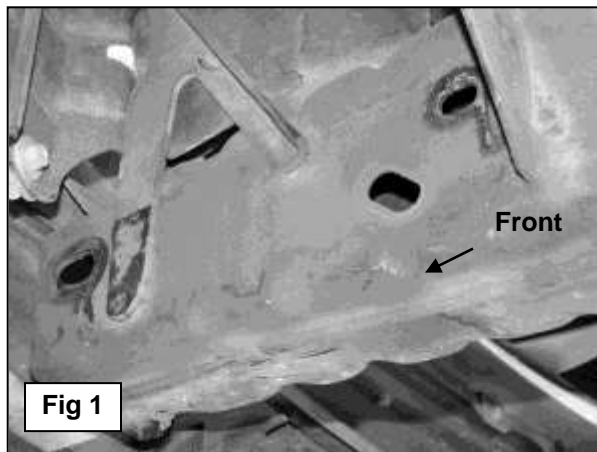

(2) 12mm x 30mm Hex Bolts
(4) 12mm Flat Washers
(2) 12mm Nylon Lock Nuts

Trimming to the plastic bumper may be required for Mounting Bracket clearance

Driver Side Installation Pictured

Remove factory hex bolt

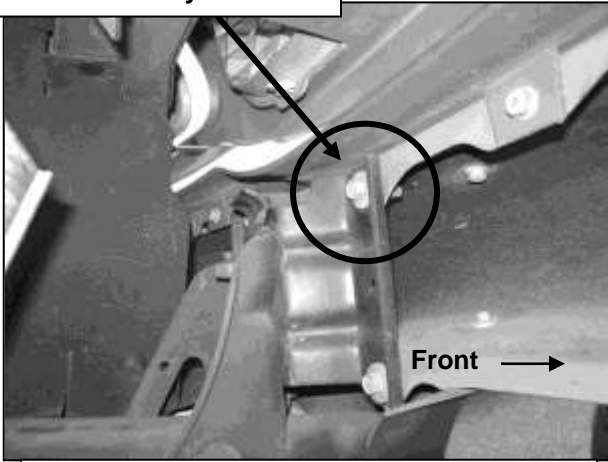

(Fig 4) Driver side-back of bumper pictured

Use factory hex bolt to attach "L" Top Support Bracket

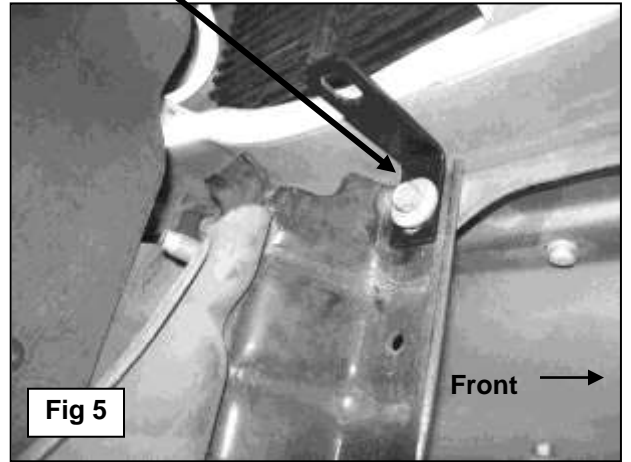

Fig 5

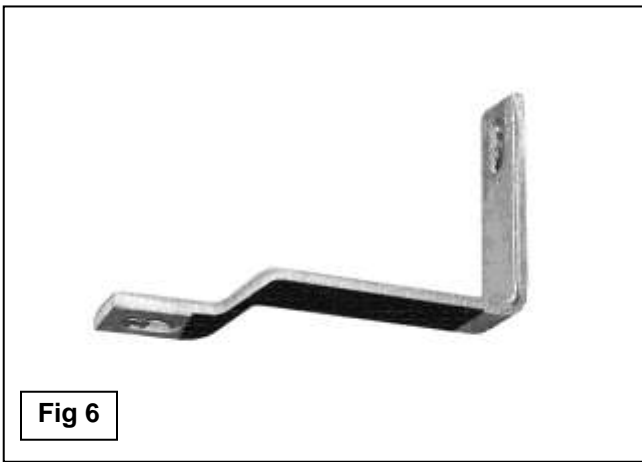

Fig 6



Fig 7

Insert Top Mounting Bracket between grille and top of bumper

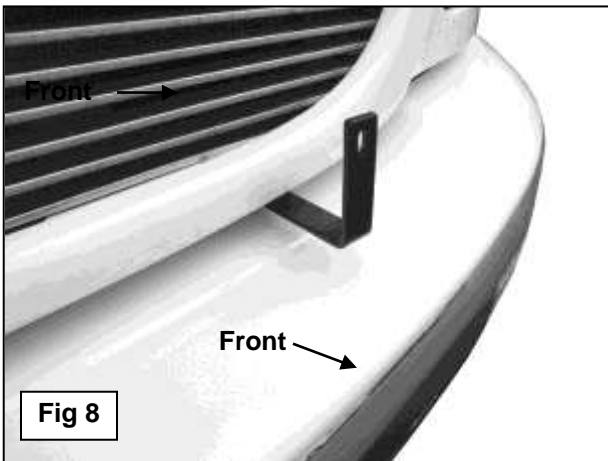
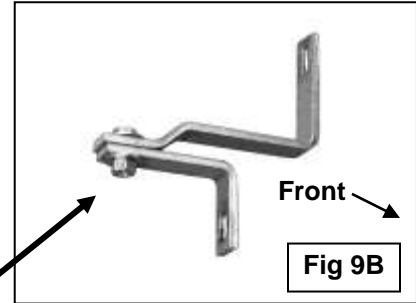
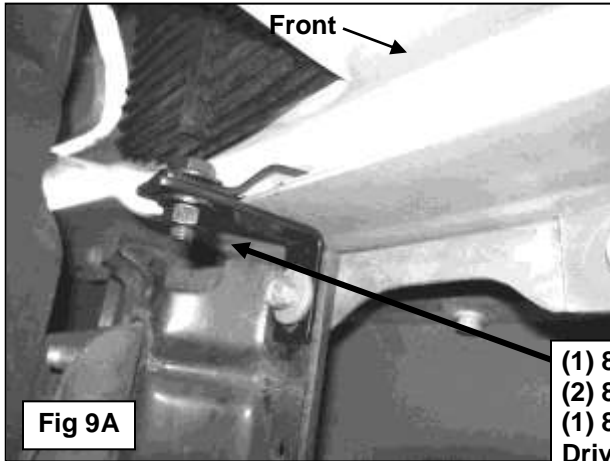
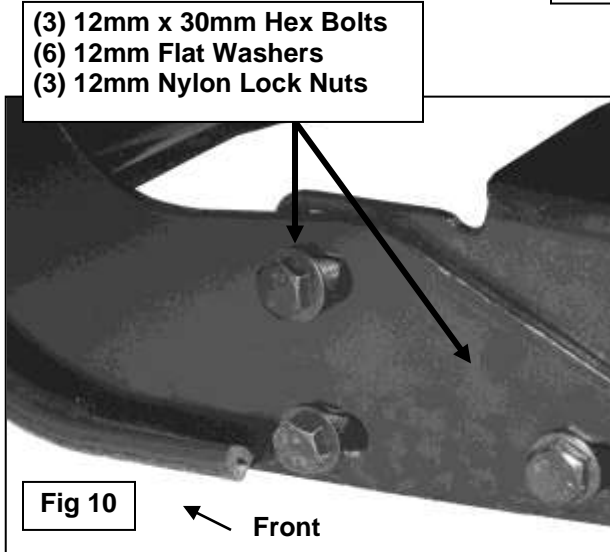

Fig 8

Driver Side Installation Pictured



- (1) 8mm x 25mm Hex Bolt
 - (2) 8mm Flat Washers
 - (1) 8mm Nylon Lock Nut
- Driver side-back of bumper pictured



- (3) 12mm x 30mm Hex Bolts
- (6) 12mm Flat Washers
- (3) 12mm Nylon Lock Nuts

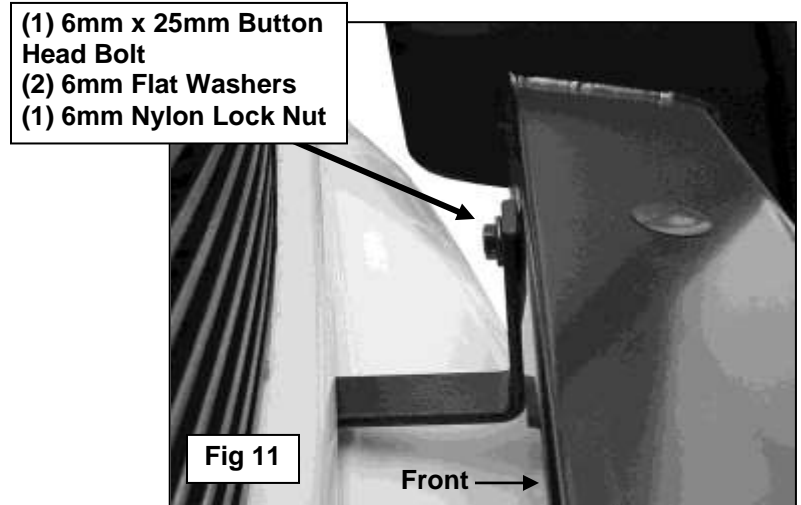

- (1) 6mm x 25mm Button Head Bolt
- (2) 6mm Flat Washers
- (1) 6mm Nylon Lock Nut

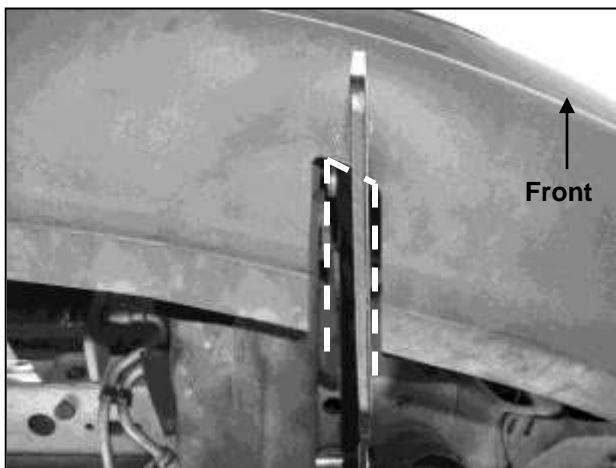

(Fig 12) Driver side Bracket installation pictured from below bumper cover. Cut cover as necessary to clear Brackets



Brush Guard PARTS LIST:

①	Nut M8	6
②	Flat washer D8 (8x24x2mm)	12
③	Button Head Bolt M8_25	6
④	Spring washer D8	6
⑤	Allen Wrench S=5	1

Brush Guard Installation:

