



# INSTALLATION INSTRUCTIONS

PART # BBTY918-SP

BULL BAR FOR TOYOTA SIENNA 11-13

**PARTS LIST:**

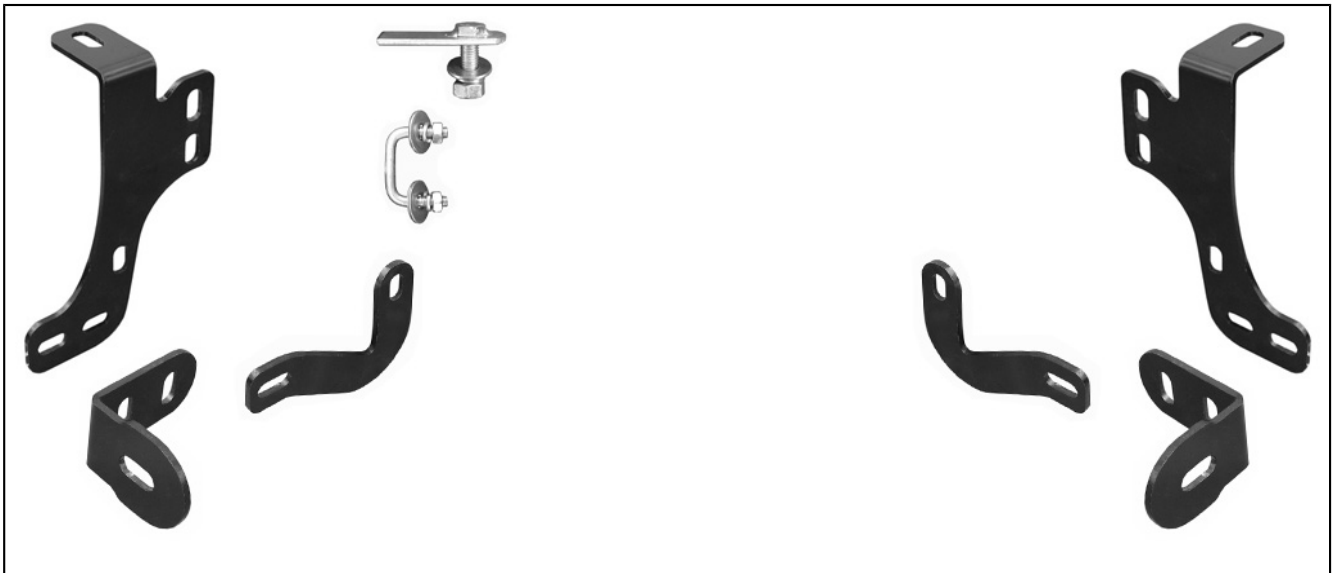

1	Driver/Left Frame Mounting Bracket	6	12-1.75mm x 35mm Hex Bolts
1	Pass/Right Frame Mounting Bracket	14	12mm x 32mm x 3mm Flat Washers
1	Driver/Left Support Bracket	2	12mm x 37mm x 3mm Large Flat Washers
1	Pass/right Support Bracket	10	12mm Lock Washers
2	Bull Bar Mounting Brackets	8	12mm Hex Nuts
2	12-1.75mm x 40mm Bolt Plates	4	8mm Lock Washers
2	8-1.25mm x 40mm U-Bolts	4	8mm x 28mm x 3mm Flat Washers
2	12-1.75mm x 40mm Hex Bolts	4	8mm Hex Nuts

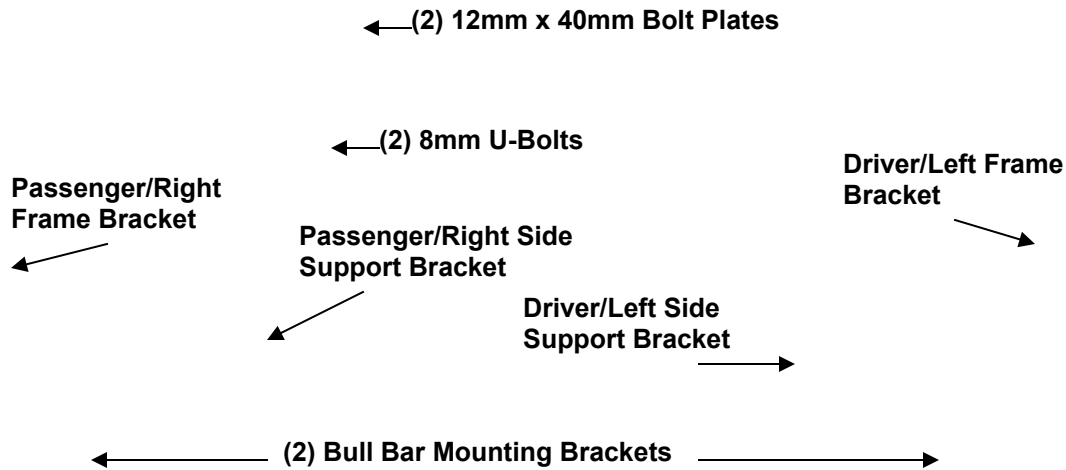

#### PROCEDURE:

1. REMOVE CONTENTS FROM BOX. VERIFY ALL PARTS ARE PRESENT. READ INSTRUCTIONS CAREFULLY BEFORE STARTING INSTALLATION. ASSISTANCE RECOMMENDED. CUTTING IS REQUIRED.
2. Remove the front plastic splash guard from under the front bumper and place it on a clean, stable work area.
3. From under the driver side, front of the vehicle, locate the frame channel and crossmember, (**Figure 1**). Insert (1) 12mm Bolt Plate into the opening in the bottom of the frame channel with the threaded bolt toward the outside of the vehicle, (**Figures 2A & 2B**). Next, insert (1) 8mm U-Bolt into the small round hole and up and out the larger oval hole in the side of the radiator mount, (**Figures 2A & 2C**).
4. Hold the driver side Frame Mounting Bracket up in position over the Bolt Plate. Hang the Bracket from the 12mm Bolt Plate with (1) 12mm Lock Washer, (1) 12mm Flat Washer and (1) 12mm Hex Nut, (**Figure 3**). Leave loose at this time. Line up the (2) holes in the Bracket with the previously installed U-Bolt. Secure the Bracket to the U-Bolt with (2) 8mm Lock Washers, (2) 8mm Flat Washers and (2) 8mm Hex Nuts, (**Figure 4**). Snug but do not tighten hardware at this time.
5. Remove the factory hex bolt in the side of the radiator crossmember. Select the driver side Support Bracket, (**Figure 5**). Bolt the Bracket to the crossmember with the factory hex bolt. Bolt the Support Bracket to the back of the Frame Bracket with (1) 12mm Hex Bolt, (2) 12mm Flat Washers, (1) 12mm Lock Washer and (1) 12mm Hex Nut, (**Figure 6**). Snug but do not fully tighten all hardware.
6. Next, select (1) Bull Bar Mounting Bracket. Bolt the Bracket to the inside of the Frame Bracket with (2) 12mm Hex Bolts, (4) 12mm Flat Washers, (2) 12mm Lock Washers and (2) 12mm Hex Nuts, (**Figure 7**). Do not tighten hardware at this time.
7. Repeat **Steps 3 – 6** for passenger side Mounting Bracket installation.
8. With assistance, position the Bull Bar up to the Mounting Brackets. Attach the Bull Bar to the Mounting Brackets using the included (2) 12mm x 35mm Hex Bolts, (2) 12mm Lock Washers and (2) 12mm Flat Washers, (**Figure 8**).
9. Level and adjust the Bull Bar properly and tighten all hardware securing the Brackets to the vehicle only. Temporarily remove the Bull Bar.

10. Hold the factory plastic splash guard up in its original mounting position and trace the location of the (2) Mounting Brackets onto the splash guard, (**Figures 9 & 10**) Use a sharp knife to cut out the traced area for the Mounting Brackets, (**Figure 11**). **IMPORTANT:** To maintain strength in the splash guard, only remove necessary material to clear the Mounting Brackets.
11. Completely secure the splash guard to the vehicle with the factory hardware.
12. Reinstall the Bull Bar as described in Steps 8 – 9. Tighten all hardware.
13. Do periodic inspections to the installation to make sure that all hardware is secure and tight.

**To protect your investment**, wax this product after installing. Regular waxing is recommended to add a protective layer over the finish. Do not use any type of polish or wax that may contain abrasives that could damage the finish.

**For stainless steel:** Aluminum polish may be used to polish small scratches and scuffs on the finish. Mild soap may be used also to clean the Bull Bar.

**For gloss black finishes:** Mild soap may be used to clean the Bull Bar.

### Driver Side Installation Pictured

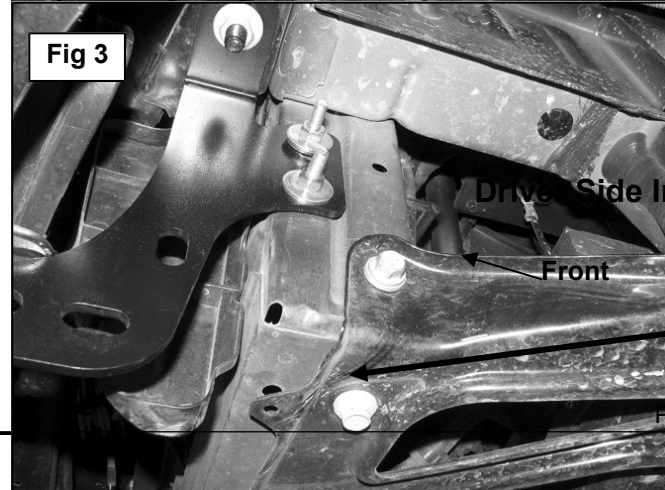
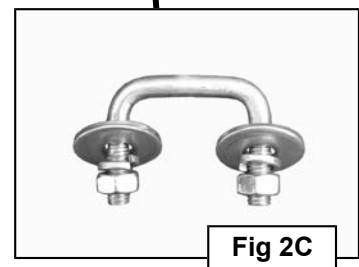
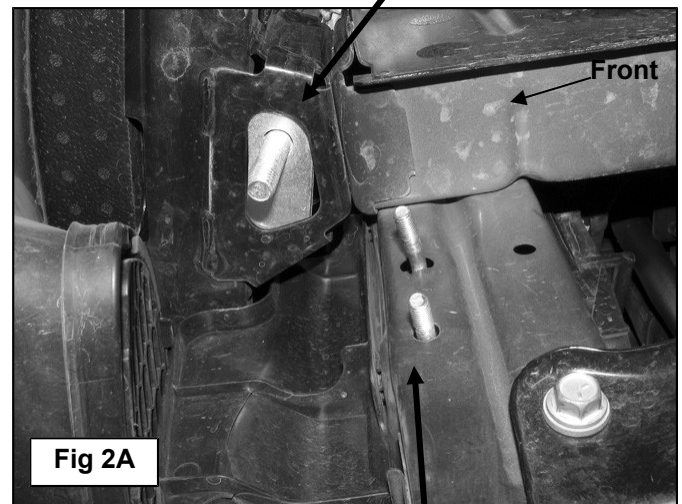
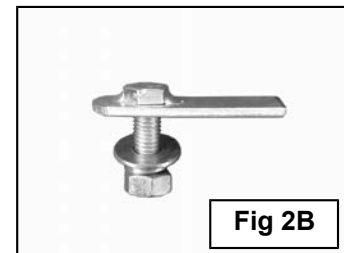
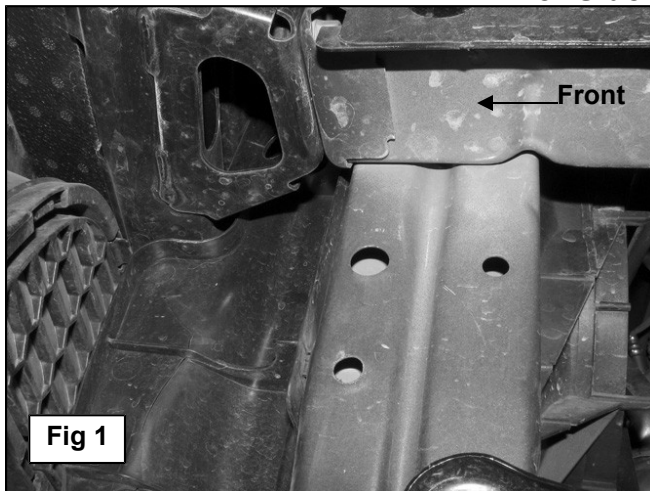

### Driver Side Installation Pictured

- (2) 8mm Flat Washers
- (2) 8mm Lock Washers
- (2) 8mm Hex Nuts

Remove factory hex bolt

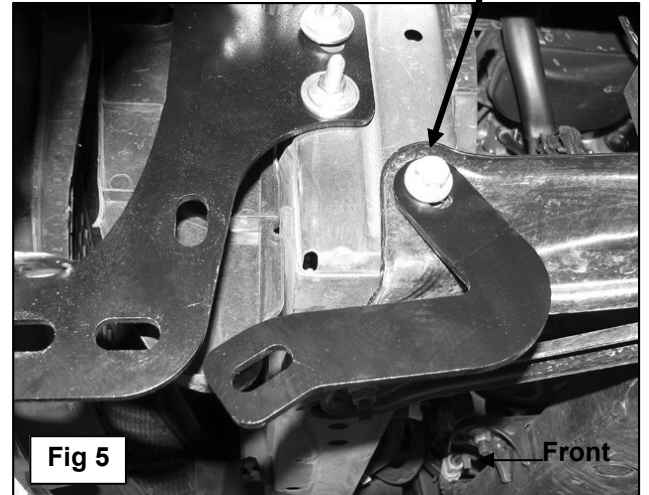
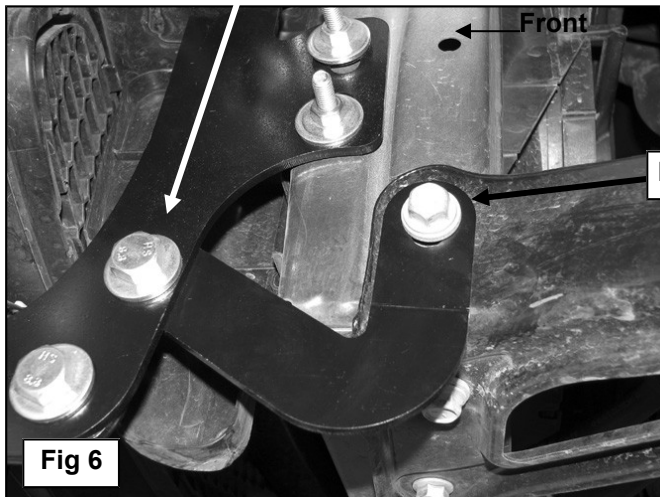

Fig 4

- 12mm x 35mm Hex Bolt
- (2) 12mm STD Flat Washers
- 12mm Lock Washer
- 12mm Hex Nut



Factory hex bolt

Fig 6

- (2) 12mm x 35mm Hex Bolts
- (4) 12mm STD Flat Washers
- (2) 12mm Lock Washers
- (2) 12mm Hex Nuts

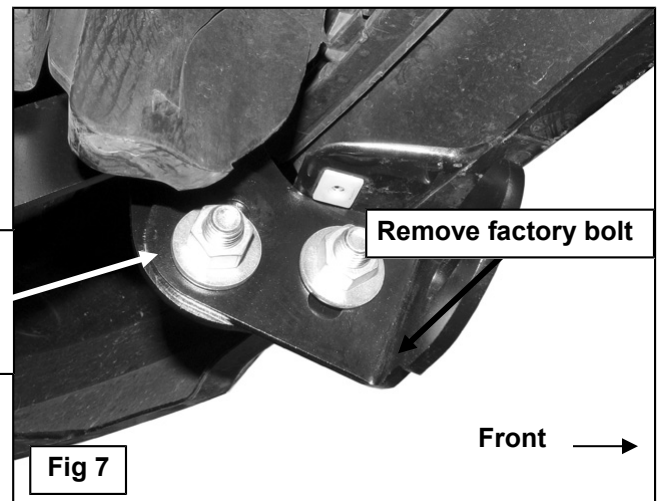

Remove factory bolt

Fig 7



Driver Side Installation Pictured

← Front

**Fig 8**

- 12mm x 40mm Hex Bolt
- 12mm x 37mm Large Flat Washer
- 12mm Lock Washer

