



INSTALLATION INSTRUCTIONS

PART#: BB992804SS/BB992804A
2.5" BULL BAR W/O SKID PLATE FOR MAZDA CX9 08-10



PARTS LIST:

1	Sport Bar	2	10-1.50mm x 35mm Hex Head Bolts
1	Driver/Left Mounting Bracket	4	10mm Lock Washers
1	Passenger/Right Mounting Bracket	4	10mm Hex Nuts
1	Driver/Left Support Bracket	6	10mm ID x 27mm OD x 3mm Flat Washers
1	Passenger/Right Support Bracket	8	12-1.75mm x 35mm Hex Head Bolts
2	12mm Double Nut Plates	2	12-1.75mm x 80mm Hex Head Bolts
2	10-1.50mm x 30mm Bolt Plates	10	12mm Lock Washers
		6	12mm Hex Nuts
		16	12mm ID x 32mm OD x 3mm Flat Washers

Passenger Side Mounting Bracket



Driver Side Mounting Bracket



Passenger Side Support Bracket



Driver Side Support Bracket



**12mm Double Nut Plate
(2 pieces)**



**10mm Bolt Plate
(2 pieces)**



PROCEDURE:

- 1. REMOVE CONTENTS FROM BOX. VERIFY ALL PARTS ARE PRESENT. READ INSTRUCTIONS CAREFULLY BEFORE STARTING INSTALLATION.**
2. From underside of vehicle, remove the center and corner splash shields. Set splash shields on a clean working area, then trim to fit as shown in **(Figure 1 & 2)**.
3. Starting on the driver side of the vehicle, locate the two small and one large round factory holes in the front end of frame rail. Through larger round hole insert (1) 12mm Double Nut Plate into frame rail and oriented it to inside (rear) small round hole **(Figure 3)**.
4. Insert (1) 12mm x 80mm Hex Head Bolt and (1) 12mm Flat Washer through the top of frame rail and orient them to the small front hole in the bottom of frame rail **(Figure 4)**.
5. Position driver side Mounting Bracket over already inserted 12mm x 80mm Hex Head Bolt and Nut Plate. Partially hang driver side Mounting Bracket from Nut Plate using the included (2) 12-1.75mm x 35mm Hex Head Bolts, (2) 12mm Lock Washers, and (2) 12mm Flat Washers and secure the 12mm x 80mm Hex Head Bolt with the included (1) 12mm Lock Washer, (2) 12mm Flat Washers, and (1) 12mm Hex Nut **(Figure 5)**.
6. Locate driver side Support Bracket and attach it to rear bottom hole in the previously attached Mounting Bracket using the included (1) 10-1.50mm x 35mm Hex Head Bolt, (1) 10mm Hex Nut, (2) 10mm Flat Washers, and (1) 10mm Lock washer **(Figure 6)**. Do not tighten at this time.
7. Extend Support Bracket towards the rear of the vehicle. The opposite mounting hole in the Support Bracket should reach its mounting location in the frame. Insert (1) 10mm Bolt Plate into factory hole in the frame **(Figure 7)**.
8. Attach the rear mounting location of the Support Bracket to previously inserted Bolt Plate using the included (1) 10mm Flat Washer and (1) 10mm Hex Nut, and (1) 10mm Lock Washer **(Figure 8)**. Do not tighten at this time.
9. Repeat steps 3 – 8 for passenger side.
10. With help position Sport Bar on the outer side on Mounting Brackets. Attach Sport Bar to Mounting Brackets using (4) 12mm x 35mm Hex Head Bolts, (4) 12mm Hex Nuts, and (8) 12mm Flat Washers, and (4) 12mm Lock Washers **(Figure 9)**. Do not tighten at this time.
11. Level and adjust Sport Bar, and then tighten all hardware at this time.
12. Re-install splash shields at this time using the factory fasteners.
13. Do periodic inspections to the installation to make sure that all hardware is secure and tight.

To protect your investment, wax this product after installing. Regular waxing is recommended to add a protective layer over the finish. Do not use any type of polish or wax that may contain abrasives that could damage the finish.

For stainless steel: Aluminum polish may be used to polish small scratches and scuffs on the finish. Mild soap may be used also to clean the Sport Bar.

For gloss black finishes: Mild soap may be used to clean the Sport Bar.

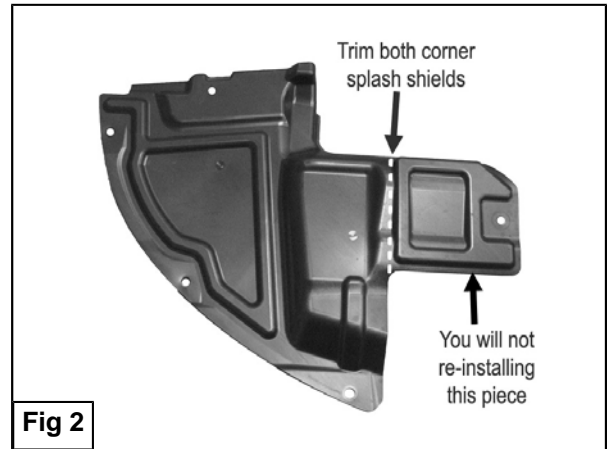
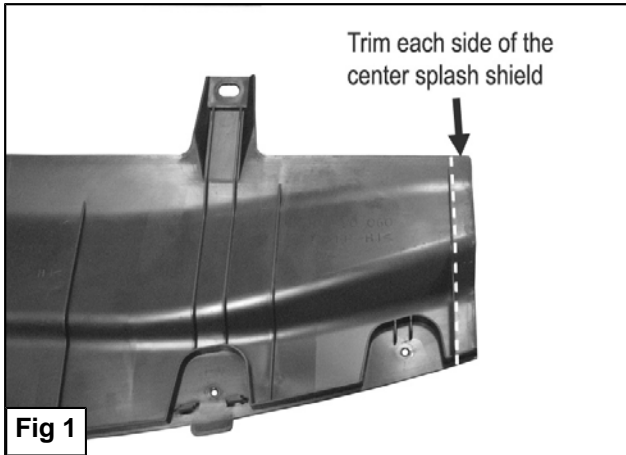

(Driver Side Installation Shown)

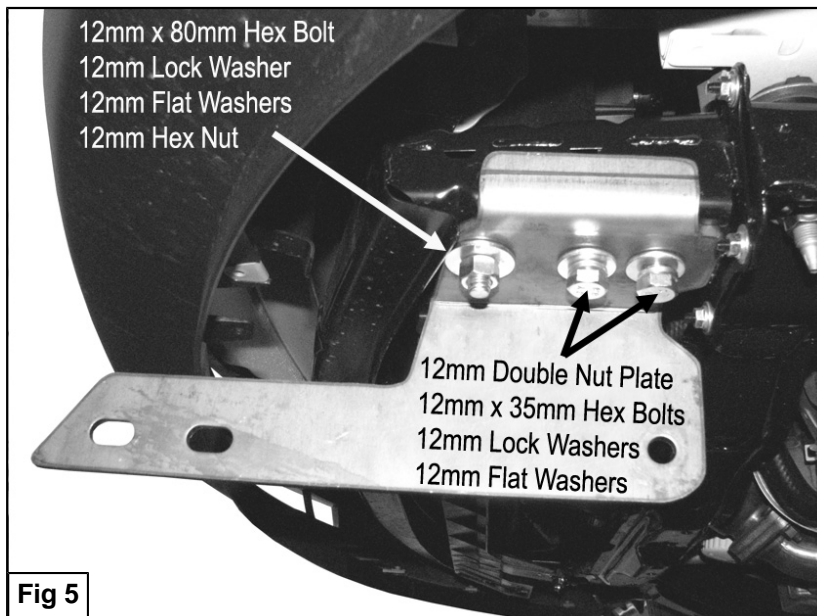
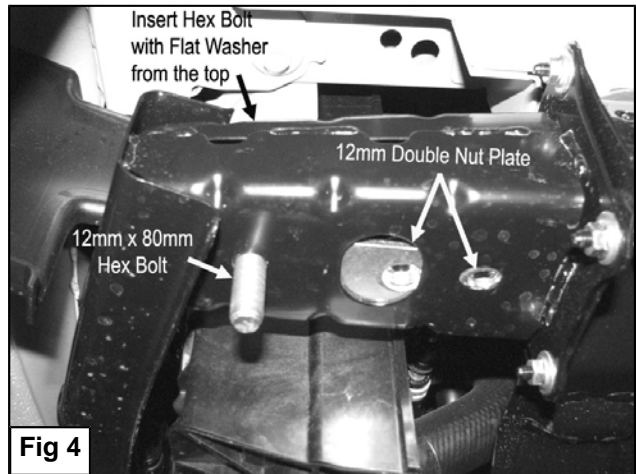
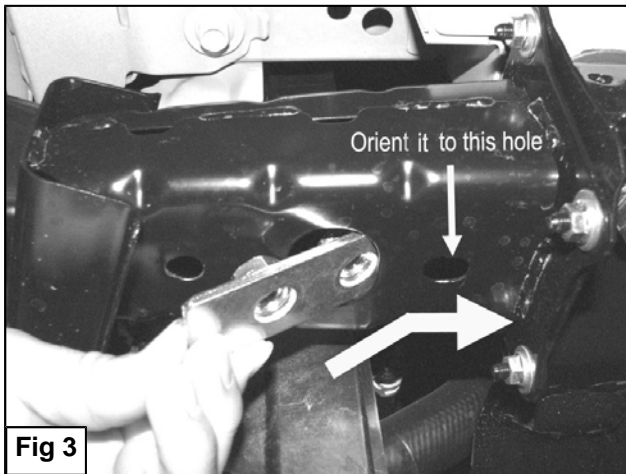

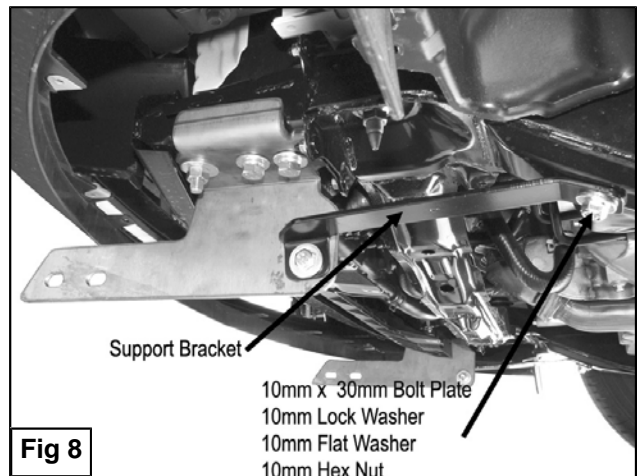
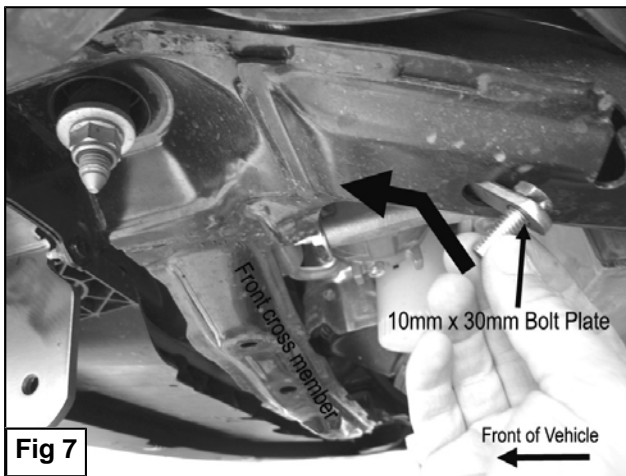
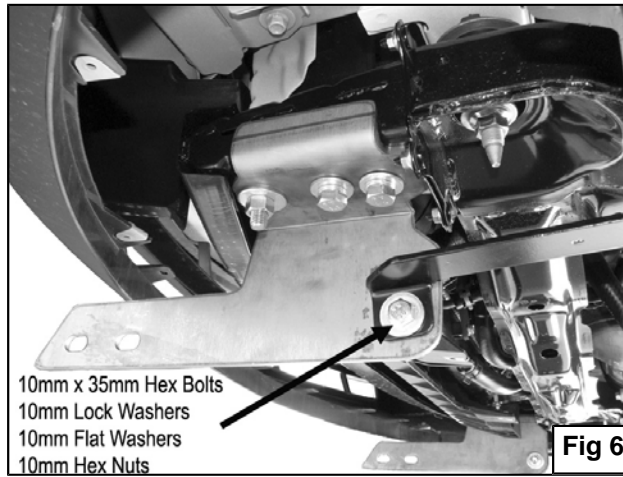

(Installation Shown Without Splash Shields)

