



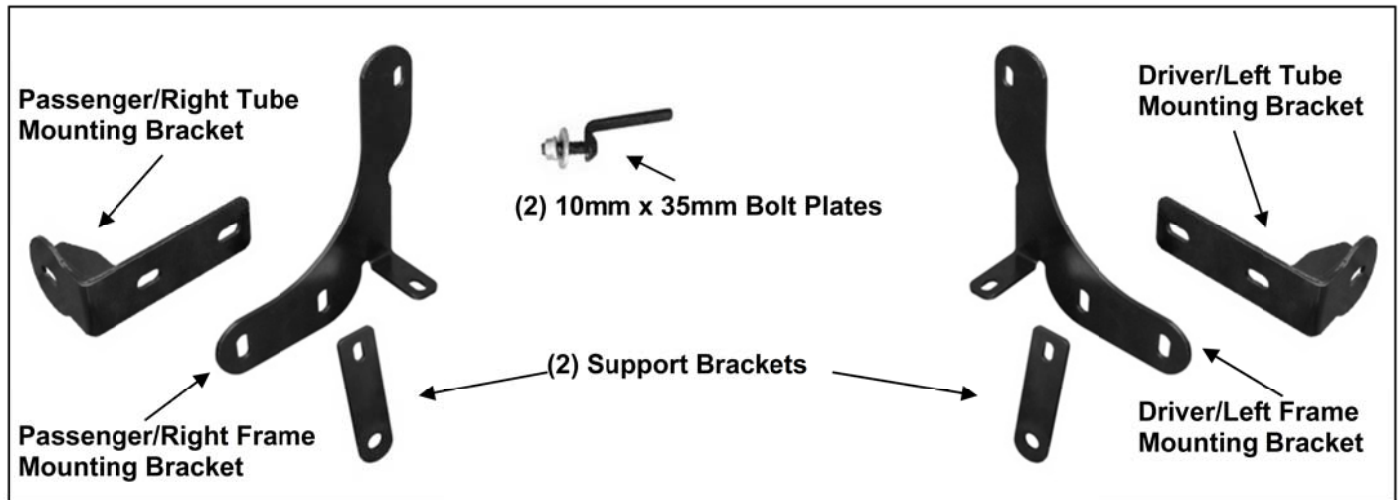
# **INSTALLATION INSTRUCTIONS**

**PART # BB141005SS/BB141005A**

**2.5 NUDGE BAR FOR MERCEDES BENZ 2012-2013**

**PARTS LIST:**

1	Sport Bar	8	12mm x 24mm OD x 2.5mm STD Flat Washers
1	Driver/Left Frame Bracket	6	12mm Lock Washers
1	Passenger/Right Frame Bracket	4	12-1.75mm Hex Nuts
1	Driver/Left Tube Mounting Bracket	2	10-1.50mm x 30mm Hex Bolts
1	Passenger/Right Tube Mounting Bracket	4	10mm x 30mm OD x 2.5mm Flat Washer
2	Support Brackets	4	10-1.50mm Serrated Flange Nuts
2	10-1.50mm x 35mm Angled Bolt Plates	2	8-1.25mm x 25mm Hex Bolts
2	12-1.75mm x 40mm Hex Bolts	4	8mm x 16mm OD x 1.6mm Flat Washers
4	12-1.75mm x 35mm Hex Bolts	2	8mm Lock Washer
2	12mm x 37mm OD x 3mm Large Flat Washers	2	8-1.25mm Hex Nuts



**PROCEDURE:**

**REMOVE CONTENTS FROM BOX. VERIFY ALL PARTS ARE PRESENT. READ INSTRUCTIONS CAREFULLY BEFORE STARTING INSTALLATION. CUTTING IS REQUIRED. NOT COMPATIBLE WITH FACTORY SKID PLATE AND/OR GRILLE GUARD. FRONT LICENSE PLATE BRACKET AND/OR LICENSE PLATE NEEDS TO BE REMOVED-RELOCATED.** If local/state law requires a front license plate, a license plate relocation kit is available separately.

1. Remove the license plate and bracket. From under the front of the vehicle, remove the center plastic splash guard below the front bumper, **(Figure 1)**. Place it on a clean, stable work area. To make reinstallation easier, note type and location of all factory fasteners. Remove metal clip nut from the sway bar bracket, **(Figure 2)**. Repeat this Step for passenger side clip nut.
2. Locate the factory hole in the inner frame channel, **(Figures 3A & 3B)**. Select the driver side Frame Mounting Bracket, **(Figure 10)**, and (1) 10mm Bolt Plate, **(Figure 4)**. Insert the Bolt Plate into the factory hole in the inner frame channel from the outside in, **(Figure 5)**. Hang the Frame Mounting Bracket from the Bolt Plate. Secure the Bracket to the Bolt Plate with (1) 10mm Flat Washer and (1) 10mm Flange Nut, **(Figure 6)**. Leave hardware loose at this time.
3. Line up the mounting tab on the frame bracket with the hole in the sway bar bracket, **(Figure 7)**. Insert (1) 10mm x 30mm Hex Bolt down through the tab on the sway bar bracket, the Frame Mounting

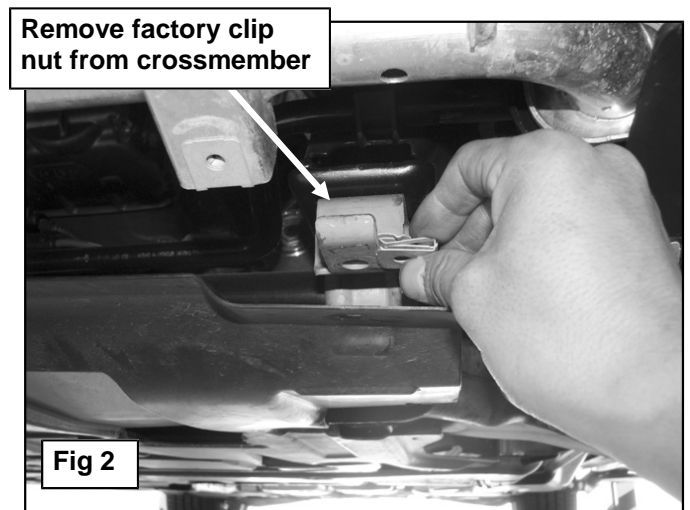
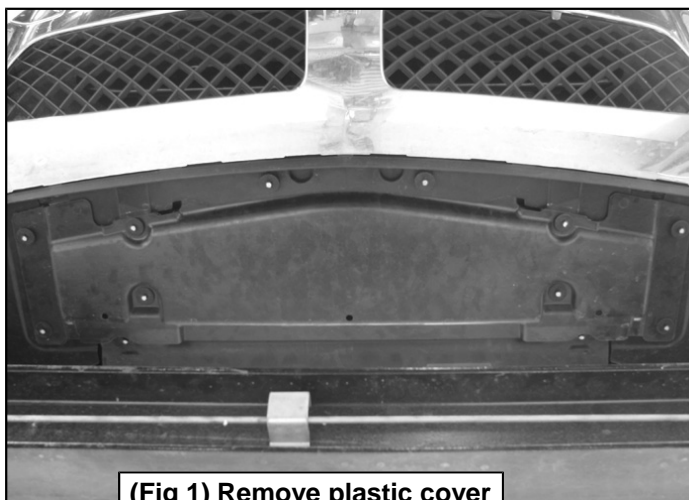
- Bracket and the plastic splash guard and secure with (1) 10mm Flat Washer and (1) 10mm Flange Nut, **(Figure 8)**. Tighten all Bracket hardware at this time.
4. Next, select (1) Support Bracket, **(Figure 9)**. Bolt the slotted end of the Support Bracket to the inside of the plate on the crossmember with (1) 8mm x 25mm Hex Bolt, (2) 8mm Flat Washers, (1) 8mm Lock Washer and (1) 8mm Hex Nut, **(Figure 10A)**. **IMPORTANT:** Depending on model year, it may be necessary to bolt the top of the Support Bracket to the **outside** of the plate on the crossmember, **(Figure 10B)**. Make sure that the Support Bracket is as straight up and down and flat against the Bracket as possible. Do not tighten hardware at this time.
  5. Repeat **Steps 2 – 4** for passenger side Bracket installation.
  6. Hold the plastic splash guard up in position against the bottom of the Frame Mounting Brackets, **(Figure 11A)**. Mark the area that needs to be removed from the splash guard to clear the Brackets. Check the location carefully and cut only the minimum amount of plastic from the splash guard to clear the Brackets, **(Figure 11B)**. Once the slots have been checked for clearance, slide the splash guard over the Brackets but do not install the factory hardware-leave cover completely loose.
  7. Select the driver side Sport Bar Mounting Bracket, **(Figures 12 & 13)**. Hold the Bracket up to the outside of the Frame Bracket. Bolt the Sport Bar Bracket to the rear hole in the Frame Bracket with (1) 12mm x 35mm Hex Bolt, (2) 12mm Flat Washers, (1) 12mm Lock Washer and (1) 12mm Hex Nut, **(Figure 14)**.
  8. Line up the lower hole in the Support Bracket with the inside of the Frame Mounting Bracket, **(Figures 12 & 14)**. Insert (1) 12mm x 35mm Hex Bolt and (1) 12mm Flat Washer into the forward hole in the Frame Bracket and through the Sport Bar Bracket and Support Bracket. Secure with (1) 12mm Flat Washer, (1) 12mm Lock Washer and (1) 12mm Hex Nut, **(Figure 14)**. Do not tighten at this time.
  9. Level and adjust the Sport Bar properly and tighten **all** hardware.
  10. Bolt the splash guard in place with the factory hardware.
  11. Do periodic inspections to the installation to make sure that all hardware is secure and tight.

**To protect your investment**, wax this product after installing. Regular waxing is recommended to add a protective layer over the finish. Do not use any type of polish or wax that may contain abrasives that could damage the finish.

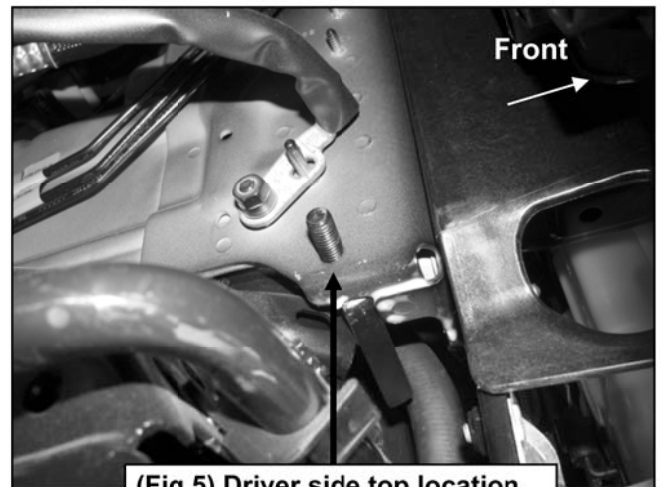
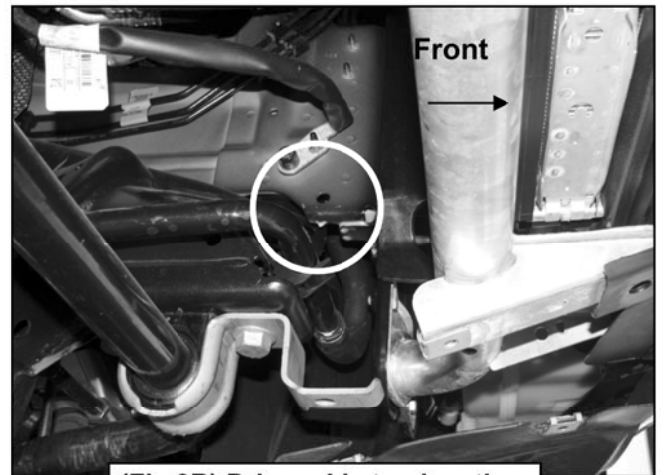
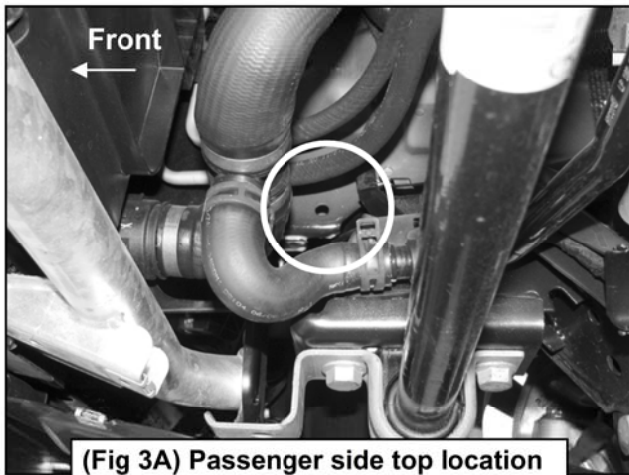
**For stainless steel:** Aluminum polish may be used to polish small scratches and scuffs on the finish. Mild soap may be used also to clean the Sport Bar.

**For gloss black finishes:** Mild soap may be used to clean the Sport Bar.

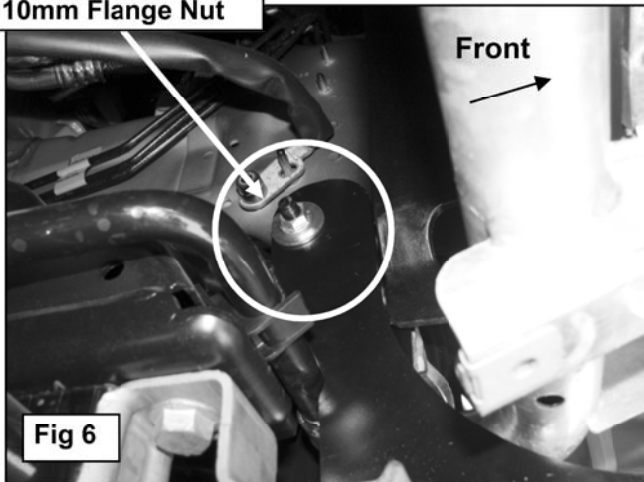
#### DRIVER SIDE INSTALLATION PICTURED



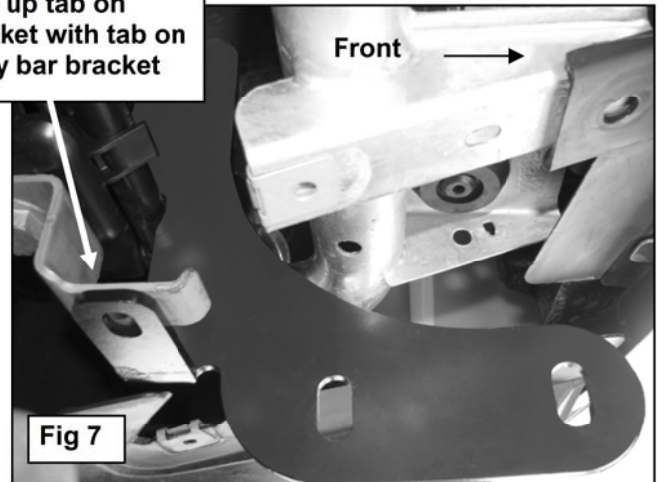
**DRIVER SIDE INSTALLATION PICTURED**



10mm Flat Washer  
10mm Flange Nut

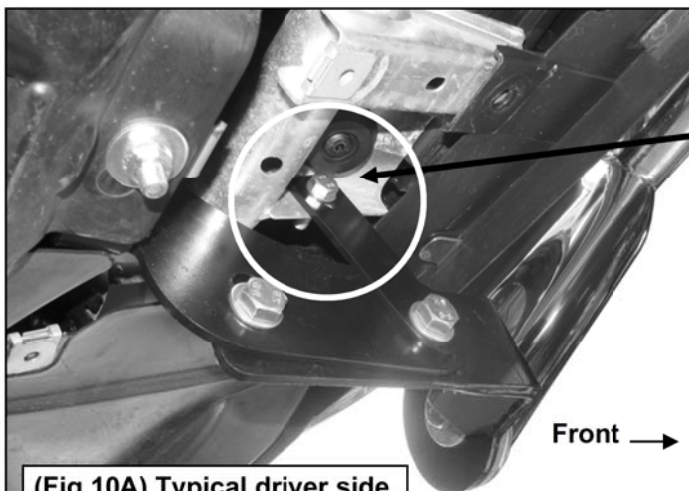
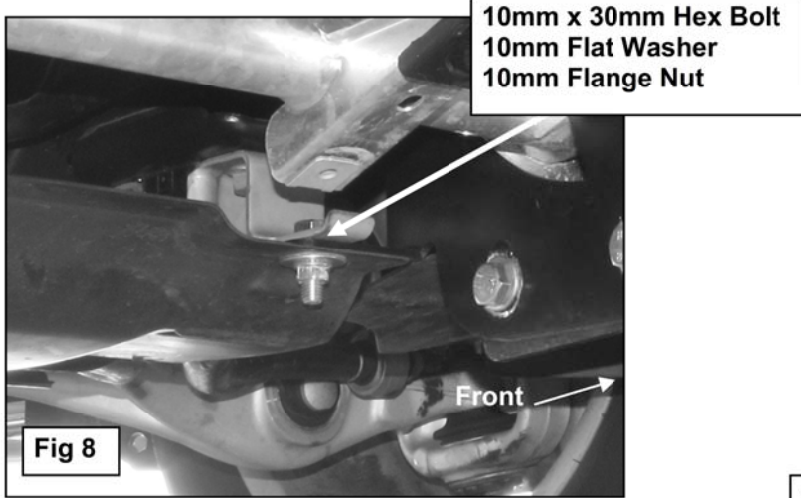


Line up tab on  
bracket with tab on  
sway bar bracket

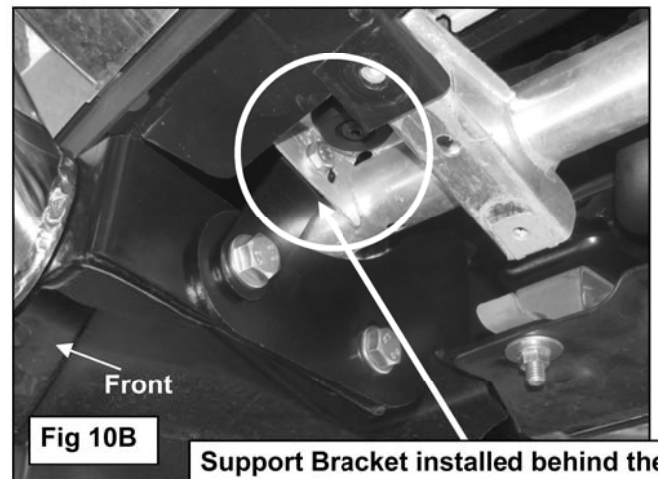




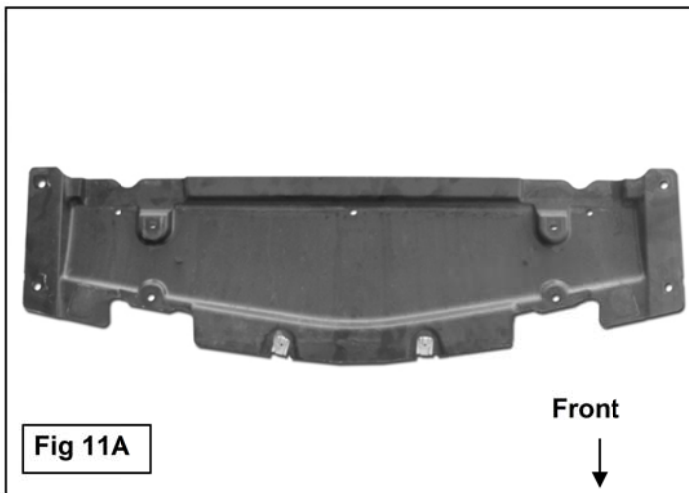
**Driver Side Installation Pictured**



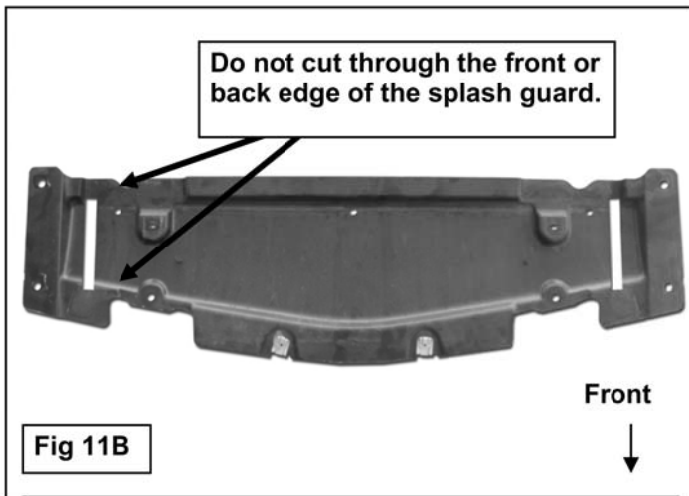
Support Bracket pictured bolted to the inside of the plate on the crossmember. Plate should be as straight up and down as possible. Depending on year and model, it may be necessary to bolt the Support Bracket to either the inside or the outside of the plate on the crossmember. Plastic cover removed for instruction purposes only.



Support Bracket installed behind the plate on the crossmember. Passenger side installation pictured

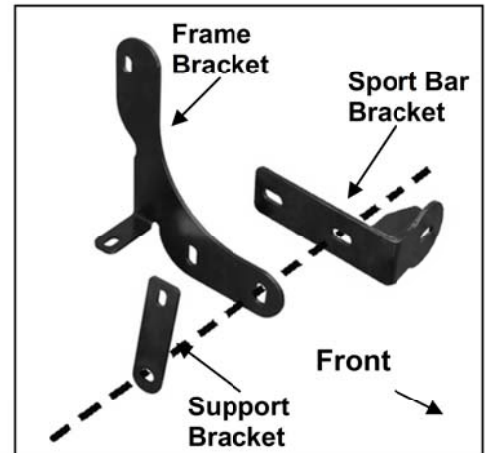


**Driver Side Installation Pictured**

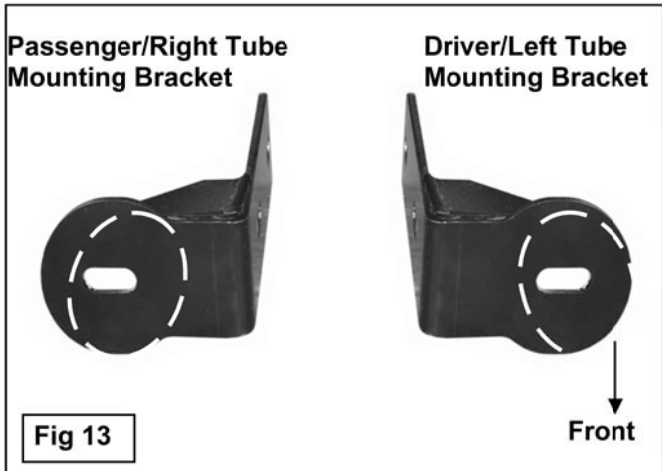


**Fig 11B**

Cut information illustrated for example only. Only remove material required to clear the Brackets



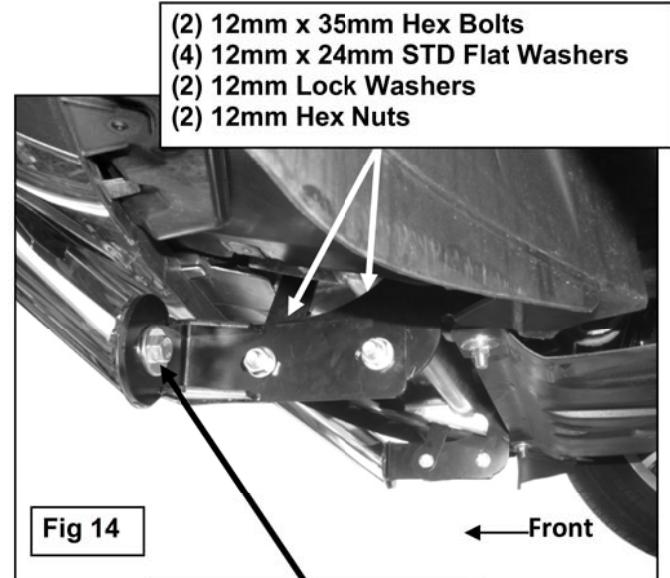
**(Fig 12) Driver side Brackets illustrated**



**Fig 13**



**Complete Installation**



**Fig 14**

12mm x 40mm Hex Bolt  
 12mm Lock Washer  
 12mm x 37mm Large Flat Washer