



INSTALLATION INSTRUCTIONS

BULL BAR PART #BB076010-SP\BB076010A-SP
2002 – 09 DODGE RAM 1500
2003- 09 DODGE RAM 2500/3500

<u>QTY.</u>	<u>ITEM</u>	<u>CONTENT</u>
1	1	BULL BAR
2	2	BRACKETS-PASSENGER & DRIVER SIDE
4	3	RUBBER BUMPER
8	4	3/8" -16 X 1.25" HEX HEAD BOLT
16	5	3/8" FLAT WASHER
8	6	3/8" LOCK WASHERS
8	7	3/8-16 HEX NUT

STEP 1 REMOVE CONTENTS FROM BOX AND VERIFY ALL PART ARE PRESENT. READ INSTRUCTIONS COMPLETELY BEFORE BEGINNING.

STEP 2 IT MAY BE NECESSARY TO REMOVE/RELOCATE FRONT LICENSE PLATE AND LICENSE PLATE BRACKET. IT IS NOT REQUIRED, BUT SRONGLY RECOMMENDED.

STEP 3 DETERMINE PASSENGER AND DRIVER BRACKETS. SEE FIGURE 3. REMOVE TOW HOOKS. KEEP FASTENERS FOR REINSTALLATION.

STEP 4 REMOVAL OF CENTER BUMPER FILLER PANEL IS REQUIRED FOR BRACKET INSTALLATION. FROM BACKSIDE OF BUMPER USE A SMALL SCREWDRIVER TO FIRST PUSH OUT THE CENTER BODY OF RIVET THEN THE MAIN BODY OF RIVET. REMOVE ALL RIVETS AND FILLER PANEL.

STEP 5 LOCATE FOUR HOLES ON FRAME BRACKET. POSITION BRACKETS TO TWO HOLES CLOSEST TO THE OUTSIDE OF VEHICLE. NOTE: 1500 MODELS USE TWO INSIDE SLOTS. 2500/3500 MODELS USE OUTSIDE MOST SLOTS. VEHICLES WITH TOW HOOKS USE FACTORY FASTENERS TO ATTACH BRACKETS, OTHERWISE USE 3/8" FASTENERS. LEAVE LOOSE. SEE FIGURE 3.

STEP 6: ATTACH BULL BAR TO BRACKETS USING 3/8" FASTENERS AS SHOWN. MAKE SURE MOUNT TABS ON HOOP ARE INSIDE BRACKETS. LEAVE LOOSE. SEE FIGURE 3.

STEP 7 LEVEL AND ADJUST BULL BAR AS DESIRED. TORQUE ALL 3/8" FASTENERS TO 30 FT.LBS, AND TOW HOOK FASTENERS TO 65 FT LBS.

4,5,6,7

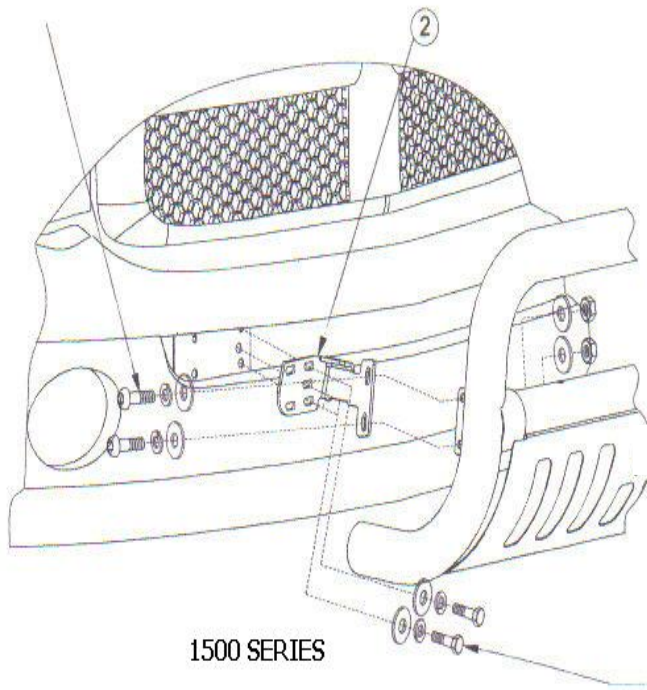

4,5,6,7

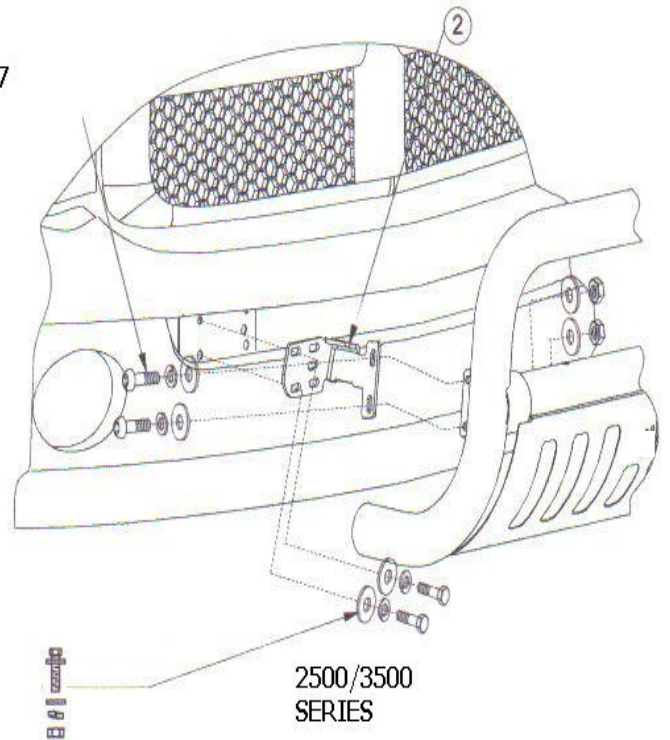

1500 SERIES

4,5,6,7

2500/3500
SERIES

FIGURE 3-INSTALLATION VIEW OF PASSENGER SIDE, DRIVER SIDE OPPOSITE

DODGE RAM