



ELECTRIC SHIFTER INSTRUCTIONS FOR USE ON QUARTER STICK (FRONT EXIT)

Part # QSE

1. Remove the bolts in the rear of the [shifter](#) that mount the shifter to the floor. Install our shifter bracket and solenoid above the base of the shifter (between the mounting bolts and the shifter) using the slotted part of the bracket. Slide the bracket assembly to the back as far as it can go in the slots. Tighten the bolts up that mount the shifter/ bracket assembly to the floor.
2. Put the shifter in 1st gear. Check to make sure that there is about a 1/8" to 1/4" gap between the plunger and the shifter. If necessary, adjust the e-clip to achieve proper gap.
3. Wire the electric solenoid and relay according to our wiring diagram provided below or on the back. If you are using an rpm activator switch not shown, refer to the instructions that came with your rpm activator switch.
4. GO OUT AND WIN A RACE!

WARRANTY

Every unit has been tested prior to shipment, but if failure should occur within 12 months due to faulty equipment, we will repair or replace the defective unit, at Biondo Racings option, free of charge. And Unlike our competition, all parts can be purchased separately.

Biondo Racing Products, inc. shall not be held liable for injury, consequential, or other type of damages resulting from use of it's products This warranty is in lieu of all other warranties of merchantability or fitness of use.

When hooking up this solenoid to our Mega Series delay box or one of Biondo's shift boxes, follow this diagram.

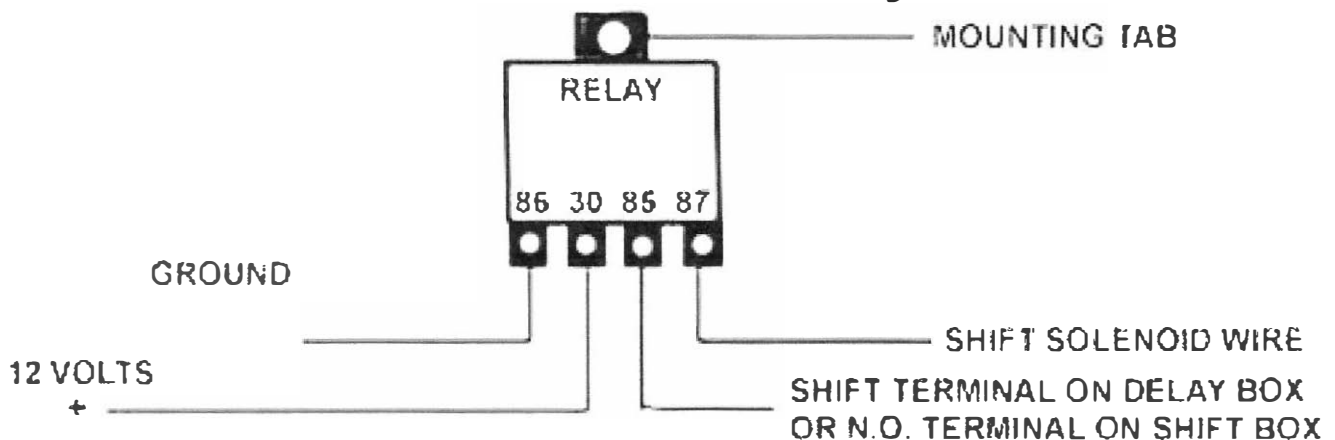

MSD RPM SWITCH

(NOT USED) GRAY

TO SWITCHED 12V RED

TO TACH TERMINAL ON MSD WHITE

TO MSD CASE GROUND BLACK

YELLOW

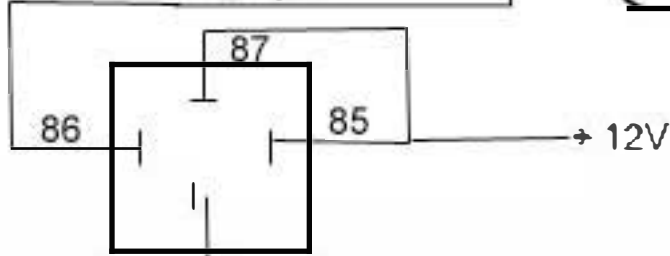

ELECT-A-SHIFT
RELAY

TO EITHER ELECTRIC SOLENOID WIRE
THE SOLENOID HAS NO POLARITY

MSD DIGITAL 7

TO EITHER ELECTRIC SOLENOID WIRE
THE SOLENOID HAS NO POLARITY

BROWN/WHITE

12V SWITCHED

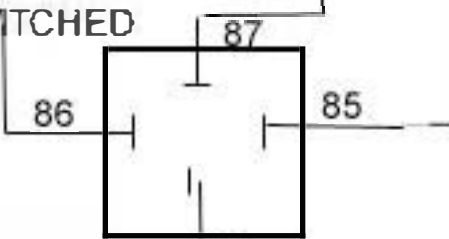

ELECT-A-SHIFT
RELAY

12V DIRECT



MANUALLY

TO GROUND
NEGATIVE

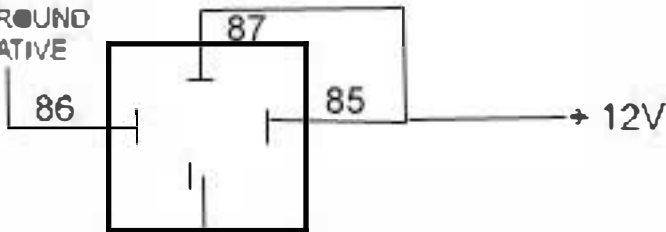

ELECT-A-SHIFT
RELAY

TO EITHER ELECTRIC SOLENOID WIRE
THE SOLENOID HAS NO POLARITY

Wiring Electric Shifter Solenoids

Many electric solenoids used on today's race car shifters draw high amperage. Therefore common wiring mistakes tend to show up as technical issues. Proper wiring and installation will make your solenoid more reliable and last longer.

These instructions are generic and will not address all issues relative to specific models. There are many issues unique to each solenoid kit that can cause technical issues such as a weak solenoid, a solenoid that does not complete a shift, or a solenoid with a short life. Refer to the instructions specific to your brand and model.

High amperage solenoids, typically solenoids that do not use a spring to do the shifting, may draw from 24 to as much as 40 amps. Because of this amperage requirement it is important to supply sufficient power and ground to avoid a weak or overheating solenoid.

One wire solenoids will have one wire or terminal for the Hot side of the circuit. They will Ground through the bracket they are attached to.

Two wire solenoids will have one wire or terminal for Ground and one wire or terminal for the Hot side of the circuit.

Two wire Spring activated solenoids have a spring on the front that pushes the shifter and will have one wire or terminal for Ground and one wire or terminal for the Hot side of the circuit.

Wiring One Wire, High Amperage Solenoids:

It is important that this style of solenoid be activated by a Normally Open Circuit, (N.O.) from your RPM switch or Timer. Through a relay, they can be wired to be activated by N.O. Ground or N.O. Power. Refer to the instructions specific to your brand and model. For a high amperage one wire solenoid installation always use a relay of correct size and supply a 12 Volt wire, a minimum of 12 AWG, from a suitable power source to a relay line terminal and from the relay load terminal to the Hot terminal on the solenoid. For the additional wires needed on the relay, refer to the instructions specific to your make and model.

This supply wire should originate from the switched side of the battery disconnect switch. Running this wire from a typical fuse block, stud, or power supply point will many times be a problem. These power supply points may not be capable of supplying the needed amperage when everything on that point is activated at the same time.

On a one wire solenoid the bracket must be grounded properly to the chassis. In most cases bolting the bracket down will supply a sufficient ground but many times painted or powder coated floors or removable shifter platforms that are pinned in place will supply a insufficient, weak ground. A poor ground will cause the same problems as a poor power

supply. This can cause a solenoid to be weak and or overheating, resulting in very short life. If in doubt add a wire from the shifter, solenoid, or solenoid bracket and connect to a good chassis ground.

Wiring Two Wire, High Amperage Solenoids:

It is important that this style of solenoid be activated by a Normally Open Circuit, (N.O.) from your RPM switch or Timer. Through a relay, they can be wired to be activated by N.O. Ground or N.O. power. Refer to the instructions specific to your brand and model. For a high amperage two wire solenoid installation always use a relay of correct size and supply a 12 Volt wire, a minimum of 12 AWG, from a suitable power source to a relay line terminal and from the relay load terminal to the Hot, typically Red wire, on the solenoid. For the additional wires needed on the relay, refer to the instructions specific to your make and model.

This supply wire should originate from the switched side of the battery disconnect switch. Running this wire from a typical fuse block, stud, or power supply point will many times be a problem. These power supply points may not be capable of supplying the needed amperage when everything on that point is activated at the same time. On a two wire solenoid, Ground the remaining wire, typically Black, to a good chassis ground.

Wiring Two Wire, Spring shift, Low Amperage Solenoids:

If your RPM switch or Timer supplies a Normally Closed GROUND (N.C.) circuit, supply a 12 Volt wire, a minimum of 14 AWG, from a suitable power source to the Hot, typically Red wire, on a two wire spring solenoid. This wire should originate from the switched side of the battery disconnect switch and through a ON / OFF switch that can be used to turn the solenoid power off when not in use.

The remaining wire, typically Black, will connect to the (N.C.) terminal on your RPM Switch or Timer.

If your RPM switch or Timer supplies a Normally Closed POWER (N.C.) circuit, connect wire, a minimum of 14 AWG, from the N.C. terminal or wire on your RPM Switch or Timer, to the Hot, typically Red wire, on a two wire spring solenoid. This wire should pass through a ON / OFF switch that can be used to turn the solenoid power off when not in use.

The remaining wire, typically Black, should connect to a good chassis ground.

Testing:

If using a RPM switch it is not necessary to run the engine to test most Electric or Air shifters. After installation is complete, turn on all power and place your shifter in first gear. If wired properly, the RPM switch will send or remove, power or ground when the engine is accelerated to the preset RPM. This can be simulated by removing a wire or by using a jumper wire from power or ground to the relay, based on the model of RPM switch used.

If your RPM switch supplies NORMALLY OPEN GROUND, (N.O. GROUND), touch a jumper wire from a good chassis ground to the terminal on the relay your RPM switch connects to. The solenoid should now activate. Remove wire immediately. Do not leave this wire connected for more than a few seconds at a time.

If your RPM switch supplies NORMALLY OPEN POWER, (N.O. 12V+), touch a jumper wire from a known power supply to the terminal on the relay your RPM switch connects to. The solenoid should now activate. Remove wire immediately. Do not leave this wire connected for more than a few seconds at a time.

If your RPM switch supplies NORMALLY CLOSED GROUND, (N.C. GROUND), Remove or disconnect the wire from the RPM switch to the solenoid. This method is used with SPRING shifters. The spring should now be released and shift your shifter.

WARNING !

If Activating A Solenoid With A RPM Switch Or Timer:

If using a RPM switch or timer, you must be aware that at any time, Radio Frequency Interference, (RFI), could stop the switch or timer from activating. This, in turn, could cause your automatic shifter to not activate and you will need to shift manually. Always be aware of the engine RPMs and be prepared to shift manually or decelerate to prevent over acceleration of your engine. All cars using a RPM switch or Timer MUST be protected with some type of electronic or mechanical over rev protection.

Modifying The Shifter:

In order to utilize the maximum efficiency of automated shifter activators, minor modifications may need to be made to various shifters. Be aware that modifying any brand of shifter may void the manufactures warranty. Once a shifter has been modified, the ability to receive warranty service or to return a shifter may be impaired. You must assume all responsibility for any modifications.