

- **BMW M5 Sedan DampTronic** -



- **mounting instruction**

**Before installation please observe
the following points:**

- Read all information in this manual carefully.
- All suspension components are fitted and removed acc. to the manufacturer's specifications for installing and removal, if not otherwise required in these instructions.

- Check that your vehicle type is listed in the certificate as being specified for this kit.

- Check the product for all components before starting installation!
- Check that dimensions and fastening points are comparable between the original and BILSTEIN shock absorbers.
- Directional references (left, right, front, rear) are always with reference to the driving direction.
- Remove the negative battery pole.
- The tested vehicles are left- hand drive vehicles.

**After installation please observe
the following points:**

- Set the vehicle height by adjusting spring plates and lock nuts on the new dampers. Only use the supplied spanner wrenches.

- All rubber- mounted strut/ damper attachments must not be fully tightened until AFTER the suspension system is loaded (wheels on the ground). Other mounting fasteners (for example brackets) must be securely tightened BEFORE load is placed on the suspension system.
- Because the vehicle has been lowered, freedom of movement for all wheel-/ tire- combinations must be checked.
- Connect the negative battery pole.
- After installing the suspension system, caster and camber must be checked and adjusted according to manufacturer's specifications.
- Check and reset load- dependent brake compensator and ABS system according to manufacturer's specifications.
- Check and adjust headlight setting.

All diagrams are generalized
and not to scale!
brackets, etc. specific to
strut are not shown!

list of torques

Thread	M8	M 10	M 12	M 14	M 16
Torque Nm	13	25	45	72	110
Torque ft lb	10	19	34	54	83

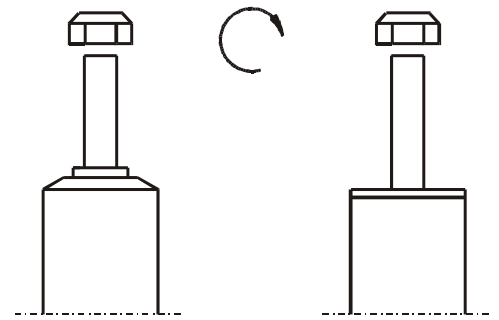

Do not use an impact tool to loosen or tighten fasteners due to possible damage to the product.
Self- locking nuts must only be used once!

Removal

Place vehicle on a wheel- free car hoist,
lift it and remove wheels.

Vehicles equipped **with xenon headlight** the movable element of sensor for the headlamp levelling controller must removed before.

Pay attention that support wires of brake system are strain-free during removal. Stabilization by suitable means is demanded.

Remove bottom mounting.

If necessary release brake hose/ brake hose holder/ stabilizer/ ABS- hose and/ or swing- support at strut.

Detach cable connection from dome inside engine compartment. Remove plastic cover and remove cable connection from strut.

Remove top fixing nuts from support bearing.
Do not remove central nut at this time!

Remove complete strut and clamp it in an appropriate strut vice.

Using a suitable spring compressor, compress suspension spring until support bearing is free to move.

Release centre nut and remove original mounting parts and coil spring. Please refer to diagram to identify which parts will be replaced with BILSTEIN- supplied components.

Installing

Fit original/ BILSTEIN mounting parts on strut in reverse order as removal.

The original spring pad must be reused!

Do not reuse original- bumper, since BILSTEIN- strut has built in bump stop.

Fit assembled BILSTEIN strut to the vehicle in reverse order as removal.

Installation of cable harness for front axle

Clip the BILSTEIN adapter wire together with the plug housing to cover of suspension dome.



Route the wire along the lateral splash wall (arrow) to an accessible cutout into wheel house and fix it with sufficient cable clips.

To make the wire routing easier it is recommended removing the wheelhouse protector before fitting.

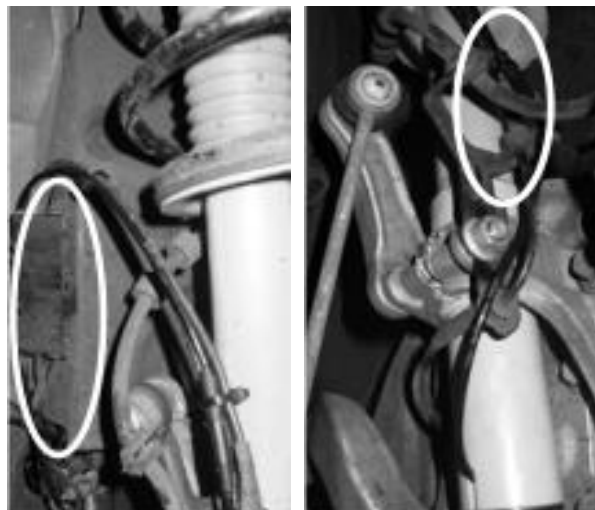

Route the adapter wire through the on-board plug house, along the ABS wire down to the shock absorber and fix it with cable clips. Connect the plug and socket of the shock absorber with the adapter wire harness and fix it properly.

The cable routing on passengers side is to be done in reverse order to the other side.

front axle left/ right

OE = Original Equipment

B = Delivered by BILSTEIN

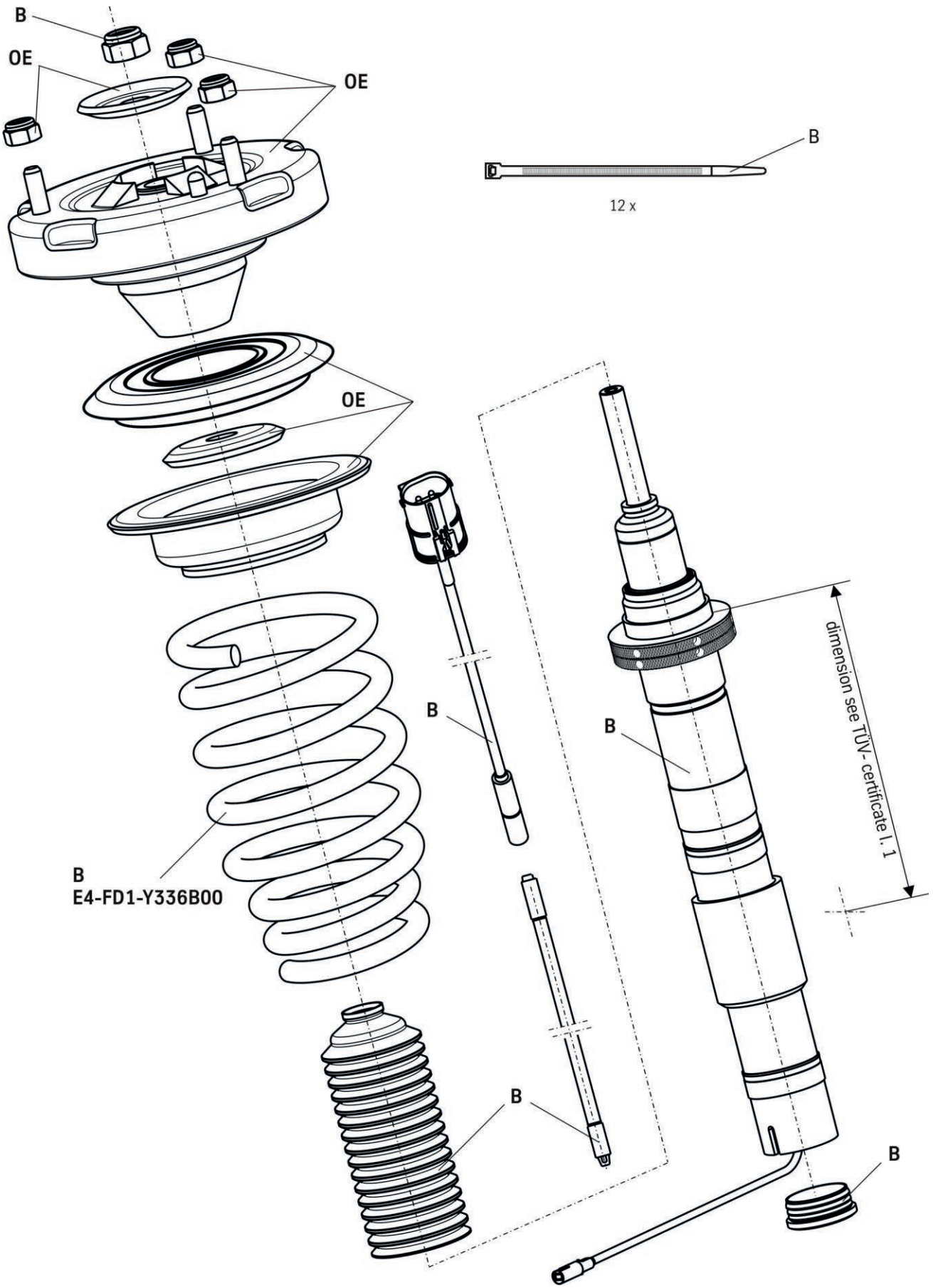

mounting instruction for rear axle

Removal

Place vehicle on a wheel-free-car hoist, lift it and remove wheels.

Vehicles equipped **with xenon headlight** the movable element of sensor for the headlamp levelling controller must removed before.

Pay attention that support wires of brake system are strain-free during removal. Stabilization by suitable means is demanded.

Remove bottom mount.

If necessary release brake hose/ brake hose holder/ stabilizer/ ABS- hose and/ or swing-support at strut.

Remove top fixing nuts from support bearing.

Do not remove piston rod nut!

Remove complete strut and clamp it in an appropriate strut vice.

Using a suitable, licensed spring compressor, compress suspension spring until tension on support bearing is free to move.

Release centre nut and remove original mounting parts and coil spring. Please refer to diagram to identify which parts will be replaced with BILSTEIN- supplied components.

Installing

Assemble BILSTEIN and/ or original mounting parts, as well as the spring on the BILSTEIN strut in reverse order to removal.

Fit assembled BILSTEIN strut to the vehicle in reverse order to removal.

Installation of the cable harness for rear axle

Connect the shock absorber wire together with the adapter wire along the vehicles harness to the standard plug.



OE = Original Equipment

B = Delivered by BILSTEIN

