



**Before installation please observe
the following points:**

- Read all information in this manual carefully. -
All suspension components are fitted and removed acc. to the manufacturer's specifications for installing and removal, if not otherwise required in these instructions.

- Check that your vehicle type is listed in the certificate as being specified for this kit. -
Vehicles that are equipped with PDCC, the BILSTEIN service kit 11-223900 is requested additional!

- Check the product for all components before starting installation! -

- Check that dimensions and fastening points are comparable between the original and Bilstein shock absorbers. -

- Directional references (left, right, front, rear) are always with reference to the driving direction. -
Remove the negative battery pole. -

- The tested vehicles are left- hand drive vehicles. -

**After installation please observe
the following points:**

- Set the vehicle height by adjusting spring plates and lock nuts on the new dampers. Only use the supplied spanner wrenches. -

- All rubber- mounted strut/ damper attachments must not be fully tightened until AFTER the suspension system is loaded (wheels on the ground). Other mounting fasteners (for example brackets) must be securely tightened BEFORE load is placed on the suspension system. -

- Because the vehicle has been lowered, freedom of movement for all wheel/ tire- combinations must be checked. -

- Connect the negative battery pole. -

- After installing the suspension system, caster and camber must be checked and adjusted according to manufacturer's specifications. -

- Check and reset load- dependent brake compensator and ABS system according to manufacturer's specifications. -

- Check and adjust headlight setting. -



All diagrams are generalized
and not to scale!
brackets, etc. specific to
strut are not shown!

instruction for force adjustment

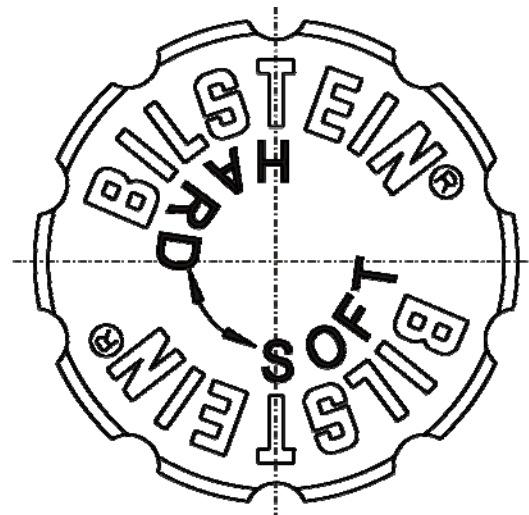
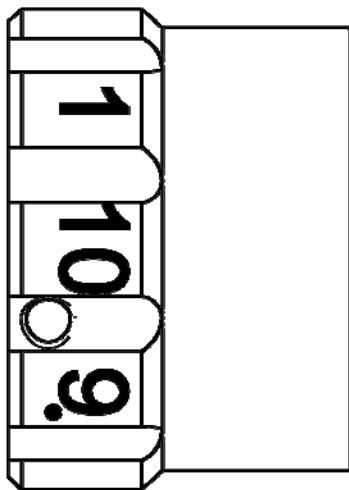

position **1** = **comfort**

position **10** = **sport**

During the adjustment you will hear a positive „click“ at each position of the adjustment.

Instruction for the front axle

The adjusting element of the front struts is located at the bottom end of the strut.

Adjusting position must aligned with the red mark on outer tube.

Status of delivery is position **1**.

list of torques					
	M8	M 10	M 12	M 14	M 16
Thread					
Torque Nm	13	25	45	72	110
Torque ft lb	10	19	34	54	83

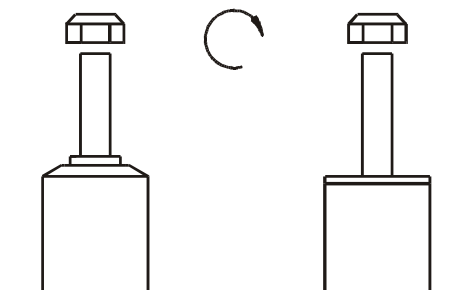

Do not use an impact tool to loosen or tighten fasteners due to possible damage to the product.
Self- locking nuts must only be used once!

Remove strut

Place vehicle on a wheel-free car hoist, lift it and remove wheels.

Vehicles equipped with xenon headlight the sensor for the headlamp levelling controller must removed before.



The lower control arm must be supported by suitable means!

Remove bottom mounting.

Remove top fixing nuts from support bearing.

Do not remove central nut at this time!

Remove complete strut and clamp it in an appropriate strut vice.

Using a suitable spring compressor, compress suspension spring until tension on support bearing is free to move.

Release central nut and remove original mounting parts and coil spring. Please refer to diagram to identify which parts will be replaced with BILSTEIN- supplied components.

Installing strut

Assemble BILSTEIN and/ or original mounting parts, as well as the new BILSTEIN spring on the BILSTEIN strut in reverse order as removal.



IMPORTANT! Spring plates must not be adjusted outside the ranges specified in the certificate!

The correct mounting position of the suspension springs can be determined by the printing on the springs; install them with the print upright.

Fit assembled BILSTEIN strut to the vehicle in reverse order as removal.

The cable for the electronic force adjustment can be fixed along the ABS- cable to connect with original plug adapter.

All rubber- mounted strut/ damper attachments must not be fully tightened until AFTER the suspension system is loaded (wheels on the ground). Other mounting fasteners (for example brackets) must be securely tightened BEFORE load is placed on the suspension system. Make sure that the bump stop and dust cover are correctly and properly fastened.

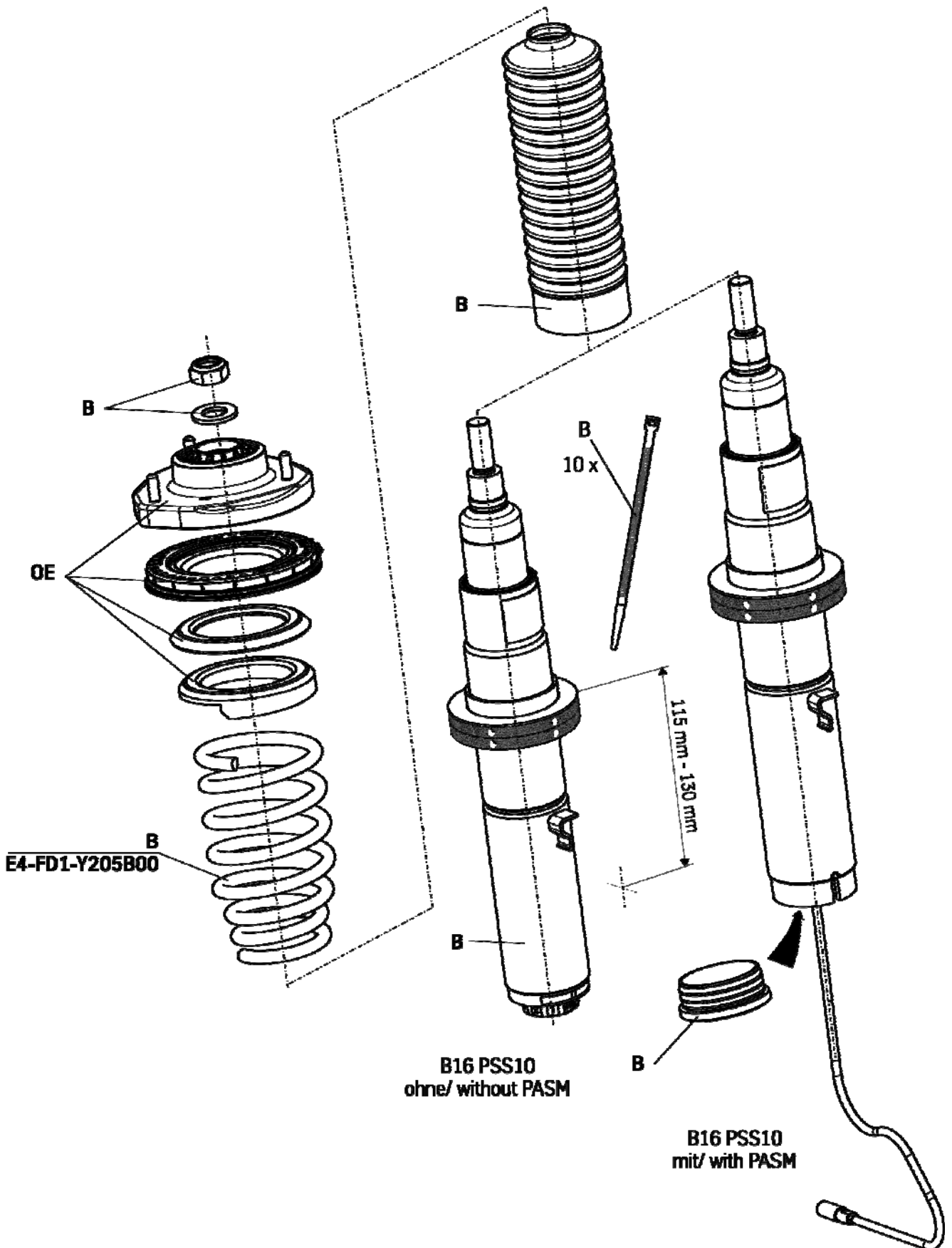

Removal shock absorber

Place vehicle on a wheel- free car hoist, lift it and remove wheels.

Vehicles equipped with xenon headlight the sensor for the headlamp levelling controller must removed before.



The lower control arm must be supported by suitable means!

Remove bottom mounting.

Remove top fixing nuts from support bearing.

Do not remove central nuts at this time!

Remove complete shock absorber and clamp it in an appropriate strut vice.

Using a suitable spring compressor, compress suspension spring until tension on support bearing is free to move.

Release central nut and remove original mounting parts and coil spring. Please refer to diagram to identify which parts will be replaced with BILSTEIN- supplied components.

PSS10- 10 step- pin adjustment

The adjustment unit must be deinstall before the shock absorber installation can be completed in reverse order as before with BILSTEIN and/ or original mounting parts.

- A- Set screw
- B- Adjusting head
- C- lock nut M12x 1
- D- End stop disc
- E- Nut M12x1
- F- Support ring
- G Set screw
- H End stop pin
- I Adjusting screw
- J disc

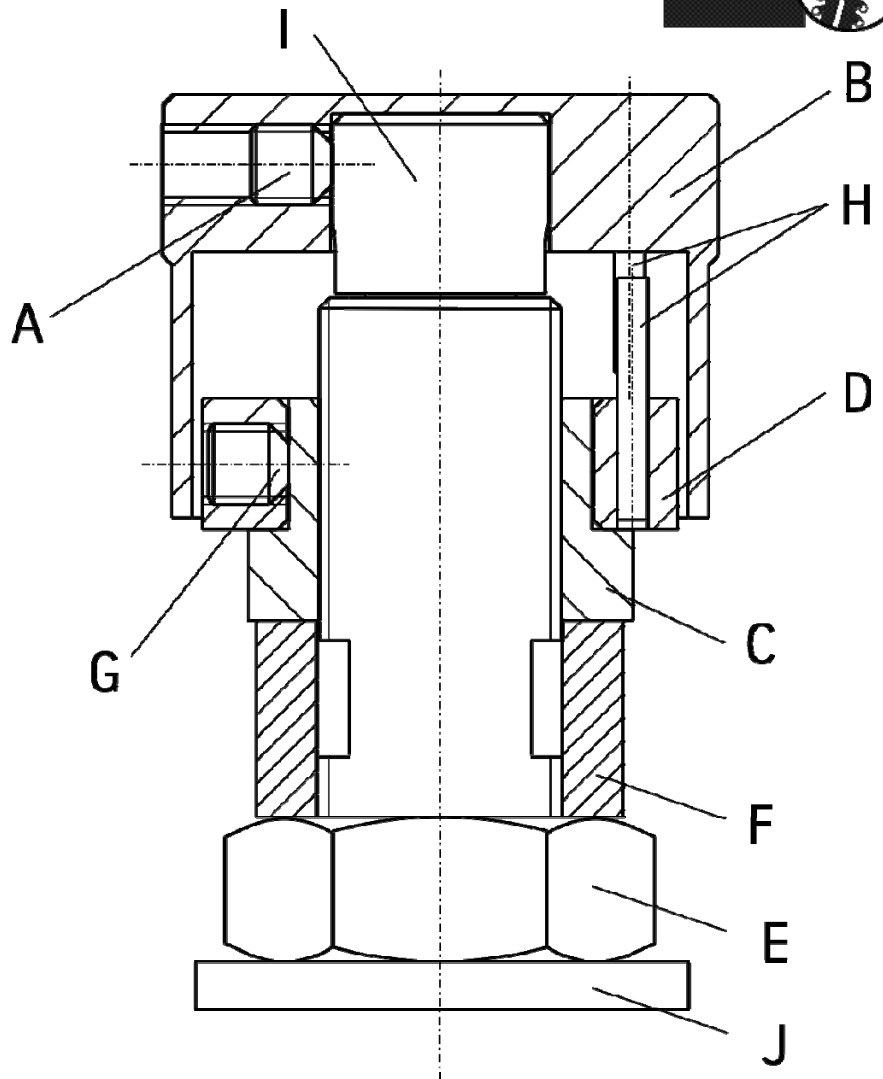

position **1** = **comfort**
 (counter-clockwise direction)
 position **10** = **sport**
 (clockwise direction)

Instruction for the rear axle
 Status of delivery is position **10**.



Removal Adjustment Unit PSS10

(see sketches on page 19/21)

To remove the adjusting head (B) the set screw (A) must loose.

Remove end stop disc (D) together with lock nut (C). Remove support ring (F) as well as nut (E) and disc (J).

Now remove all original mounting parts and fit Bilstein and/ or original mounting parts in reverse order as removal.

Installing Adjustment Unit PSS10

After installing support bearing the disc (J) must fit. Tighten nut (E) with support ring (F) to block. Tighten lock nut (C).

Pins (H) are end stops.

Place the adjusting knob (A) flat on the adjusting screw (I) and turn it clockwise to end stop.

Fix the adjusting head (B) with set screw (A).

The adjusting head should move easily and with distinct “clicks” at each adjustment position. If not, disassemble the adjustment unit and reassemble acc. to the instruction.

Installing shock absorber

Assemble BILSTEIN and/ or original mounting parts, as well as the new BILSTEIN spring on the BILSTEIN strut in reverse order as removal.

IMPORTANT! Spring plates must not be adjusted outside the ranges specified in the certificate!

Fit assembled shock absorber to the vehicle in reverse order as removal.

The cable harness above the adjustment must be protected against damages by using appropriate aids.

