

position **9** = **soft** ( clockwise direction)  
 position **1** = **firm** ( counter- clockwise direction)

During the adjustment you will hear a positive „click“ at each position of the adjustment.

**Instruction for the front axle**

The adjusting element of the front struts is located at the bottom edge of the strut, covered by a blue plastic cap. That cap must be removed before adjusting. After the adjustment the cap must be replaced again.

- **list of torques**

	M8	M 10	M 12	M 14	M 16	Thread
	13	25	45	72	110	Torque Nm
	10	19	34	54	83	Torque ft lb

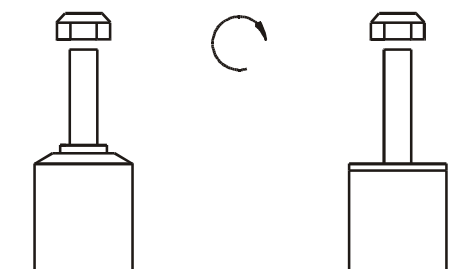

## Remove strut

Place vehicle on a chassis hoist, lift it and remove wheels.

Vehicles equipped with xenon headlight the sensor for the headlamp levelling controller must removed before.



***The lower control arm must be supported by suitable means!***

Remove bottom mount.

Remove top fixing nut from support bearing. Do not remove centre nut at this time!

Remove complete strut and clamp it in an appropriate strut vice.

Using a suitable spring compressor, compress suspension spring until tension on support bearing is released.

Release centre nut and remove original mounting parts and coil spring. Please refer to diagram to identify which parts will be replaced with BILSTEIN- supplied components.

## Install strut

Assemble BILSTEIN and/ or original mounting parts, as well as the new BILSTEIN spring on the BILSTEIN strut in reverse sequence of removal.



***IMPORTANT! Spring plates must not be adjusted outside the ranges specified below!***

The correct mounting position of the suspension springs can be determined by the printing on the springs; install them with the print upright.

Fit assembled BILSTEIN strut to the vehicle in reverse sequence to removal.

The cable for the electronic force adjustment must be fixed by stick- cable clip (1x) at pos. **A**. With small cable clips (10x) the electronic cable can be fixed along the ABS- cable to connect with original plug adapter.

All rubber- mounted strut/ damper attachments must not be fully tightened until AFTER the suspension system is loaded (wheels on the ground). Other mounting fasteners (for example brackets) must be securely tightened BEFORE load is placed on the suspension system. Make sure that the bump stop and dust cover are correctly and properly fastened.

**B** = BILSTEIN Lieferumfang  
Delivered by BILSTEIN

**OE** = Original Anbauteile  
Original Equipment

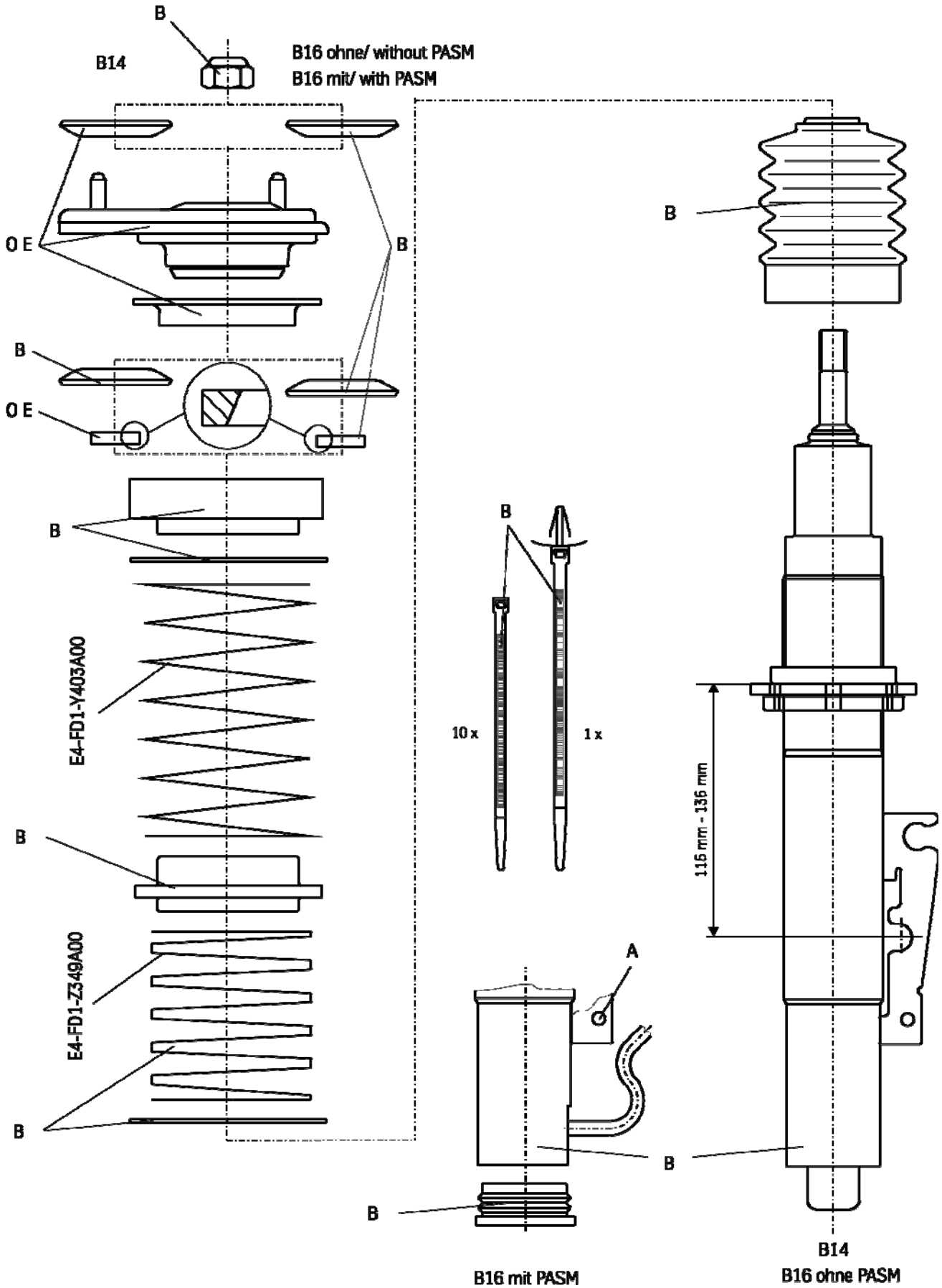

## Remove shock absorber

Place vehicle on a chassis hoist, lift it and remove wheels.



***When the vehicle is equipped with Bose- Sound- System the soundboard must be removed for reaching the adjustment of B16.***

***The lower control arm must be supported by suitable means!***

Remove bottom mount.

Remove top fixing nuts from support bearing.  
Do not remove centre nut at this time!

Remove complete shock absorber and clamp it in an appropriate strut vice.

Compress suspension spring until tension on support bearing is released.

Release centre nut and remove original mounting parts and coil spring. Please refer to diagram to identify which parts will be replaced with BILSTEIN- supplied components.

Original rubber spring pad at rear axle must be replaced by Bilstein part.

## B16- 9 step- pin adjustment

The preassembled adjustment unit must first be dismantled again, before the BILSTEIN shock absorber can be completed.

- A- adjusting knob
- B- set screw
- C- adjusting head
- D- M12x 1 counter nut
- E- adjusting pin
- F- square rod stop
- G- spring- loaded detent ball

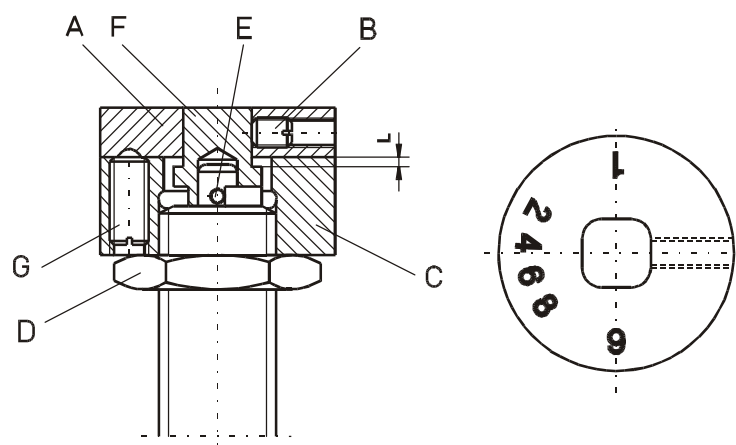

position **9** = **soft** ( clockwise direction)  
position **1** = **firm** ( counter- clockwise direction)

## Disassembly B16

The adjusting knob ( A ) must be positioned on 9 ( see sketch ).

Loosen the set screw ( B ) by an 1,5 mm hex key and remove the adjusting plate.

Hold the adjusting head ( C ) with an appropriate tool ( SW 21 spanner ), and loosen the lock nut ( D ; SW 17 ).

Now the adjusting head and lock nut can be removed, to install the shock absorber.

The installation of the shock absorbers must be done according to the mounting instructions.

Improper installation will render the adjustment function inoperative!!

## Assembly B16

The square rod stop ( F ) must be turned in clockwise direction fully to its stop ( soft ).

Assemble first the lock nut, then the adjusting head. Do not thread the top of the adjusting head ( C ) past the stop at the bottom edge of the square section ( F ). A gap ( L ) of 0 to 1 mm is necessary!

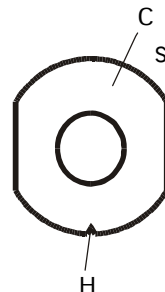

Orient the score mark ( H ) on adjusting head in the centre of any of the four sides of the square rod stop. Then lock the parts together by screwing the lock nut up to the adjuster head.

The adjusting knob ( A ) must be placed flat on the adjusting head, so that the spring-loaded detent ball ( G ) is slightly preloaded. During adjustment the ball must snap with a positive „click“ into the notches on the lower side of the knob.

Position 9 must be positioned directly above the score mark on the adjusting head ( C ). Then tighten the set screw ( B ).

The adjusting knob ( A ) should move easily and with distinct „clicks“ at each adjustment position. If not, disassemble the adjuster mechanism and reassemble according to the instructions

## Installing shock absorber

Assemble BILSTEIN and/ or original mounting parts, as well as the new BILSTEIN spring on the BILSTEIN strut in reverse sequence of removal.



**IMPORTANT! Spring plates must not be adjusted outside the ranges specified below!**

The correct mounting position of the suspension springs can be determined by the printing on the springs; install them with the print upright.

Fit assembled shock absorber to the vehicle in reverse sequence of removal.

**B =** BILSTEIN Lieferumfang  
Delivered by BILSTEIN

**OE =** Original Anbauteile  
Original Equipment

