



**Before installation please observe
the following points:**

- Read all information in this manual carefully.
All suspension components are fitted and removed acc. to the manufacturer's specifications for installing and removal, if not otherwise required in these instructions.

- Check that your vehicle type is listed in the certificate as being specified for this kit.

- Check the product for all components before starting installation!

- Check that dimensions and fastening points are comparable between the original and Bilstein shock absorbers.

- Directional references (left, right, front, rear) are always with reference to the driving direction.

- Remove the negative battery pole.

- The test vehicles are left- hand drive vehicles.

**After installation please observe
the following points:**

- Set the vehicle height by adjusting spring plates and lock nuts on the new dampers. Only use the supplied spanner wrenches.

- All rubber- mounted strut/ damper attachments must not be fully tightened until AFTER the suspension system is loaded (wheels on the ground). Other mounting fasteners (for example brackets) must be securely tightened BEFORE load is placed on the suspension system.

- Because the vehicle has been lowered, freedom of movement (clearance) for all wheel-/ tire- combinations must be checked.

- Connect the negative battery pole.

- After installing the suspension system, caster and camber must be checked and adjusted according to manufacturer's specifications.

- Check and reset load- dependent brake compensator and ABS system according to manufacturer's specifications.

- Check and adjust headlight setting.

All diagrams are generalized
and not to scale!
Brackets, etc. specific to
strut are not shown!

instruction for force adjustment

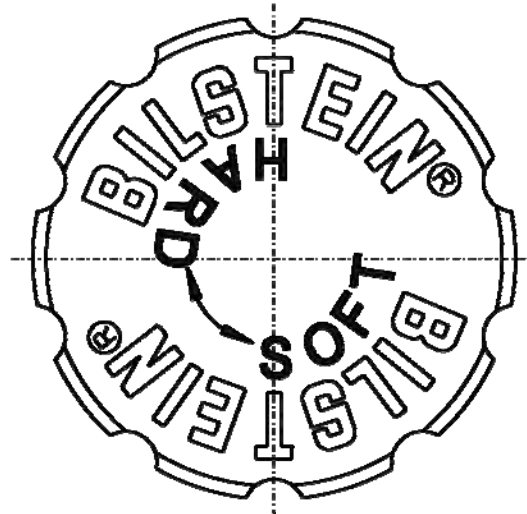
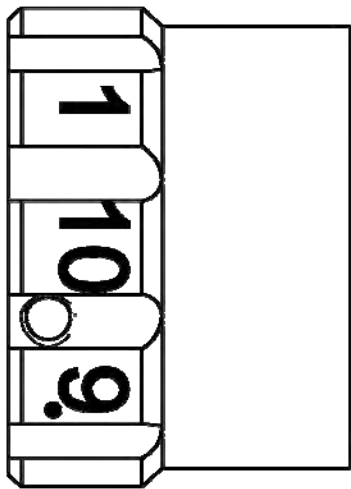

position **1** = **comfort**
 position **10** = **sport**

During the adjustment you will hear a positive „click“ at each position of the adjustment.

Instruction for the front and rear axle

Status of delivery is position **1**.

The adjusting element is located at the bottom edge of the strut.

Position **1** must aligned with the red mark.

Take care that the adjustment position is the same on both sides of vehicle (left/ right).

- list of torques

| | M8 | M 10 | M 12 | M 14 | M 16 | Thread |
|--|----|------|------|------|------|--------------|
| | 13 | 25 | 45 | 72 | 110 | Torque Nm |
| | 10 | 19 | 34 | 54 | 83 | Torque ft lb |

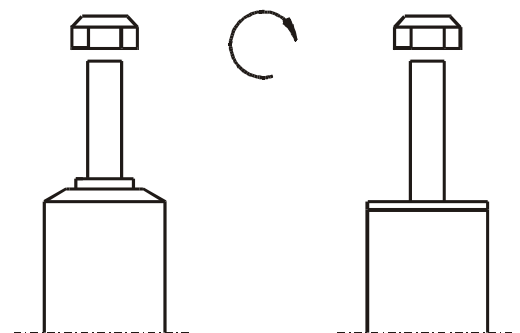

Do not use an impact tool to loosen or tighten fasteners due to possible damage to the product.
Self- locking nuts must only be used once!

Removal

Place vehicle on a wheel- free car hoist, lift it and remove wheels.

Vehicles equipped **with xenon headlight** the movable element of sensor for the headlamp levelling controller must removed before.



The lower control arm must be supported by suitable means!

Remove bottom mounting.

Remove top fixing nuts from support bearing.
Do not remove central nut at this time!

Remove complete strut and clamp it in an appropriate strut vice.

Using a suitable spring compressor, compress suspension spring until tension on support bearing is free to move.

Release central nut and remove original mounting parts and coil spring. Please refer to diagram to identify which parts will be replaced with BILSTEIN- supplied components.

ATTENTION: If the original brake hose holder can not fitted because of lack space, it is to cut as shown on **pic. 1 and 2**. Finally the holder can be taped by cable ties (parts of delivery) as shown on **pic. 3**.



Installing

Assemble BILSTEIN and/ or original mounting parts, as well as the new BILSTEIN spring on the BILSTEIN strut in reverse order as removal.

IMPORTANT! Spring plates must not be adjusted outside the ranges specified in certificate!

The correct mounting position of the suspension springs can be determined by the printing on the springs; install them with the print upright.

Do not reuse original dust cover and original- bumper, since BILSTEIN- strut has built in bump stop.

Fit assembled BILSTEIN strut to the vehicle in reverse order as removal.

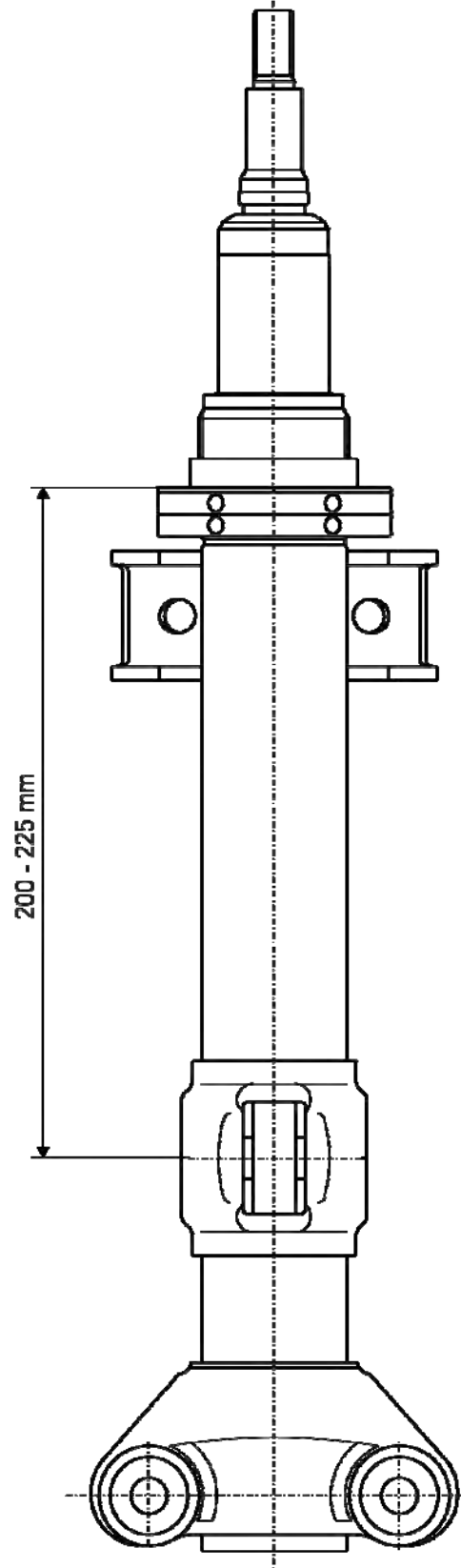
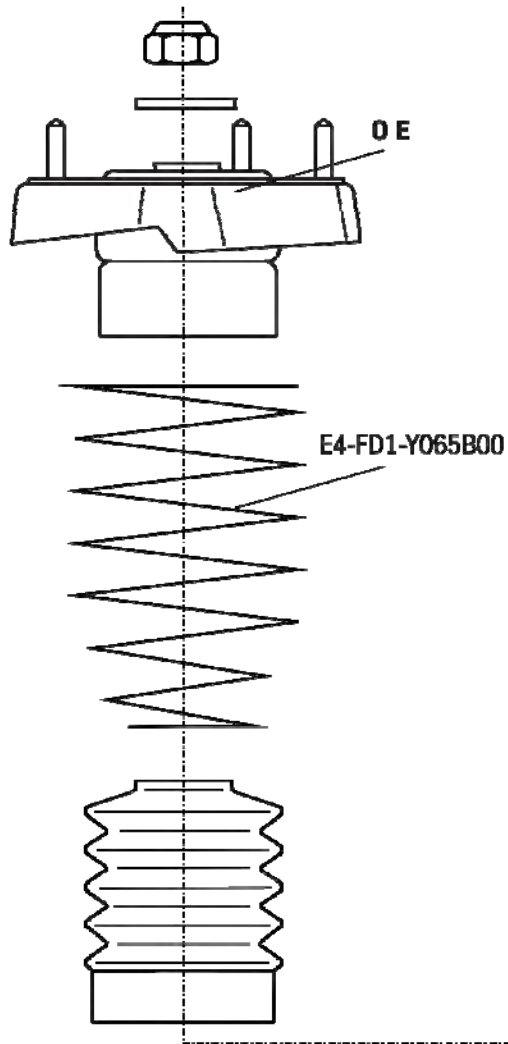

OE = Original Anbauteile
Original Equipment



mounting instruction for rear axle

Removal

Place vehicle on a wheel- free car hoist,
lift it and remove wheels.



The lower control arm must be supported by suitable means!

Remove top and bottom
mounting from support bearing.

Remove shock absorber and
original mounting parts.

Installing

Fit BILSTEIN and/ or original mounting
parts in BILSTEIN shock absorber in
reverse order as removal.

Do not reuse original dust cover
and original bumper.

Fit BILSTEIN shock absorber to the vehicle
in reverse order as removal.

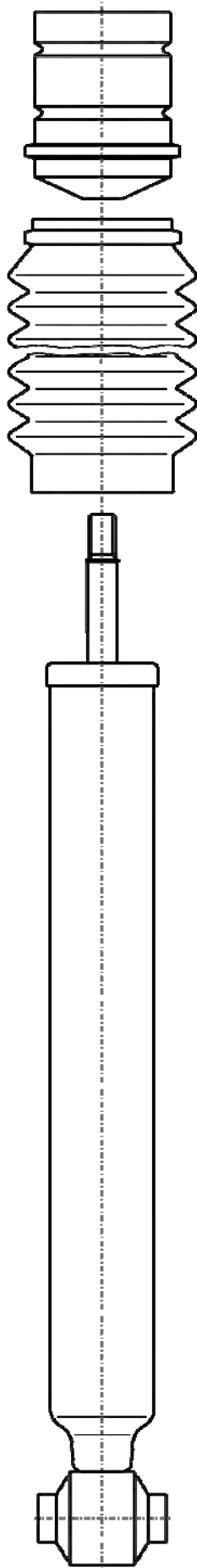

B14

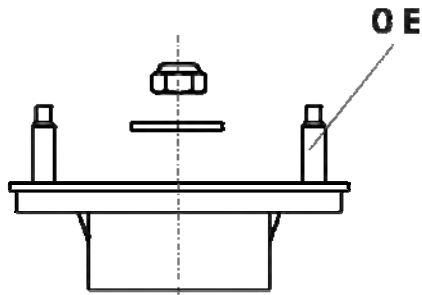

OE

B16 PSS10

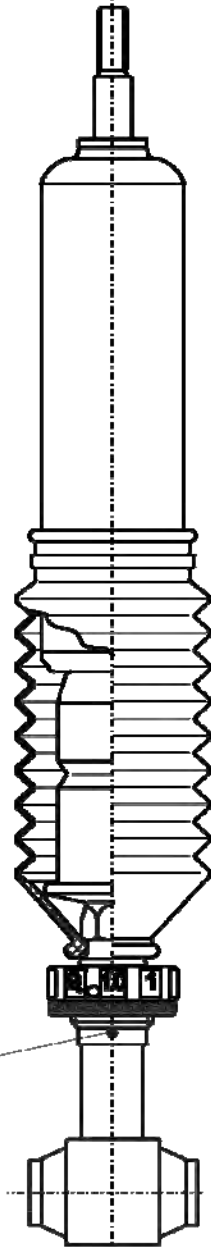

rote Markierung/
red mark

OE = Original Anbauteile
Original Equipment

- mounting instruction for rear axle height adjustment

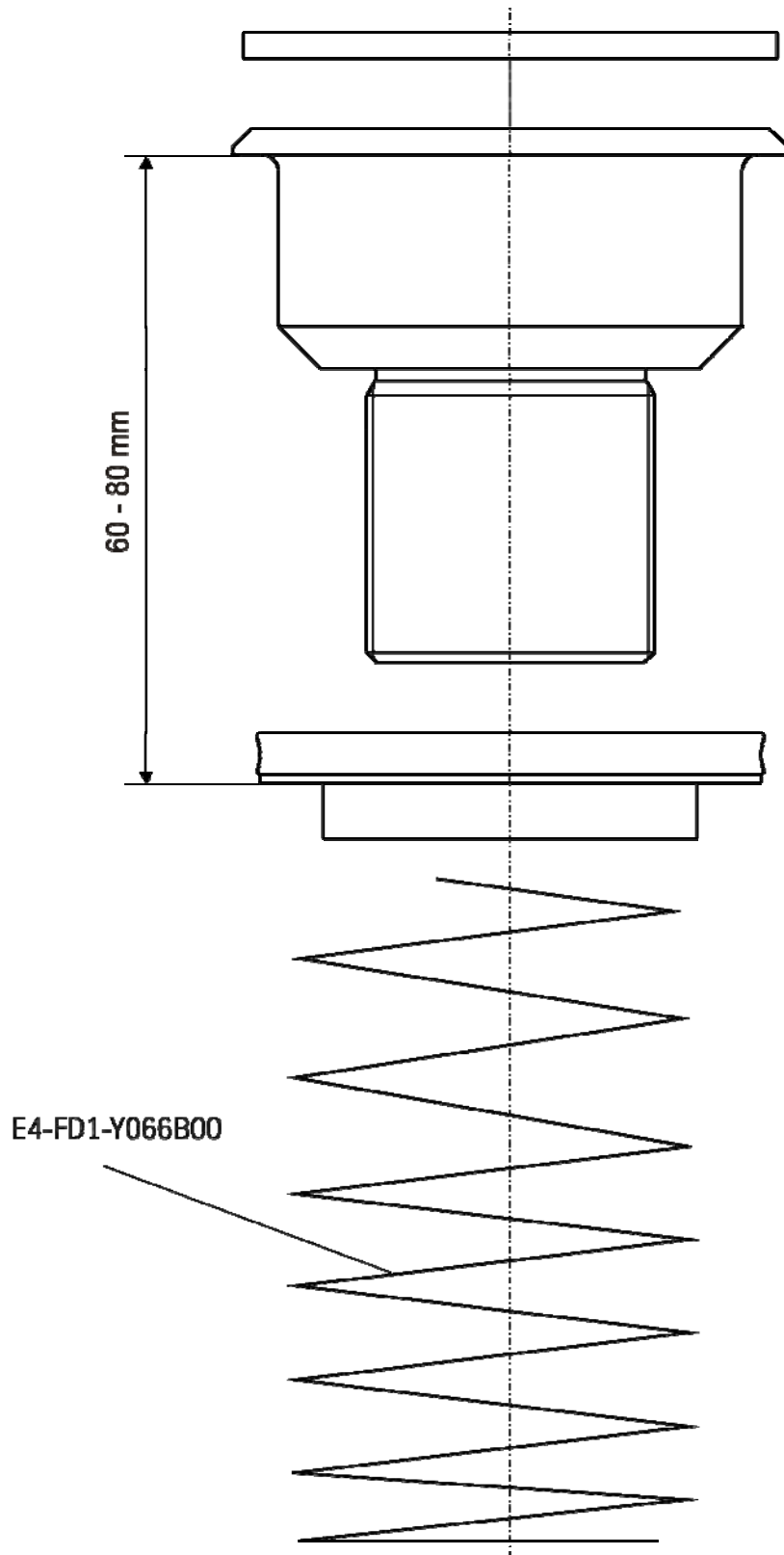

OE = Original Anbauteile
Original Equipment