

position 1 = comfort

position 10 = sport

During the adjustment you will hear a positive „click“ at each position of the adjustment.

Adjusting position must aligned with the red mark on outer tube.

Take care that the adjustment position is the same on both sides of vehicle ( left/ right)

-						list of torques
	M 8	M 10	M 12	M 14	M 16	Thread
	13	25	45	72	110	Torque Nm
	10	19	34	54	83	Torque ft lb

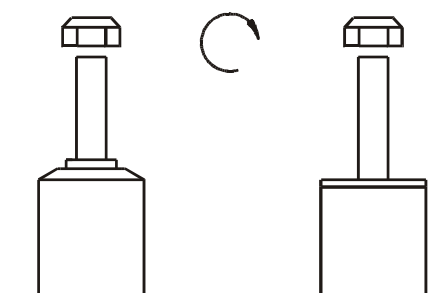

**Do not use an impact tool to loosen or tighten fasteners due to possible damage to the product.**  
**Self- locking nuts must only be used once!**



**Before installation please observe  
the following points:**

- Read all information in this manual carefully.  
    All suspension components are fitted and removed acc. to the manufacturer's specifications for fitting and removing, if not otherwise required in these instructions.
  
- Check that your vehicle type is listed in the certificate as being released for this kit.
  
- Check the product for all components before starting installation!
  
- Check that dimensions and fastening points are comparable between the original and Bilstein shock absorbers.
  
- Directional references (left, right, front, rear) are always with reference to the driving direction.
  
- Remove the negative battery pole.
  
- The test vehicles are left- hand drive cars.

**After installation please observe  
the following points:**

- Set the vehicle height by adjusting spring plates and lock nuts on the new dampers. Only use the supplied spanner wrenches.
  
- All rubber- mounted strut/ damper attachments must not be fully tightened until AFTER the suspension system is loaded (wheels on the ground). Other mounting fasteners (for example brackets) must be securely tightened BEFORE load is placed on the suspension system.
  
- Because the vehicle has been lowered, freedom of movement for all wheel-/ tire- combinations must be checked.
  
- Connect the negative battery pole.
  
- After installing the suspension system, caster and camber must be checked and adjusted according to manufacturer's specifications.
  
- Check and reset load- dependent brake compensator and ABS system according to manufacturer's specifications.
  
- Check and adjust headlight aim.

All diagrams are generalized  
and not to scale!  
brackets, etc. specific to  
strut are not shown!

## Removal shock absorber

Place vehicle on a chassis hoist, lift it and remove wheels.

Vehicles equipped with xenon headlight the sensor for the headlamp levelling controller must removed before.



***The lower control arm must be supported by suitable means!***

Remove bottom mount.

Remove top fixing nuts from support bearing.  
Do not remove centre nuts at this time!

Remove complete shock absorber and clamp it in an appropriate strut vice.

Using a suitable spring compressor, compress suspension spring until tension on support bearing is released.

Release centre nut and remove original mounting parts and coil spring. Please refer to diagram to identify which parts will be replaced with BILSTEIN- supplied components.

## PSS10- 10 step- pin adjustment

The adjustment unit must be deinstall before the shock absorber installation can be completed in reverse sequence as before with BILSTEIN and/ or original mounting parts.

- A-** Gewindeschraube  
Set screw
- B-** Verstellkopf  
Adjusting head
- C-** Kontermutter M12x 1  
lock nut M12x 1
- D-** Anschlagscheibe  
End stop disc
- E-** Mutter M12x1 hoch  
Nut M12x1 high
- F-** Nut M12x1 flat
- G** Set screw
- H** End stop pin
- I** Adjusting screw
- J** Adjusting sheet

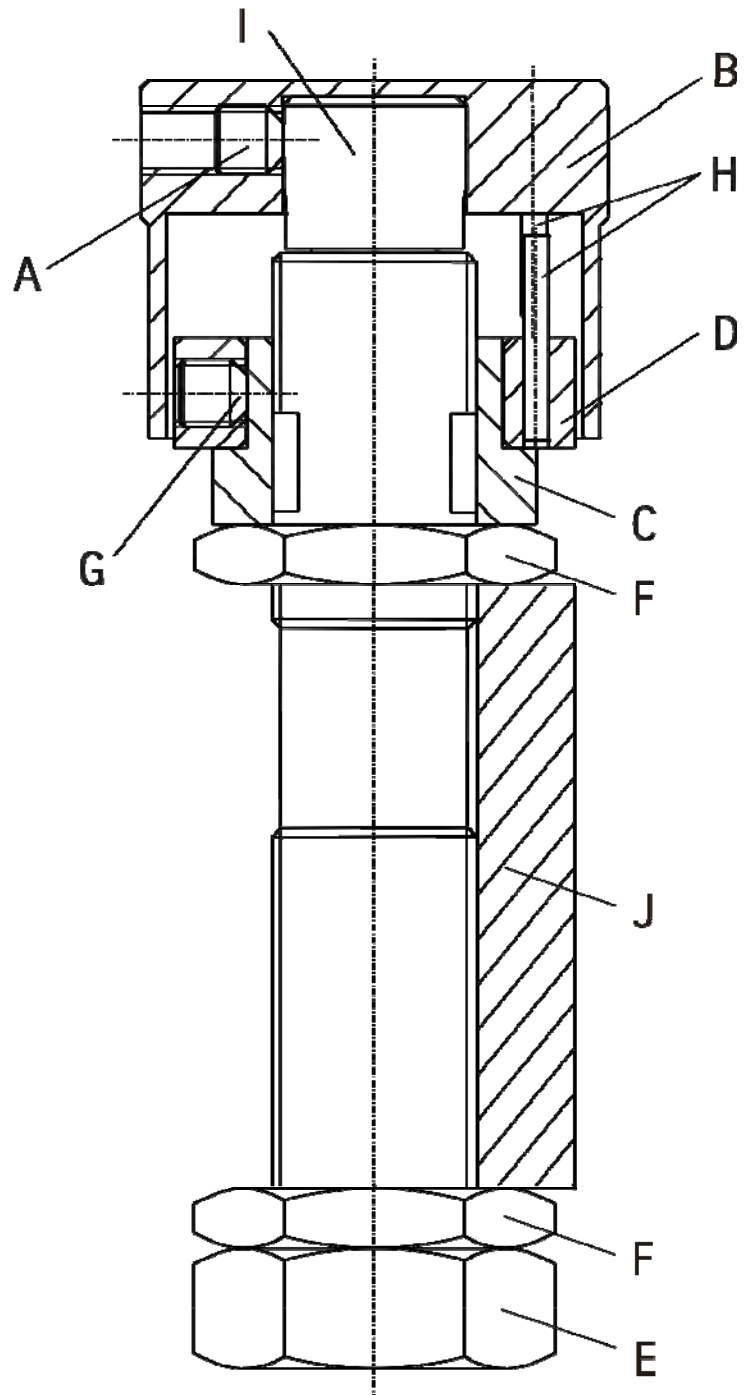

position **1** = **comfort**  
( counter-clockwise direction)  
position **10** = **sport**  
( clockwise direction)

### Instruction for the rear axle

Status of delivery is position **10**.



## Removal Adjustment Unit PSS10

( see sketch on page 5)

To remove the adjusting head ( B )  
the set screw ( A ) must loose.

Loose set screw ( G ) and remove end stop  
disc ( D ). Remove the lock nut ( C ).

Now remove all original mounting parts and  
fit Bilstein and/ or original mounting parts in  
reverse sequence of removal.

## Installing Adjustment Unit PSS10

Tighten nut ( E ) to block and fit lock nut ( F )  
together. Fix the adjusting sheet ( J ) on top of  
lock nut ( F ). Tighten nut ( F ) by hand till con-  
tact the adjusting sheet. Now tighten lock nut  
( C ) to nut ( F ). Remove the adjusting sheet!

Getting an optimal fitting position for the  
adjustment unit turn the end stop disc ( D )  
in a position to a saliently mark at the chas-  
sis you have selected before. Fix the set  
screw ( G ). Pins ( H ) are end stops.

Place the adjusting knob ( A ) flat on the adjust-  
ing screw ( I ) and turn it clockwise to end stop.

Fix the adjusting head ( B ) with set screw ( A ).

The adjusting head should move easily and  
with distinct “clicks” at each adjustment posi-  
tion. If not, disassemble the adjustment unit  
and reassemble acc. To the instruction.

## Installing shock absorber

Assemble BILSTEIN and/ or original  
mounting parts, as well as the new  
BILSTEIN spring on the BILSTEIN  
strut in reverse sequence of removal.



***IMPORTANT! Spring plates must  
not be adjusted outside the  
ranges specified below!***

Fit assembled shock absorber to the vehicle  
in reverse sequence of removal.

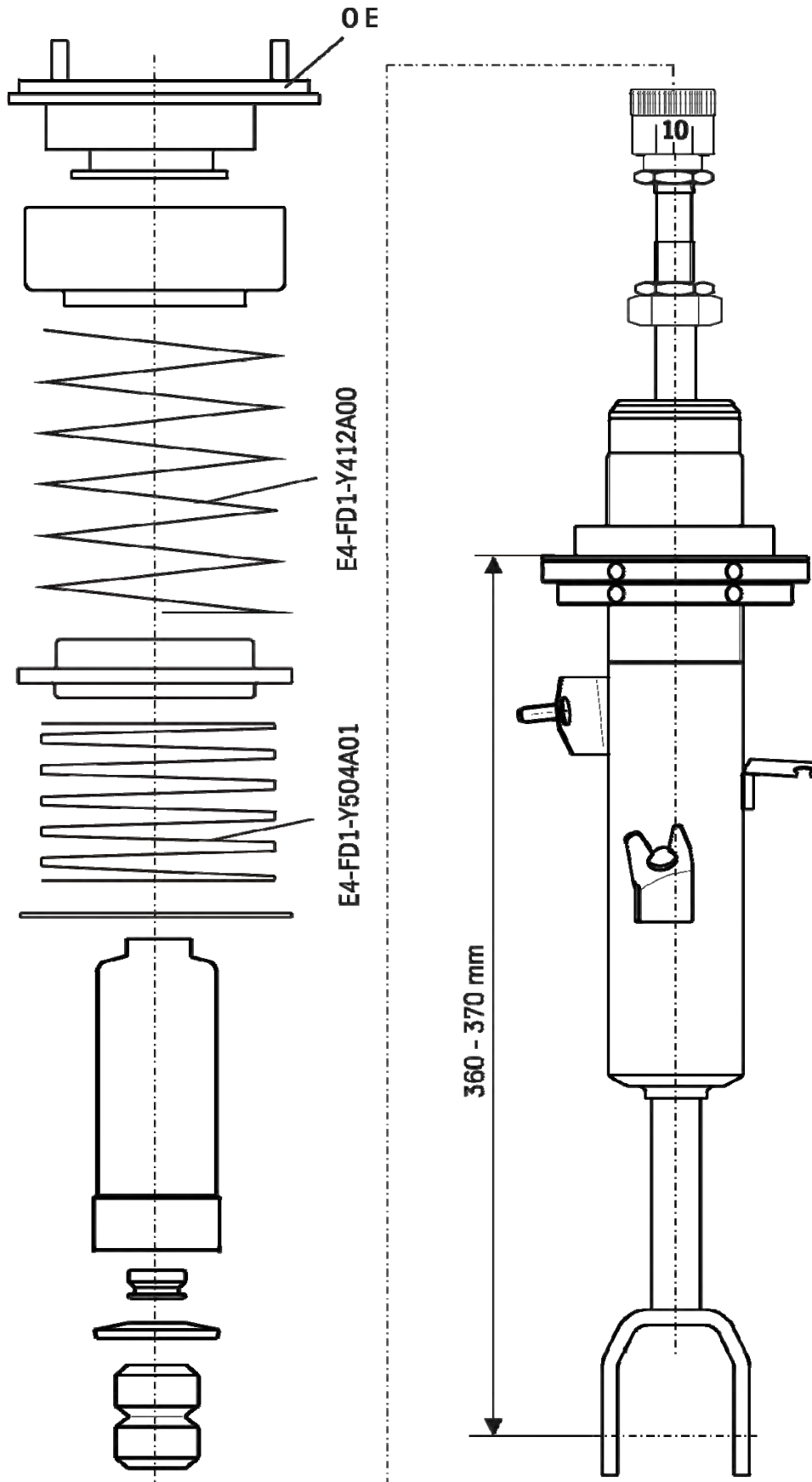

**OE** = Original Anbauteile

BM5-E306

## Removal

Place vehicle on a chassis hoist, lift it and remove wheels.



***The lower control arm must be supported by suitable means!***

Remove top and bottom fixing mount.

Remove shock absorber and original mounting parts.

## Installing

Assemble BILSTEIN and/ or original mounting parts on BILSTEIN shock absorber in reverse sequence of removal.

Fit BILSTEIN shock absorber to the vehicle in reverse sequence of removal.

rote Markierung/  
red mark

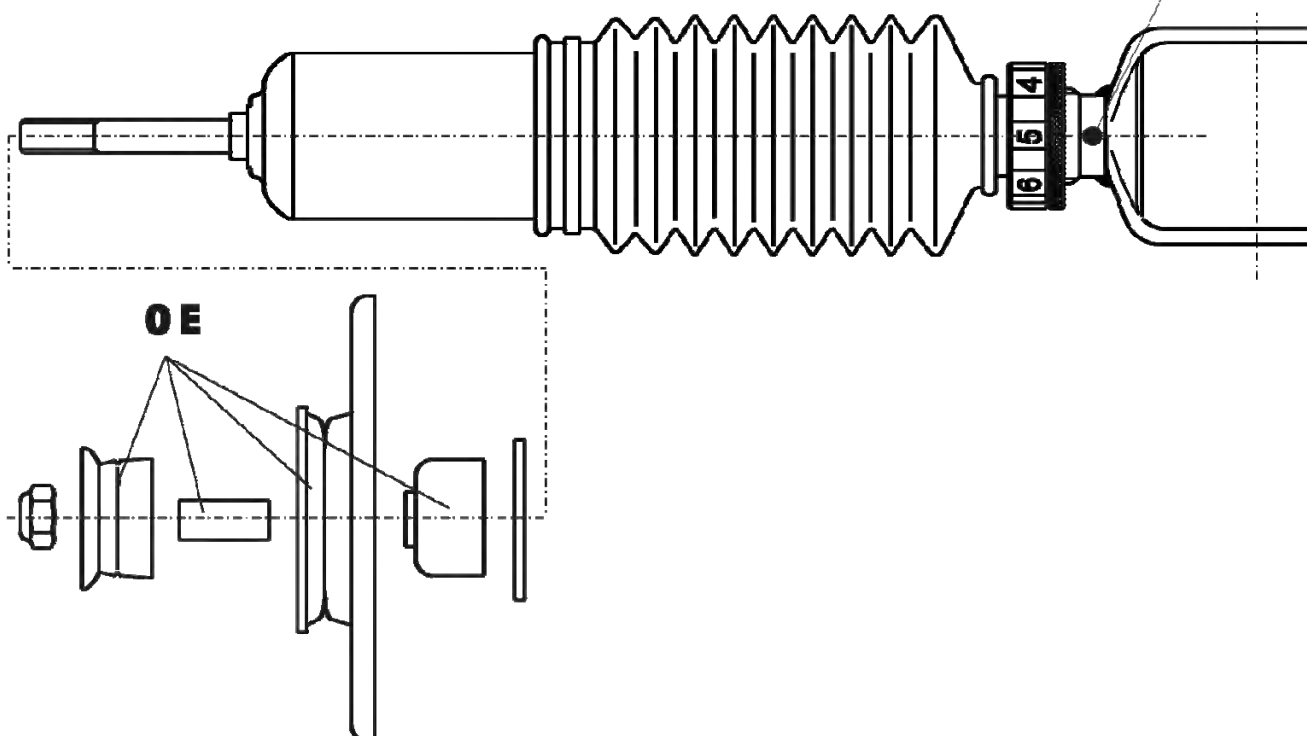

**OE** = Original Anbauteile

- mounting instruction for rear axle height adjustment

For getting the lowest spring seat position  
the lock nut ( A ) is not required.

