



**Before installation please observe
the following points:**

- Read all information in this manual carefully.
All suspension components are fitted and removed acc. to the manufacturer's specifications for fitting and removing, if not otherwise required in these instructions.
- Check that your vehicle type is listed in the certificate as being released for this kit.
- Check the product for all components before starting installation!
- Check that dimensions and fastening points are comparable between the original and Bilstein shock absorbers.
- Remove the negative battery pole.
- Directional references (left, right, front, rear) are always with reference to the driving direction.
- The test vehicles are left- hand drive cars.

**After installation please observe
the following points:**

- Set the vehicle height by adjusting spring plates and lock nuts on the new dampers. Only use the supplied spanner wrenches.
- After installing the suspension system, caster and camber must be checked and adjusted according to manufacturer's specifications.
Check and reset load- dependent brake compensator and ABS system according to manufacturer's specifications.
- Check and adjust headlight aim.
- Because the vehicle has been lowered, freedom of movement for all wheel-/ tire- combinations must be checked.
- All rubber- mounted strut/ damper attachments must not be fully tightened until AFTER the suspension system is loaded (wheels on the ground). Other mounting fasteners (for example brackets) must be securely tightened BEFORE load is placed on the suspension system.
- Connect the negative battery pole.
- All diagrams are generalized and not to scale!
brackets, etc. specific to strut are not shown!

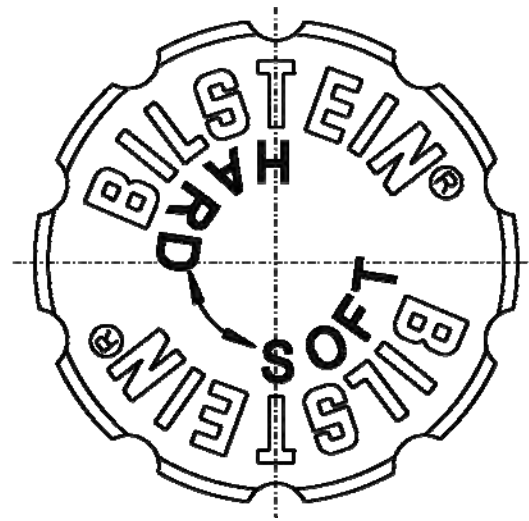
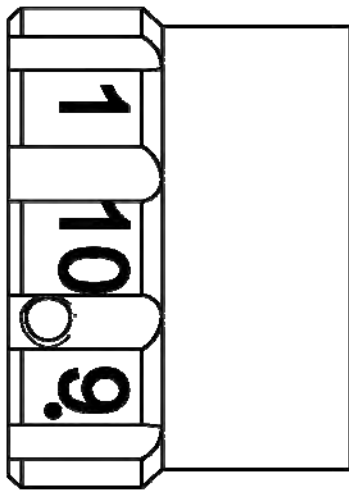

position 1 = **comfort**
position 10 = **sport**

During the adjustment you will hear a positive „click“ at each position of the adjustment.

Status of delivery is position 1.

Instruction for the front axle

The adjusting element of the front struts is located at the bottom edge of the strut.

Adjusting position must aligned with the red mark on outer tube.

Take care that the adjustment position is the same on both sides of vehicle (left/ right)

list of torques

	M8	M 10	M 12	M 14	M 16	Thread
	13	25	45	72	110	Torque Nm
	10	19	34	54	83	Torque ft lb

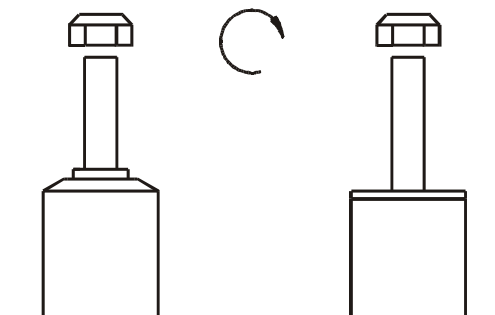

Do not use an impact tool to loosen or tighten fasteners due to possible damage to the product.

Self- locking nuts must only be used once!

Remove

Place vehicle on a chassis hoist, lift it and remove wheels.



The lower control arm must be supported by suitable means!

Remove bottom mount.

Remove top fixing nut from support bearing.
Do not remove centre nut at this time!

Remove complete strut and clamp it in an appropriate strut vice.

Using a suitable spring compressor, compress suspension spring until tension on support bearing is released.

Release centre nut and remove original mounting parts and coil spring. Please refer to diagram to identify which parts will be replaced with BILSTEIN- supplied components.

Install

Assemble BILSTEIN and/ or original mounting parts, as well as the new BILSTEIN spring on the BILSTEIN strut in reverse sequence of removal.



IMPORTANT! Spring plates must not be adjusted outside the ranges specified below!

The correct mounting position of the suspension springs can be determined by the printing on the springs; install them with the print upright.

Do not reuse original- bumper, since BILSTEIN- strut has built in bump stop.

Fit assembled BILSTEIN strut to the vehicle in reverse sequence to removal.

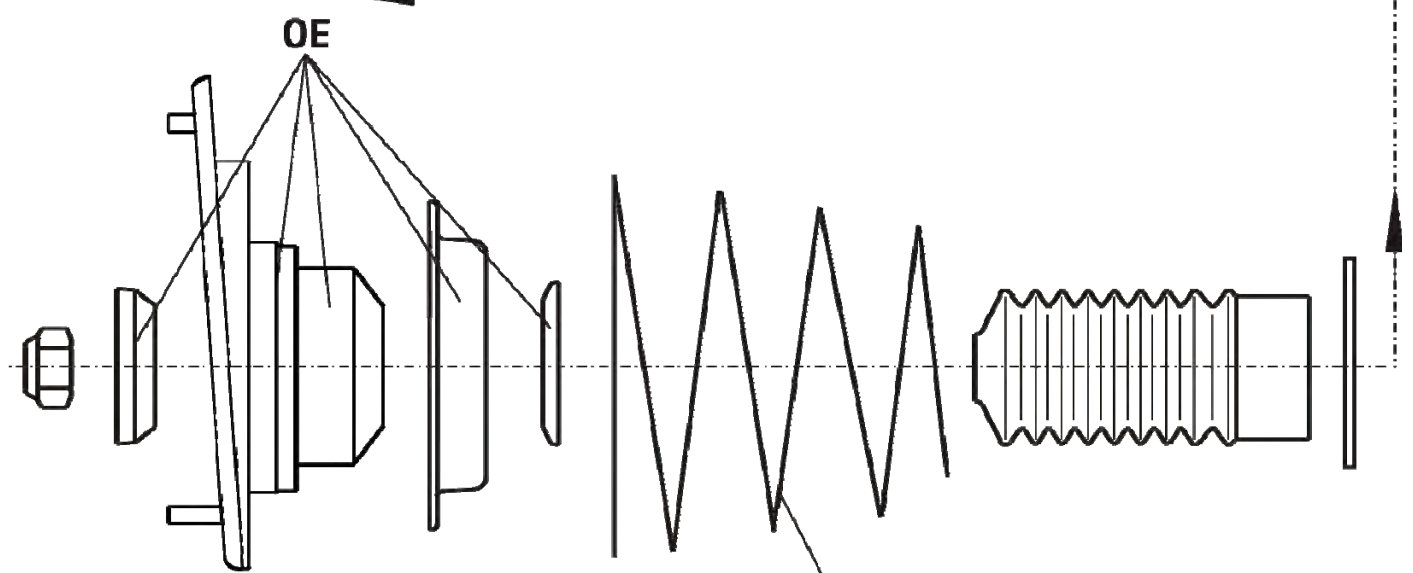
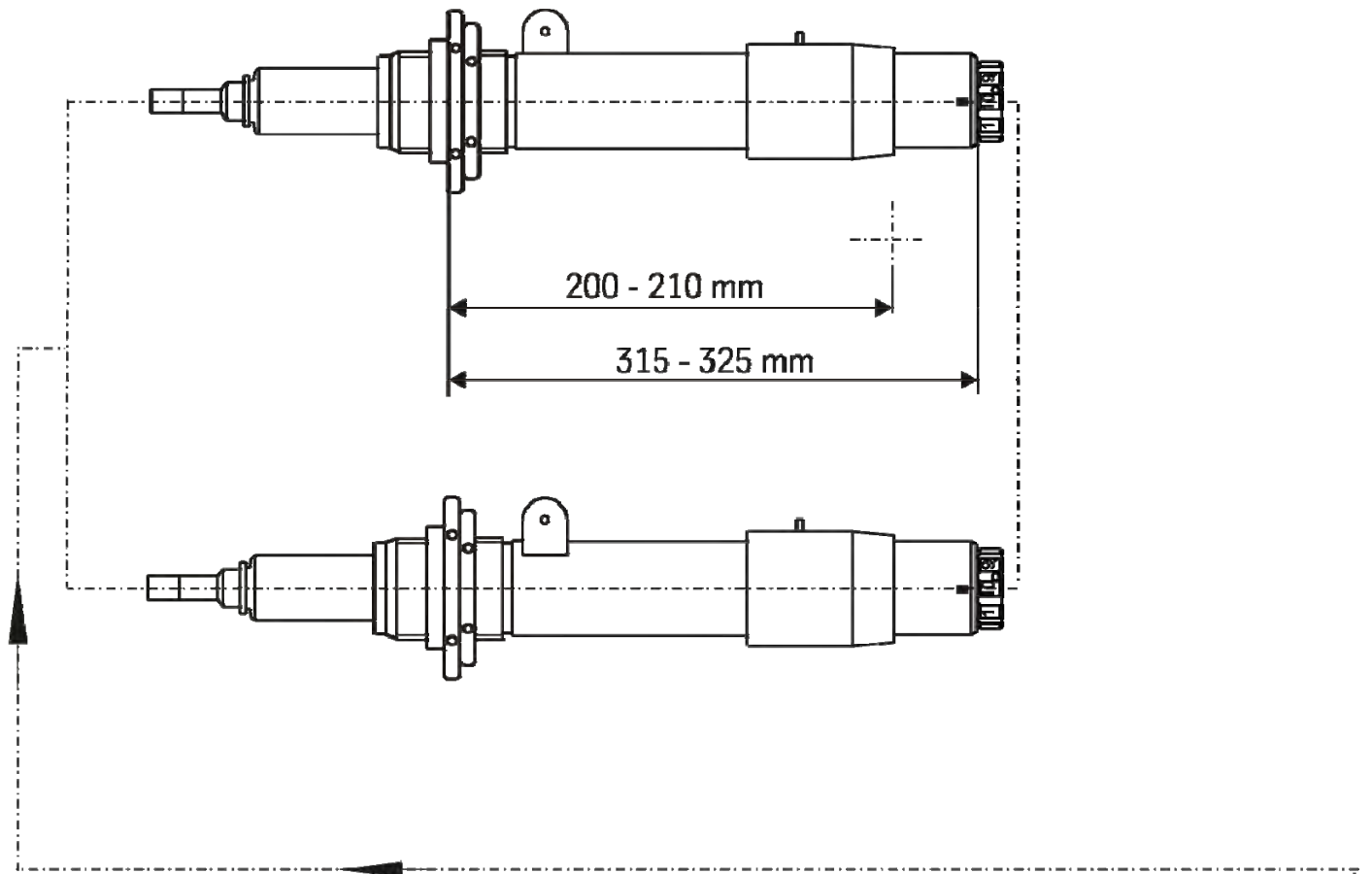

E4-FD1-Y088B00

OE = Original Anbauteile

Removal shock absorber

Place vehicle on a chassis hoist, lift it and remove wheels.



The lower control arm must be supported by suitable means!

Remove bottom mount.

Remove top fixing nuts from support bearing.
Do not remove centre nut at this time!

Remove complete shock absorber and clamp it in an appropriate strut vice.

Compress suspension spring until tension on support bearing is released.

Release centre nut and remove original mounting parts and coil spring. Please refer to diagram to identify which parts will be replaced with BILSTEIN- supplied components.

PSS10- 10 step- pin adjustment

The adjustment unit must be deinstall before the shock absorber installation can be completed in reverse sequence with BILSTEIN and/ or original mounting parts.

Removal Adjustment Unit PSS10

To remove the adjusting head (B) the set screw (A) must loose.

Remove the lock nut (C) together with end stop disc (D).

Now remove all original mounting parts and fit Bilstein and/ or original mounting parts in reverse sequence of removal (see fig. on page 19)

- A-** Gewindeschraube
Set screw
- B-** Verstellkopf
Adjusting head
- C-** Kontermutter M12x 1
lock nut M12x 1
- D-** Anschlagscheibe
End stop disc
- E-** Mutter M12x1
Nut M12x1
- F-** sleeve
- G** Set screw
- H** End stop pin
- I** Adjusting screw

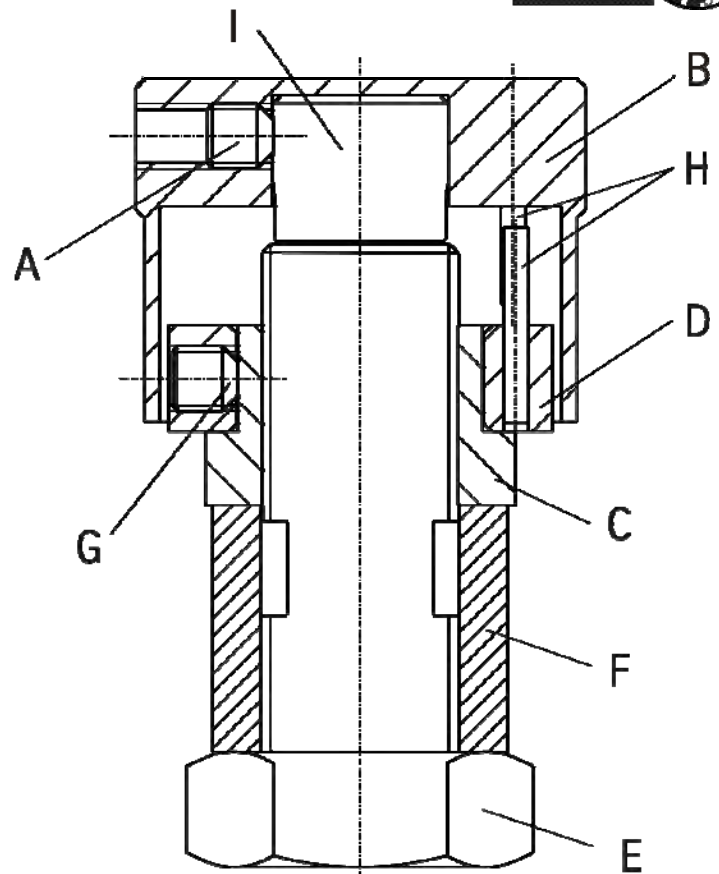

position **1** = **comfort** (CCW direction)
 position **10** = **sport** (CW direction)

Instruction for the rear axle
 Status of delivery is position **10**.



Installing Adjustment Unit PSS10

Tighten (E) to block and fit lock nut (C) together with end stop disc (D).

Getting an optimal fitting position for the adjustment unit you can also loose the set screw (G) and turn the end stop disc (D) in a position to a saliently mark at the chassis you have selected before. Fix the set screw again. Pins (H) are end stops.

Place the adjusting head (B) flat on the adjusting screw (I) and turn it clockwise to end stop.

Fix the adjusting head (B) with set screw (A).

The adjusting head should move easily and with distinct “clicks” at each adjustment position. If not, disassemble the adjustment unit and reassemble acc. To the instruction.

Installing shock absorber

Assemble BILSTEIN and/ or original mounting parts on BILSTEIN shock absorber in reverse sequence of removal.



IMPORTANT! Spring plates must not be adjusted outside the ranges specified below!

Fit assembled shock absorber to the vehicle in reverse sequence of removal.

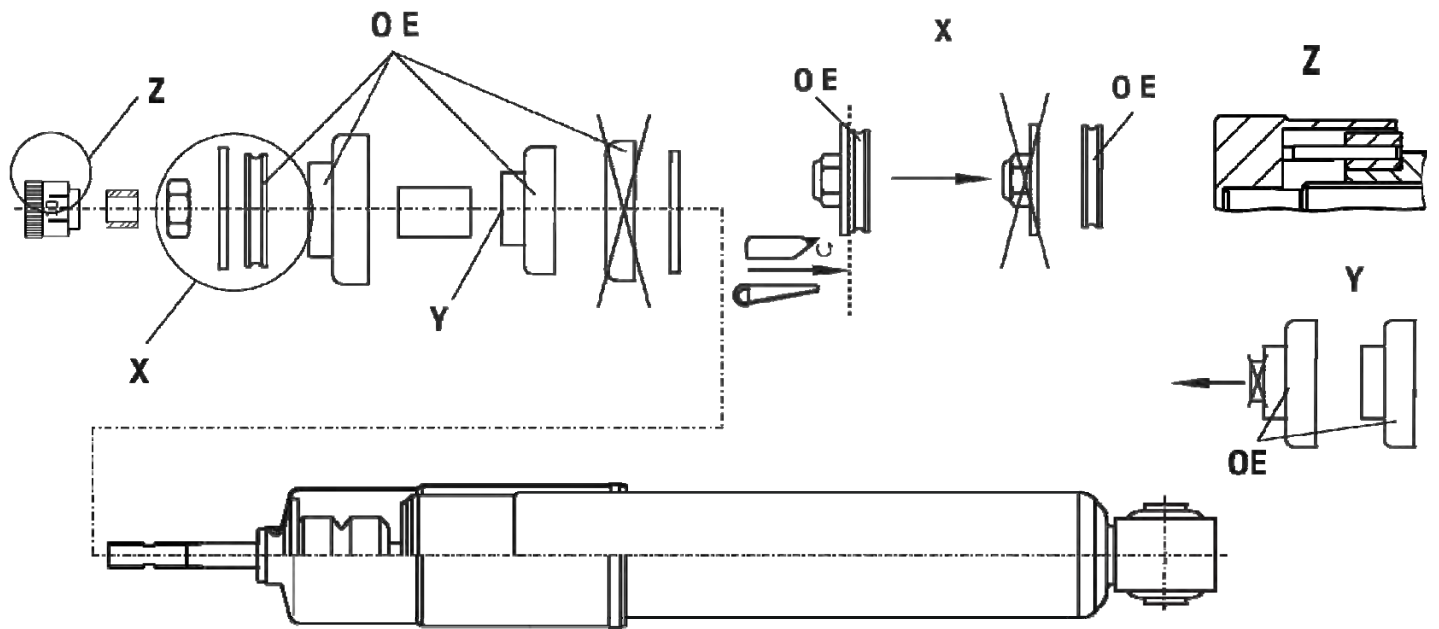

OE = Original Anbauteile

-mounting instruction for rear axle height adjustment

OE= Original Anbauteile

