



**Before installation please observe  
the following points:**

- Read all information in this manual carefully.  
- All suspension components are fitted and removed acc. to the manufacturer's specifications for fitting and removing, if not otherwise required in these instructions.
  
- Check that your vehicle type is listed in the certificate as being released for this kit.
  
- Check the product for all components before starting installation!
  
- Check that dimensions and fastening points are comparable between the original and Bilstein shock absorbers.
  
- Directional references (left, right, front, rear) are always with reference to the driving direction.
  
- Remove the negative battery pole.
  
- The test vehicles are left- hand drive cars.

**After installation please observe  
the following points:**

- Set the vehicle height by adjusting spring plates and lock nuts on the new dampers. Only use the supplied spanner wrenches.
  
- All rubber- mounted strut/ damper attachments must not be fully tightened until AFTER the suspension system is loaded (wheels on the ground). Other mounting fasteners (for example brackets) must be securely tight-ened BEFORE load is placed on the suspension system.
  
- Because the vehicle has been lowered, freedom of movement for all wheel-/ tire- combinations must be checked.
  
- Connect the negative battery pole.
  
- After installing the suspension system, caster and camber must be checked and adjusted according to manufacturer's specifications.
  
- Check and reset load- dependent brake compensator and ABS system according to manufacturer's specifications.
  
- Check and adjust headlight aim.

All diagrams are generalized  
and not to scale!  
brackets, etc. specific to  
strut are not shown!

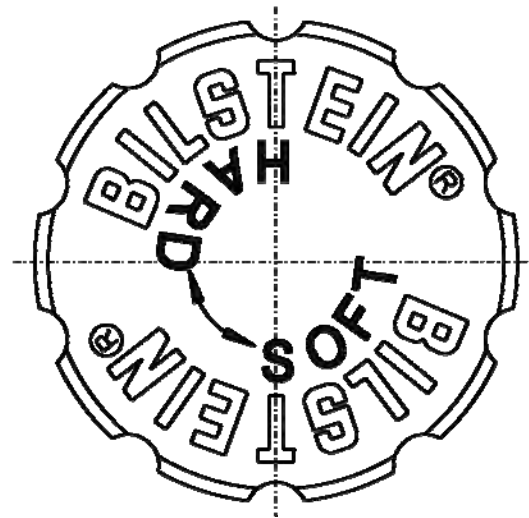
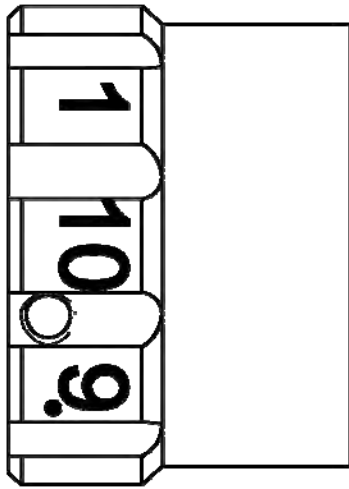

position **1** = **comfort**

position **10** = **sport**

During the adjustment you will hear a positive „click“ at each position of the adjustment.

**Instruction for the front axle**

The adjusting element of the front struts is located at the bottom edge of the strut.

Adjusting position must be aligned with the red mark on outer tube.

Status of delivery is position **1**.

-						list of torques
	M 8	M 10	M 12	M 14	M 16	Thread
	13	25	45	72	110	Torque Nm
	10	19	34	54	83	Torque ft lb

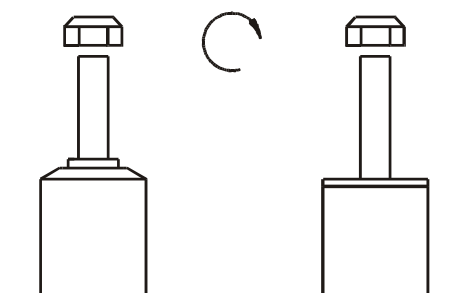

**Do not use an impact tool to loosen or tighten fasteners due to possible damage to the product.**  
**Self- locking nuts must only be used once!**

## Removal

Place vehicle on a chassis hoist, lift it and remove wheels.

Vehicles equipped with xenon headlight the sensor for the headlamp levelling controller must removed before.



***The lower control arm must be supported by suitable means!***

Remove bottom mount.

Remove top fixing nut from support bearing.  
Do not remove centre nut at this time!

Remove complete strut and clamp it in an appropriate strut vice.

Using a suitable spring compressor, compress suspension spring until tension on support bearing is released.

Release centre nut and remove original mounting parts and coil spring. Please refer to diagram to identify which parts will be replaced with BILSTEIN- supplied components.

## Installing

### NOTE:

Remove original stabi link and replace with parts delivered by BILSTEIN. Positioning of the threaded stabi link joint **(G)** is done by loosening the lock nut **(K)** and adjusting to the appropriate angle for left-hand and right-hand assembly situation **(see fig. on page 18/ 19)**.

Do not reuse original- bumper and dust cover, since BILSTEIN- strut has built in bump stop.

Assemble BILSTEIN and/ or original mounting parts, as well as the new BILSTEIN spring on the BILSTEIN strut in reverse sequence of removal.



***IMPORTANT! Spring plates must not be adjusted outside the ranges specified below!***

The correct mounting position of the suspension springs can be determined by the printing on the springs; install them with the print upright.

Fit assembled BILSTEIN strut to the vehicle in reverse sequence to removal.

**OE** = Original Anbauteile

**B** = BILSTEIN Lieferumfang

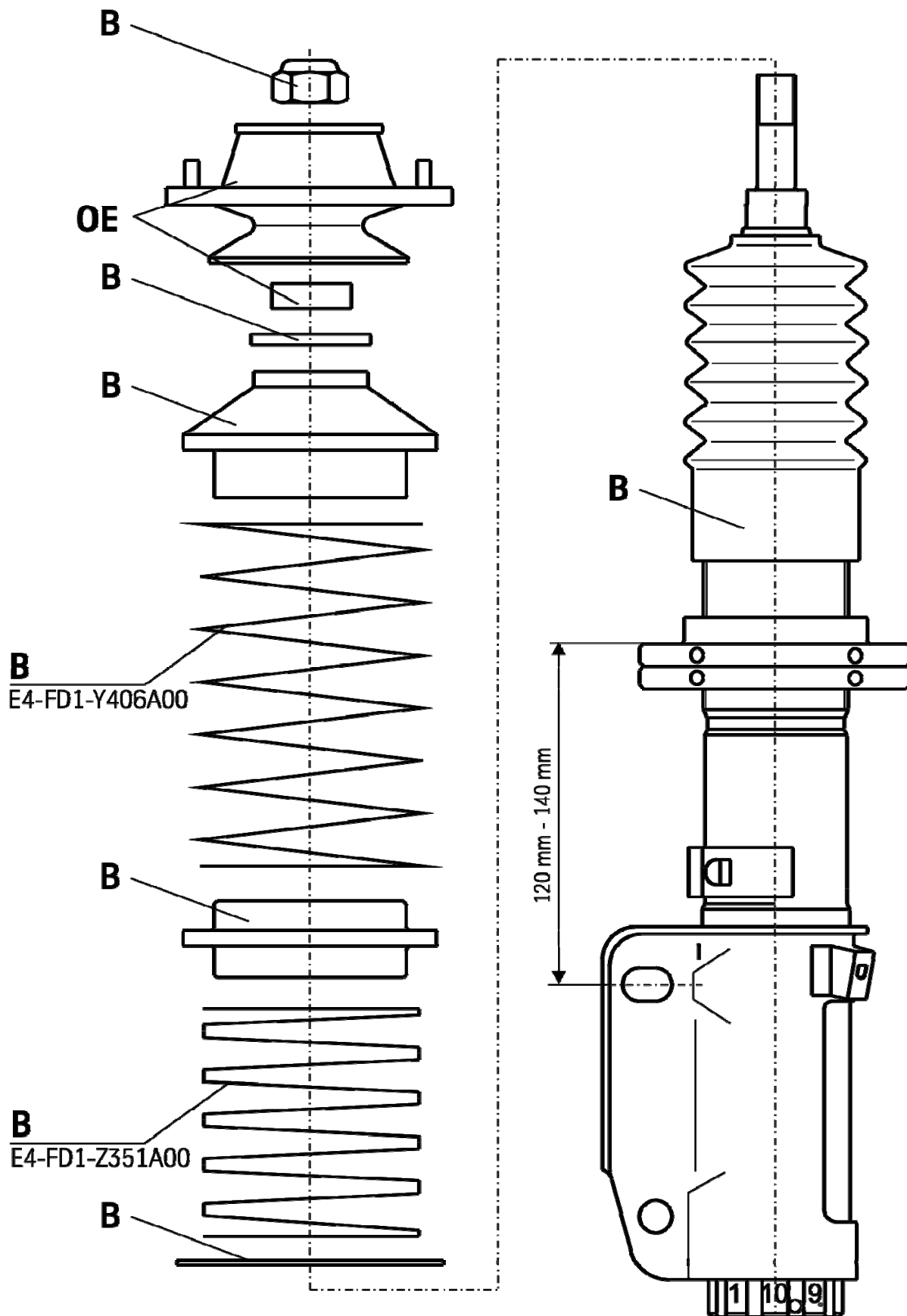

**OE** = Original Anbauteile

**B** = BILSTEIN Lieferumfang

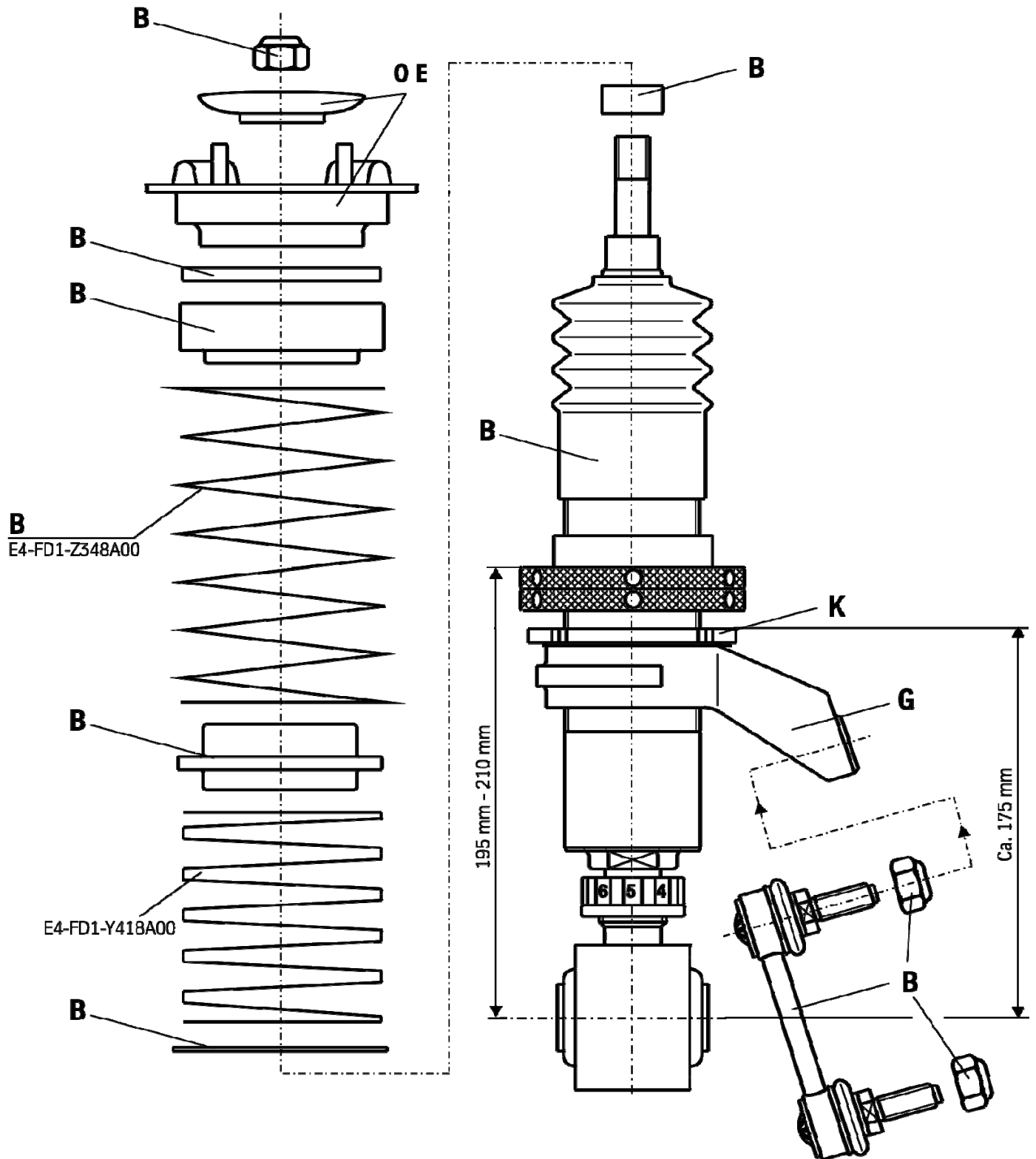

Gelenkbockposition  
left

position of threaded stabi link joint  
right

