



**Before installation please observe the following points:**

- Read all information in this manual carefully.
- All suspension components are fitted and removed acc. to the manufacturer's specifications for fitting and removing, if not otherwise required in these instructions.
- Check that your vehicle type is listed in the certificate as being released for this kit.
- Check the product for all components before starting installation!
- Check that dimensions and fastening points are comparable between the original and Bilstein shock absorbers.
- Remove the negative battery pole.
- Directional references (left, right, front, rear) are always with reference to the driving direction.
- The test vehicles are left- hand drive cars.

**After installation, please observe the following points:**

- Set the vehicle height by adjusting spring plates and lock nuts on the new dampers. Only use the supplied spanner wrenches.
- All rubber- mounted strut/ damper attachments must not be fully tightened until AFTER the suspension system is loaded (wheels on the ground). Other mounting fasteners (for example brackets) must be securely tightened BEFORE load is placed on the suspension system.
- Because the vehicle has been lowered, freedom of movement for all wheel-/ tire- combinations must be checked.
- Connect the negative battery pole.
- After installing the suspension system, caster and camber must be checked and adjusted according to manufacturer's specifications.
- Check and reset load- dependent brake compensator and ABS system according to manufacturer's specifications.
- Check and adjust headlight aim.

All diagrams are generalized and not to scale!  
Brackets, etc. specific to strut are not shown!



- **list of torques**

	M8	M 10	M 12	M 14	M 16	Thread
	13	25	45	72	110	Torque Nm
	10	19	34	54	83	Torque ft lb

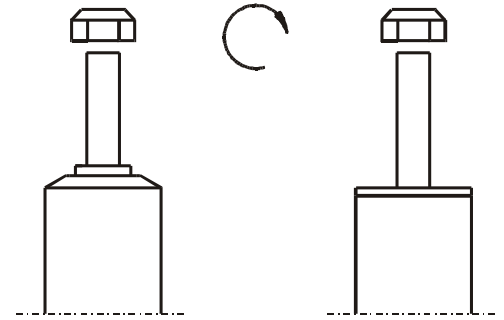

**Do not use an impact tool to loosen or tighten fasteners due to possible damage to the product.**  
**Self- locking nuts must only be used once!**

**instruction for force adjustment**

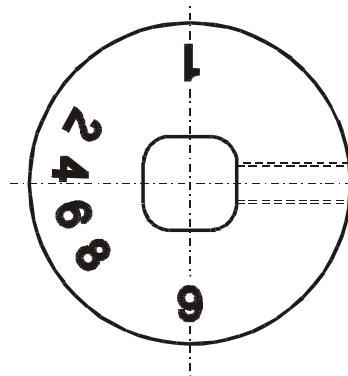

position **9** = **comfort** ( clockwise direction)  
 position **1** = **sport** ( counter- clockwise direction)

During the adjustment you will hear a positive „click“ at each position of the adjustment.

## Removal

Place vehicle on a chassis hoist, lift it and remove wheels.



***The lower control arm must be supported by suitable means!***

Remove bottom mount.

Remove top fixing nuts from support bearing.  
Do not remove centre nut at this time!

Remove complete strut and clamp it in an appropriate strut vice.

Using a suitable spring compressor, compress suspension spring until tension on support bearing is released.

Release centre nut and remove original mounting parts and coil spring. Please refer to diagram to identify which parts will be replaced with BILSTEIN- supplied components.

## Install

Assemble BILSTEIN and/ or original mounting parts, as well as the new BILSTEIN spring on the BILSTEIN strut in reverse sequence of removal.



***IMPORTANT! Spring plates must not be adjusted outside the ranges specified below!***

Delivered bush with inner  $\varnothing$  10,4 mm must be used when original stabilizer holder has inner  $\varnothing$  10,4 mm.

The correct mounting position of the suspension springs can be determined by the printing on the springs; install them with the print upright.

Do not reuse original- bumper, since BILSTEIN- strut has built in bump stop.

Fit assembled BILSTEIN strut to the vehicle in reverse sequence of removal.

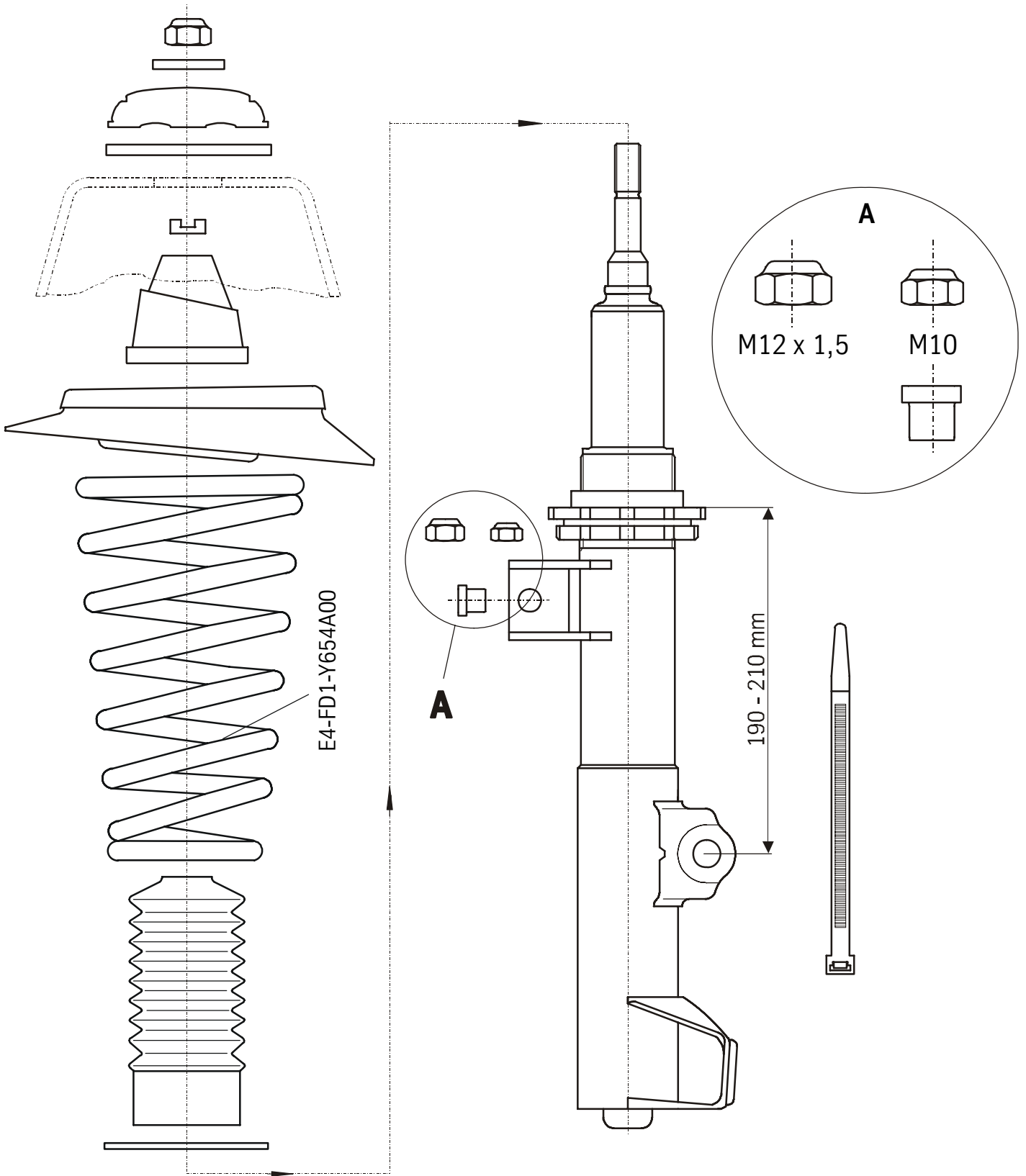

**mounting instruction for rear axle**

### Remove

Place vehicle on a chassis hoist, lift it and remove wheels.

***The lower control arm must be supported by suitable means!***

Remove top and bottom fixing mount.

Remove original shock absorber.



### Install

Fit BILSTEIN mounting parts on BILSTEIN shock absorber according to the sketch below.

Fit BILSTEIN shock absorber to the vehicle in reverse sequence of removal.

**B14**

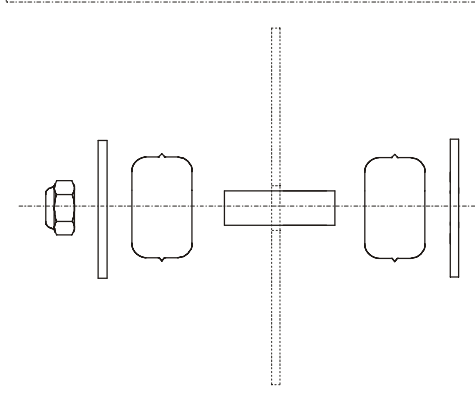
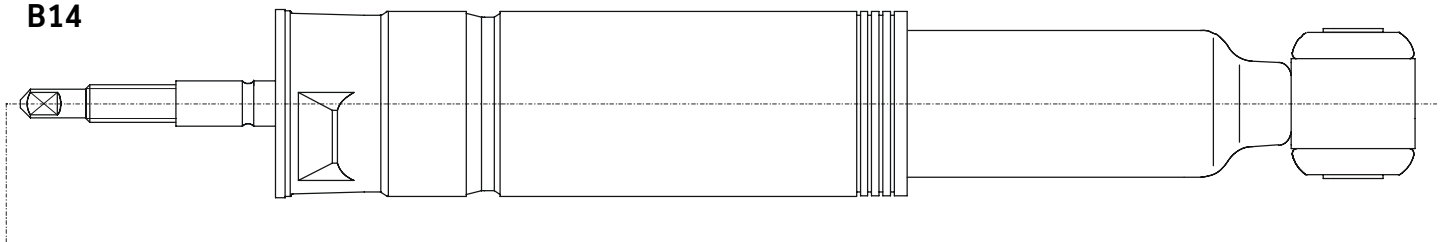

**B16**

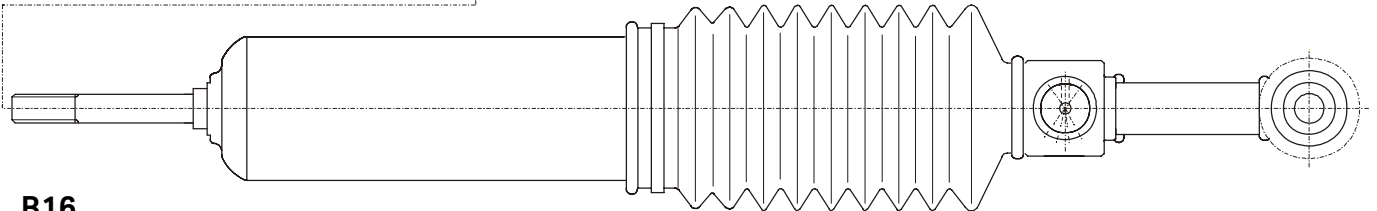

Replace original spring pad by  
Bilstein part.

